

**DISPLAY Elektronik GmbH**

# DATA SHEET

**LCD MODULE**

**DEM 1024600M1 VMH-PW-N  
(C1-TOUCH)**

*Product Specification*

*Version: 2*

**21.12.2020**

# GENERAL SPECIFICATION

---

MODULE NO. :

DEM 1024600M1 VMH-PW-N  
(C1-TOUCH)

CUSTOMER

VERSION NO.	CHANGE DESCRIPTION	DATE
0	ORIGINAL VERSION	13.05.2020
1	CHANGE THE DRAWINGS	19.06.2020
2	CHANGE THE DRAWINGS	21.12.2020

PREPARED BY: YK

DATE: 21.12.2020

APPROVEDBY: MHO

DATE: 21.12.2020

**CONTENTS**

**1. GENERAL SPECIFICATIONS ..... 2**

**2. EXTERNAL DIMENSIONS ..... 4**

**3. BLOCK DIAGRAM ..... 6**

**4. PIN ASSIGNMENT ..... 7**

**5. OPTICAL CHARACTERISTICS ..... 10**

**6. ABSOLUTE MAXIMUM RATINGS ..... 13**

**7. ELECTRICAL CHARACTERISTICS ..... 13**

**8. RELIABILITY TEST ..... 17**

**9. LCD MODULES HANDLING PRECAUTIONS ..... 18**

**10. OTHERS ..... 18**

**1. GENERAL SPECIFICATIONS**

<b>ITEM</b>	<b>STANDARD VALUE</b>	<b>UNIT</b>
LCD TYPE	TFT/IPS/ NORMALLY BLACK/TRANSMISSIVE	
MODULE SIZE	164.90 x 100.00 x 4.95	mm
ACTIVE AREA	154.21 x 85.92	mm
PIXEL PITCH	0.1506 x 0.1432	
NUMBER OF PIXELS	1024 x 3(RGB) x 600	
DRIVER IC	EK73215 + EK79001H	
INTERFACE TYPE	LVDS	
RECOMMEND VIEWING DIRECTION	ALL	O'CLOCK
GRAY SCALE INVERSION DIRECTION	-	O'CLOCK
COLORS	16.7 MILLION	
BACKLIGHT TYPE	30-DIES WHITE LED	
TOUCH PANEL TYPE	CTP	

**Touch Panel:**

<b>Item</b>	<b>Contents</b>
Type	Capacitive Multi-Touch
Module Size	164.90mm x 100.00mm x 1.45mm
View Area	155.21mm x 86.92mm
Driver IC	FT5426-003
Interface	I2C
Operation Voltage	2.6V~3.6V
ITO Glass Thickness	0.4mm
Operation Humidity	20~90%RH
Storage Humidity	20~90%RH
Resolution	1024 x 600
Input Force	≤10g
Temperature Operation	-20°C to +70°C
Temperature Storage	-30°C to +80°C
Input Method	Finger or Exclusive Pen
Transparency	≥88%
Surface Hardness	>6H
Hitting Life	>35,000,000 Times
Insulation	20M ohm or over(Dc 25V)
ESD(Human Body Model)	2,000 V

2. EXTERNAL DIMENSIONS

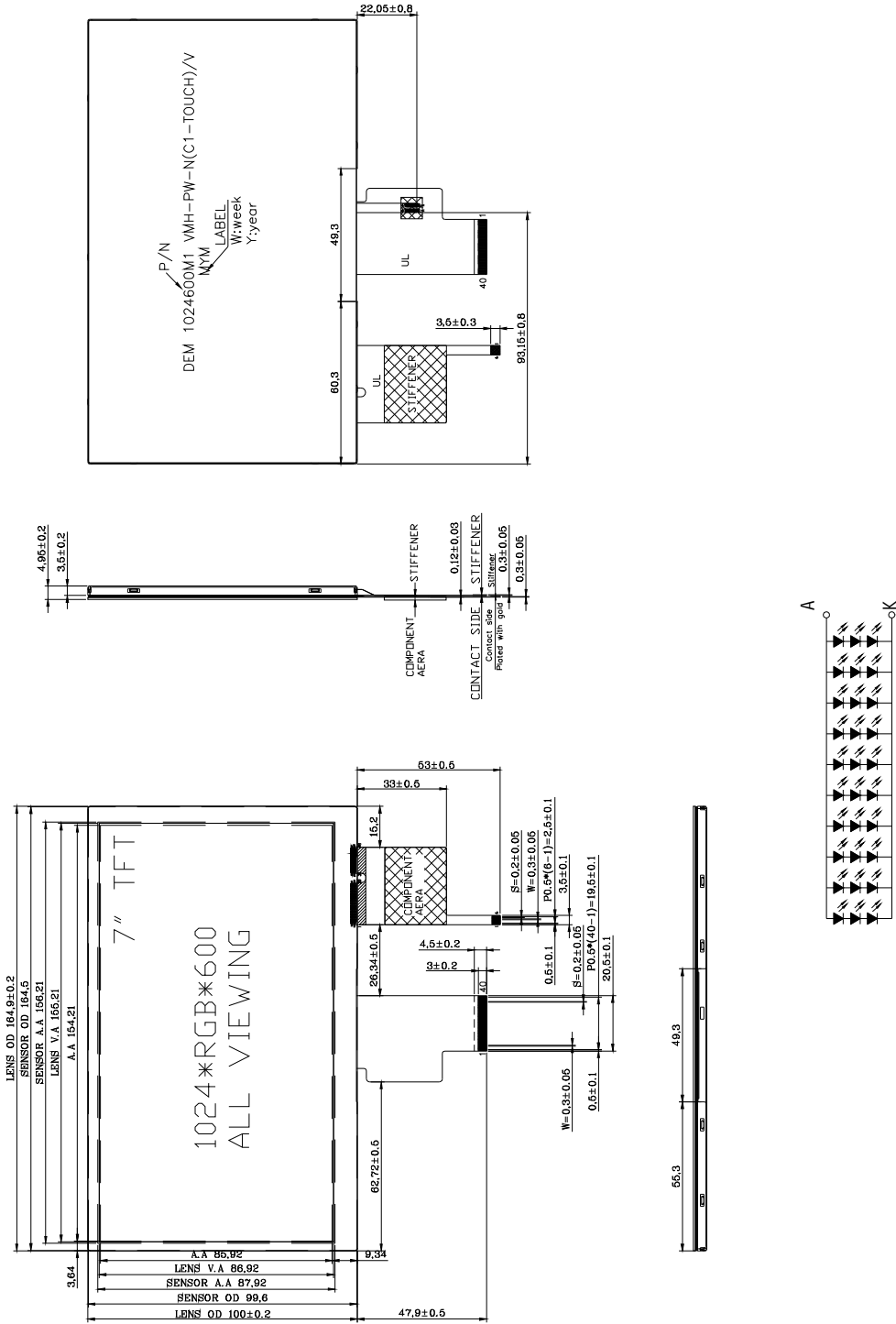

Backlight LED Circuit  
 Circuit Diagram(LED SMT 3\*10=30 PCS), Color: WHITE  
 Vf=8.4-10.5V, If=200mA  
 Brightness 500cd/m<sup>2</sup>(TYP)

Remark:  
 1.Unmarked tolerance is ±0.3  
 2.All materials comply with RoHS

Touch Panel:

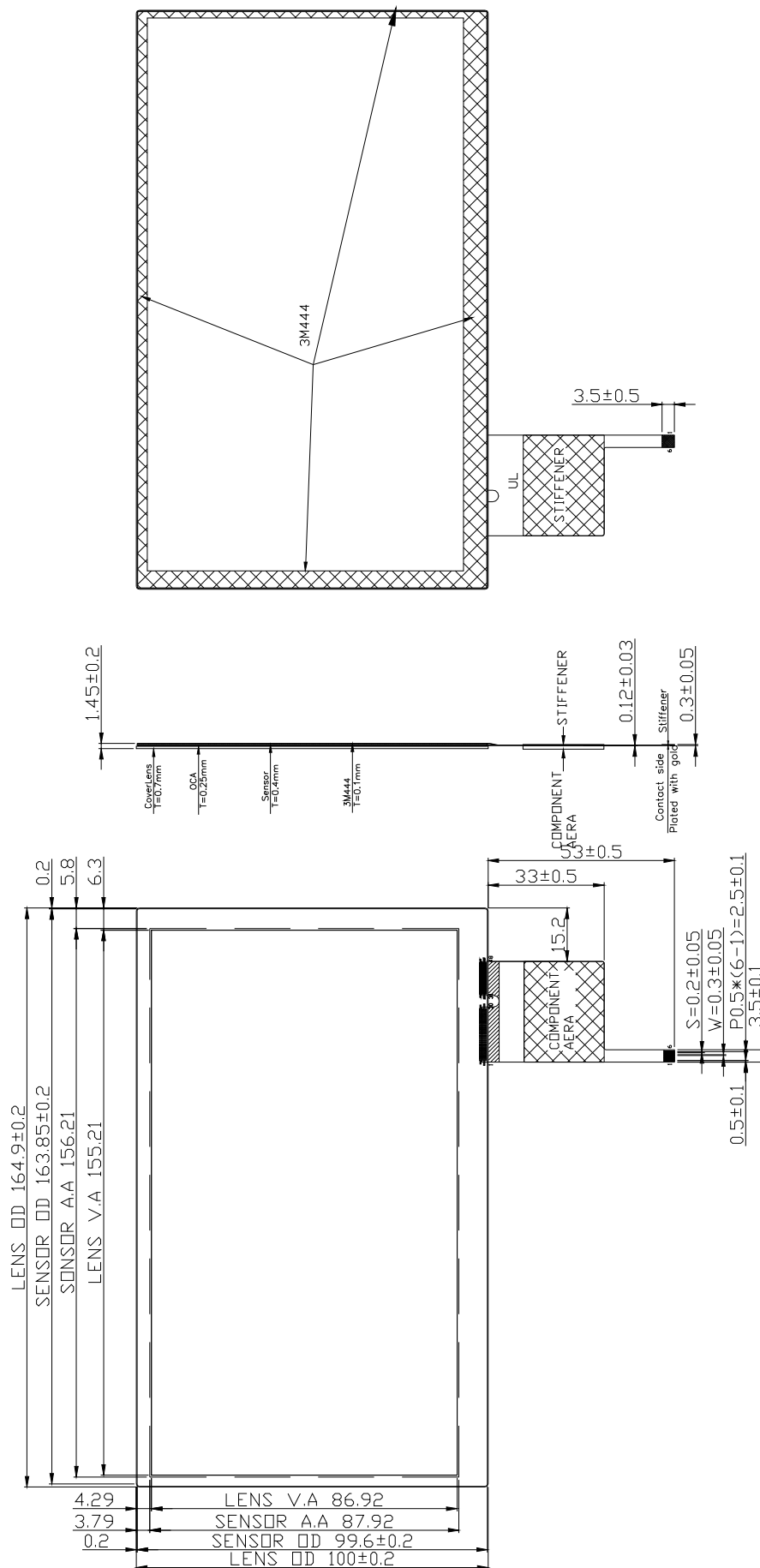

Remarks:

1. Unmarked tolerance is  $\pm 0.3$ , Unmarked radius is R0.5;
2. All materials comply with Rohs;
3.  $\square$  ...:critical dimension.

**3. BLOCK DIAGRAM**

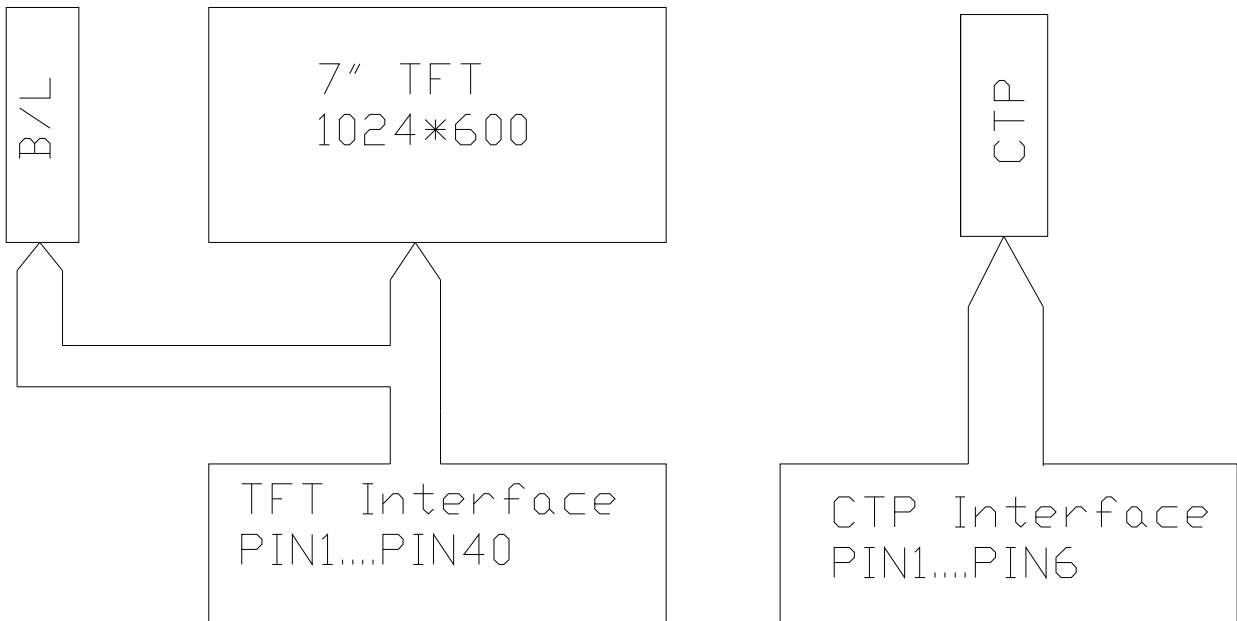



**4. PIN ASSIGNMENT**

<b>PIN NO.</b>	<b>SYMBOL</b>	<b>DESCRIPTION</b>
1	VCOM	Common Voltage
2	VDD	Power Supply
3	VDD	Power Supply
4	NC	Not Connection
5	RESET	Reset Pin
6	STBYB	Standby mode, normally pulled high. STBYB = "1", normal operation STBYB = "0", timing controller, source driver will turn off, all output are High-Z
7	GND	Power Ground
8	RXIN0-	Data Lane0 Input
9	RXIN0+	Data Lane0 Input
10	GND	Power ground
11	RXIN1-	Data Lane1 Input
12	RXIN1+	Data Lane1 Input
13	GND	Power Ground
14	RXIN2-	Data Lane2 Input
15	RXIN2+	Data Lane2 Input
16	GND	Power Ground
17	RXCLKIN-	CLK Input
18	RXCLKIN+	CLK Input
19	GND	Power Ground
20	RXIN3-	Data Lane3 Input
21	RXIN3+	Data Lane3 Input
22	GND	Power Ground
23	NC	Not Connection
24	NC	Not Connection
25	GND	Power Ground
26	NC	Not Connection
27	NC	Not Connection
28	SELB	In LVDS interface connected HSD to FPC for Pin Setting SELB="L":8 bit SELB="H":6 bit
29	AVDD	Power for Analog Circuit
30	GND	Power Ground
31	LED-	LED Cathode

32	LED-	LED Cathode
33	L/R	Source Right or Left sequence control. Normally pull high. L/R = "L", shift left: last data = S1←S2←S3.....←S1200 = first data. L/R = "H", shift right: first data = S1→S2→S3.....→S1200 = last data
34	U/D	Gate Up or Down scan control. Normally pull low. UPDN = "L", STV2 output vertical start pulse and UD pin output logical "0" to Gate driver.(Default) UPDN = "H", STV1 output vertical start pulse and UD pin output logical "1" to Gate driver.
35	VGL	Gate OFF Voltage
36	NC	Not Connection
37	NC	Not Connection
38	VGH	Gate ON Voltage
39	LED+	LED Anode
40	LED+	LED Anode

**SELECTION OF SCANNING MODE**

SETTING OF SCAN CONTROL INPUT		SCANNING DIRECTION
U/D	L/R	
GND	DVDD	UP TO DOWN, RIGHT TO LEFT
DVDD	GND	DOWN TO UP, LEFT TO RIGHT
GND	GND	UP TO DOWN, LEFT TO RIGHT
DVDD	DVDD	DOWN TO UP, RIGHT TO LEFT

DEFINITION OF SCANNING DIRECTION REFER TO THE FIGURE AS BELOW:

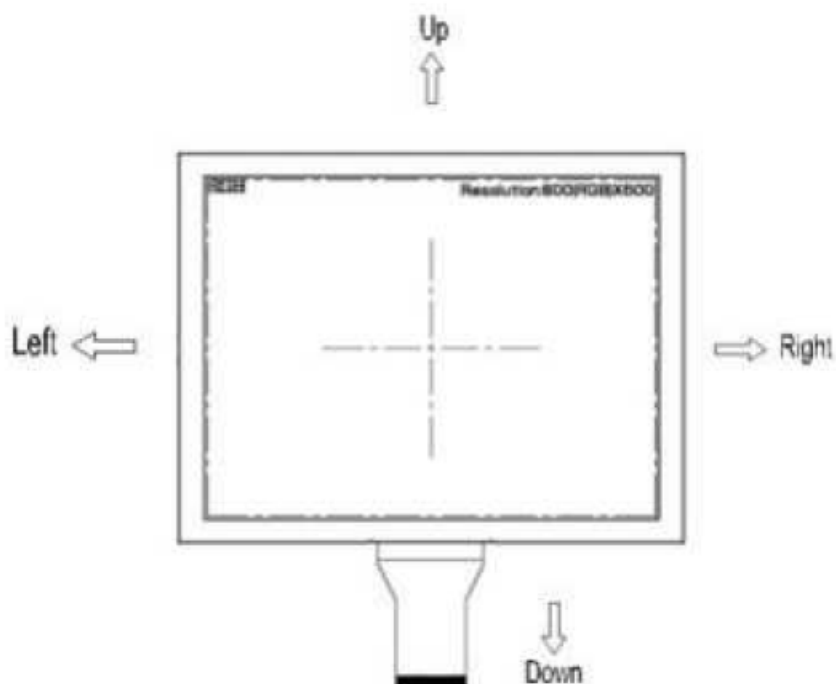

# **DEM 1024600M1 VMH-PW-N(C1-TOUCH)      Product Specification**

---

**Touch Panel:**

Pin No.	Symbol	Description
1	VCC	Positive Power Supply(3.3V)
2	GND	Negative Supply
3	I2C_SCL	I2C Serial Clock Input / Output
4	I2C_SDA	I2C Serial Data Input / Output
5	INT	External Interrupt
6	RST	External Reset, Low is active

**5. OPTICAL CHARACTERISTICS**

ITEM	SYMBOL	CONDITIONS	SPECIFICATIONS			UNIT	NOTE
			MIN	TYP.	MAX		
Luminance	L		320	400	-	Cd/m <sup>2</sup>	
Contrast Ratio	CR	$\theta = 0^\circ$	640	800			
Response Time	Rising	T <sub>R</sub>	25°C	4	8	ms	
	Falling	T <sub>F</sub>		12	24		
CIE COLOUR COORDINATE	RED	XR	VIEWING NORMAL ANGLE				
		YR					
	GREEN	XG					
		YG					
	BLUE	XB					
		YB					
	WHITE	XW					
		YW					
VIEWING ANGLE	Hor.	$\theta_{x+}$	CR ≥ 10	80	85	Degree	
		$\theta_{x-}$		80	85		
	Ver.	$\theta_{y+}$		80	85		
		$\theta_{y-}$		80	85		

Note 1 : Definition of Viewing Angle  $\theta_x$  and  $\theta_y$  :

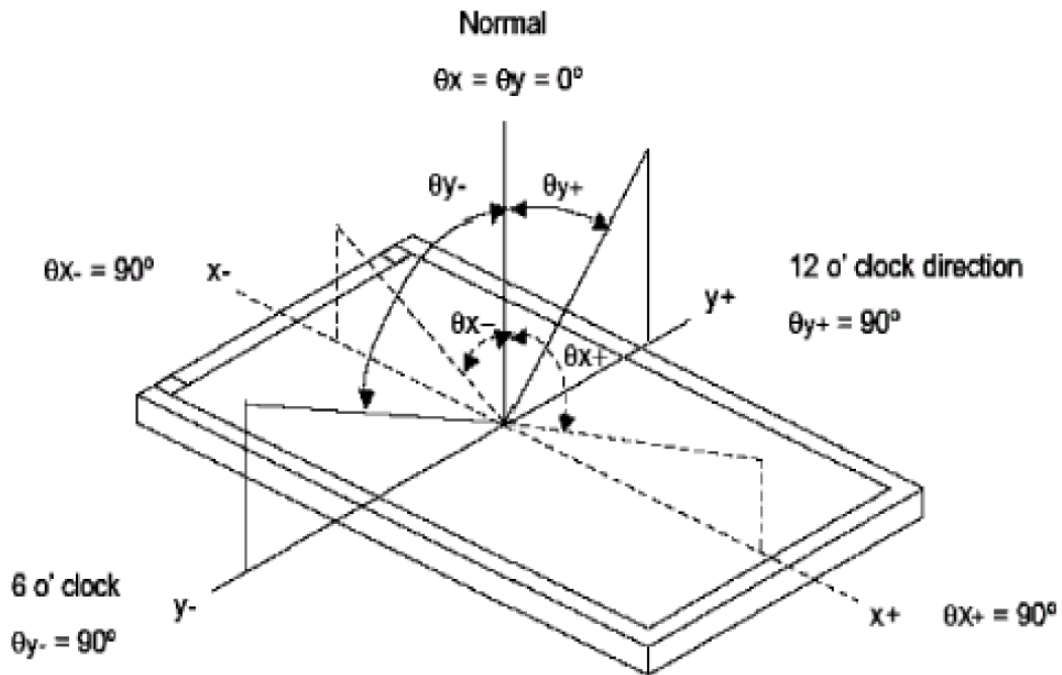

Note 2: Definition of contrast ratio CR:

$$CR = \frac{\text{Brightness of non-selected dots (white)}}{\text{Brightness of selected dots (black)}}$$

Note 3: Definition of response time ( $T_R$ ,  $T_F$ )

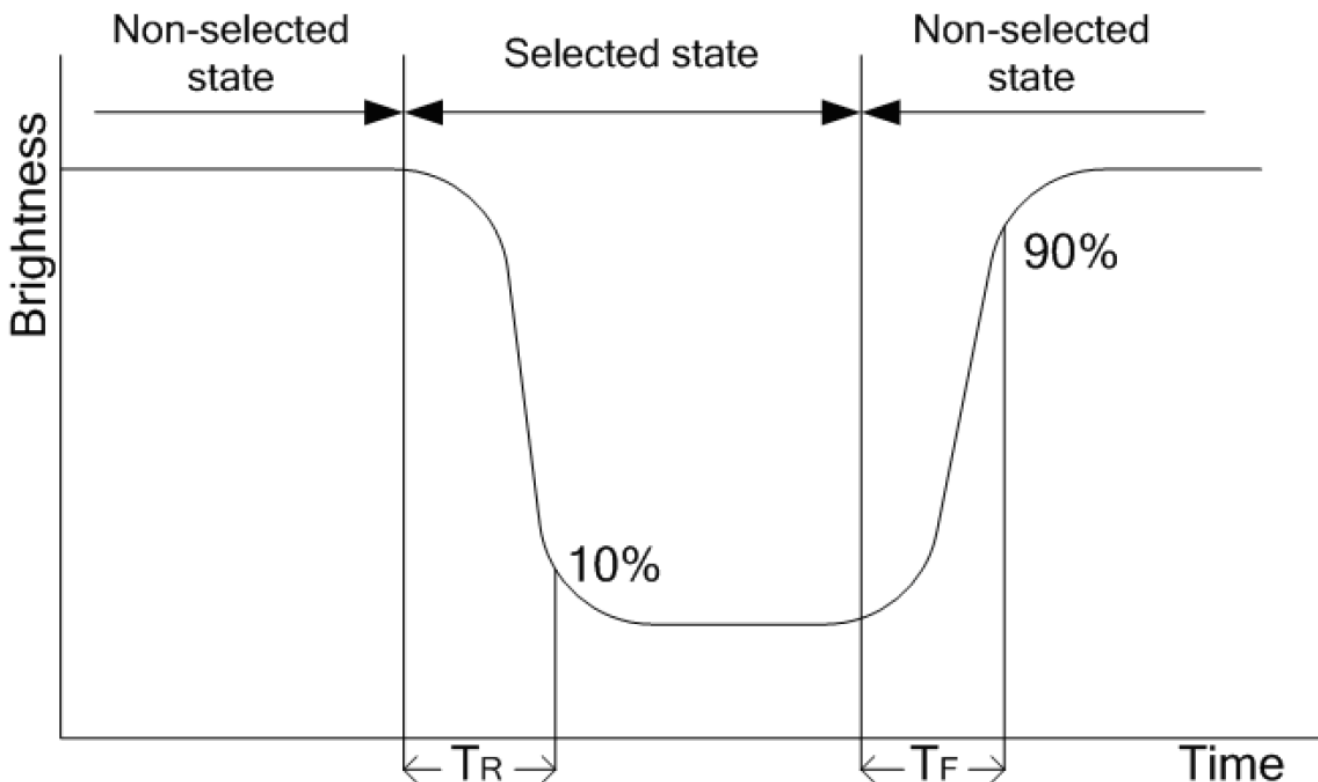

**Note 4: Definition of Luminance**

**① The Brightness Test Equipment Setup**

Field=2° (As measuring “black” image, field=2° is the best testing condition)

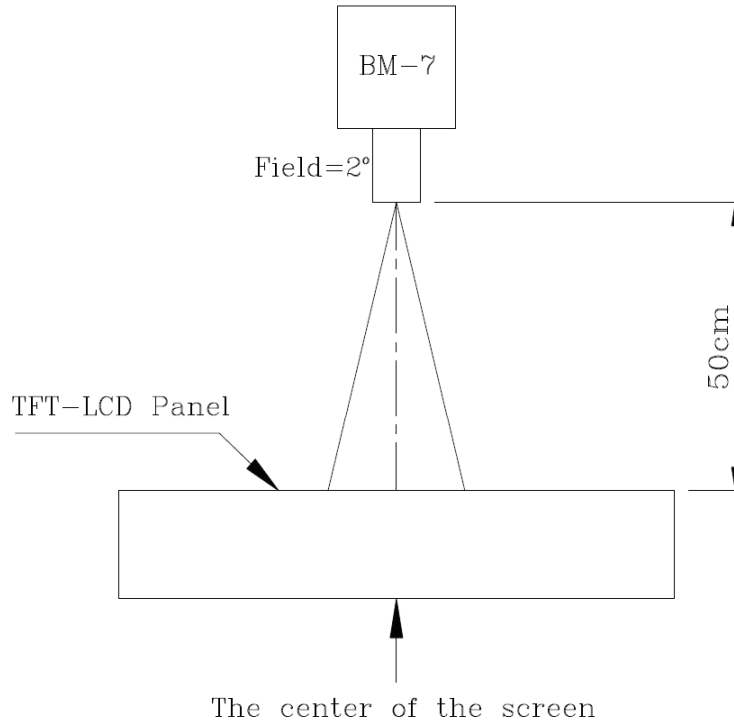

**② The Brightness Test Point Setup**

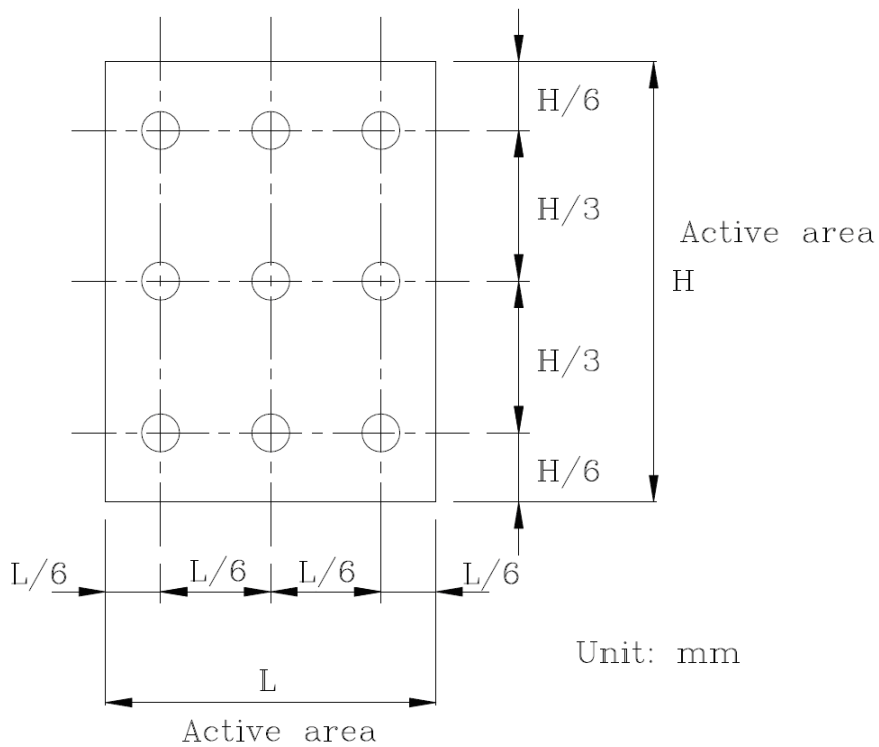

**6. ABSOLUTE MAXIMUM RATINGS**

PARAMETER	SYMBOL	MIN	MAX	UNIT
Power Supply Voltage	VDD	-0.5	5.0	V
Operating Temperature	Top	-20	+70	°C
Storage Temperature	Tst	-30	+80	°C

**7. ELECTRICAL CHARACTERISTICS**

**7.1 BLACKLIGHT DRIVING CONDITIONS**

ITEM	SYMBOL	SPECIFICATIONS			UNIT	REMARK
		MIN	TYP.	MAX		
Supply Voltage	Vf	8.4		10.5	V	
Supply Current	IL		200		mA	
Power Consumption	P	1.68		2.1	W	
LED Lifetime			50,000		H <sub>r</sub>	

**7.2 ELECTRICAL CHARACTERISTICS**

ITEM	SYMBOL	MIN	TYP.	MAX	UNIT
Power Supply	VDD	3.0	3.3	3.6	V
	AVDD	8.9	9.0	9.1	V
	VGH	17	18	19	V
	VGL	-6.5	-6.0	-5.5	V
	VCOM	3.0	3.15	3.3	V
Input Voltage	Vil	GND	-	0.3VDD	V
	Vih	0.7VDD	-	VDD	V

7.3 TIMING CHARACTERISTICS

7.3.1 Vertical input timing

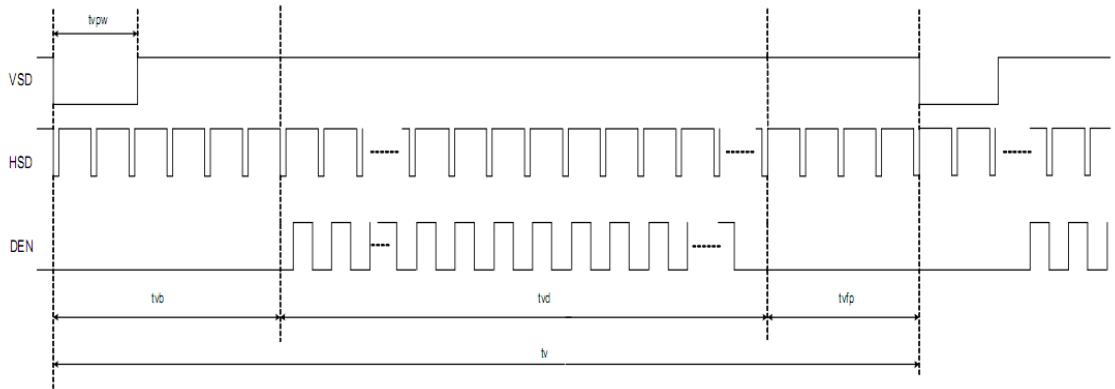

7.3.2 Horizontal input timing

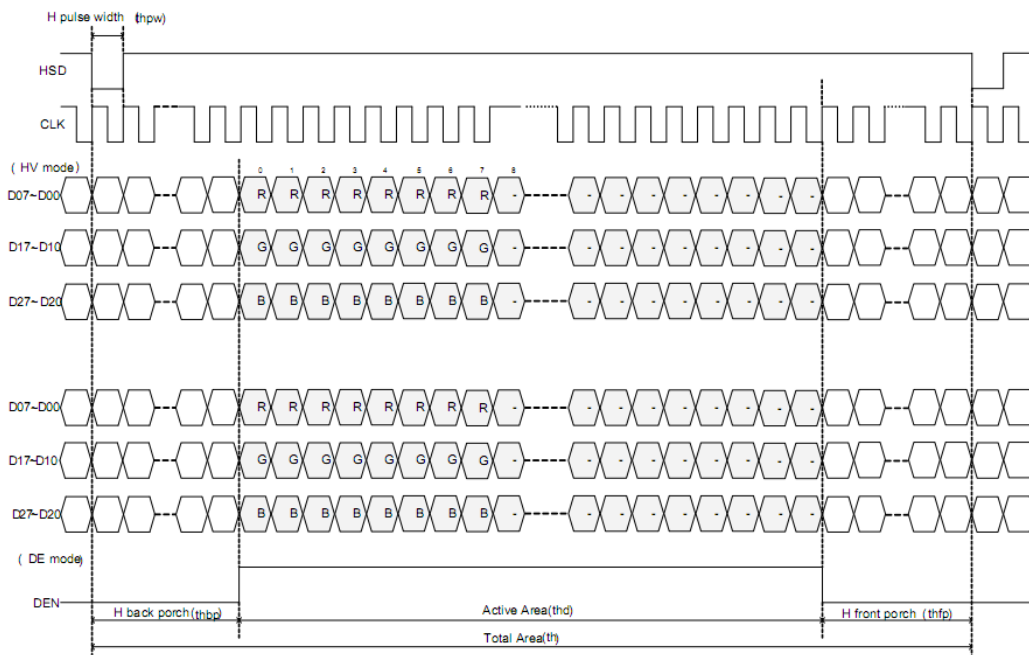



DE mode

DE mode					
Parameter	Symbol	Value			Unit
		Min.	Typ.	Max.	
DCLK frequency @Frame rate=60hz	fclk	40.8	51.2	67.2	Mhz
Horizontal display area	thd	1024			DCLK
HSYNC period time	th	1114	1344	1400	DCLK
HSYNC blanking	thb+thfp	90	320	376	DCLK
Vertical display area	tvd	600			H
VSYNC period time	tv	610	635	800	H
VSYNC blanking	tvb+tvfp	10	35	200	H

HV mode(1)

HV mode					
Horizontal input timing					
Parameter	Symbol	Value			Unit
Horizontal display area	thd	1024			DCLK
DCLK frequency@ Frame rate=60hz	fclk	Min.	Typ.	Max.	Mhz
		44.9	51.2	63	
1 Horizontal Line	th	1200	1344	1400	DCLK
HSYNC pulse width	thpw	Min.	1		
		Typ.	-		
		Max.	140		
HSYNC back porch	thbp	160	160	160	
HSYNC front porch	thfp	16	160	216	

HV mode(2)

Vertical input timing					
Parameter	Symbol	Value			Unit
		Min.	Typ.	Max.	
Vertical display area	tvd	600			H
VSYNC period time	tv	624	635	750	H
VSYNC pulse width	tpw	1	-	20	H
VSYNC back porch	tvb	23	23	23	H
VSYNC front porch	tvfp	1	12	127	H

DATE INPUT FORMAT

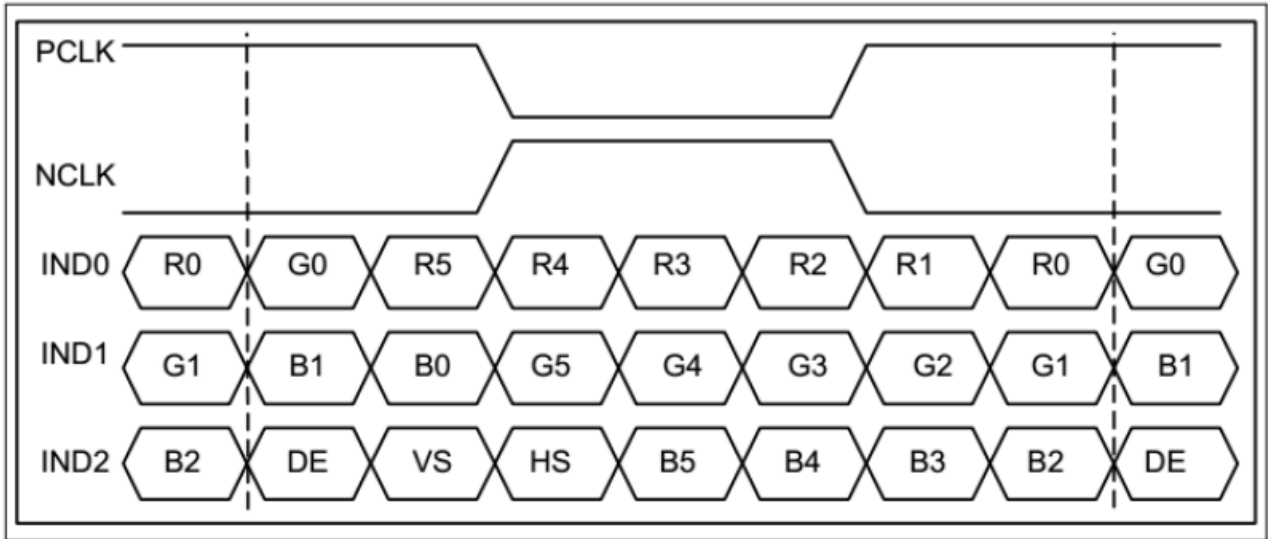

6-bit LVDS Input Timing chart

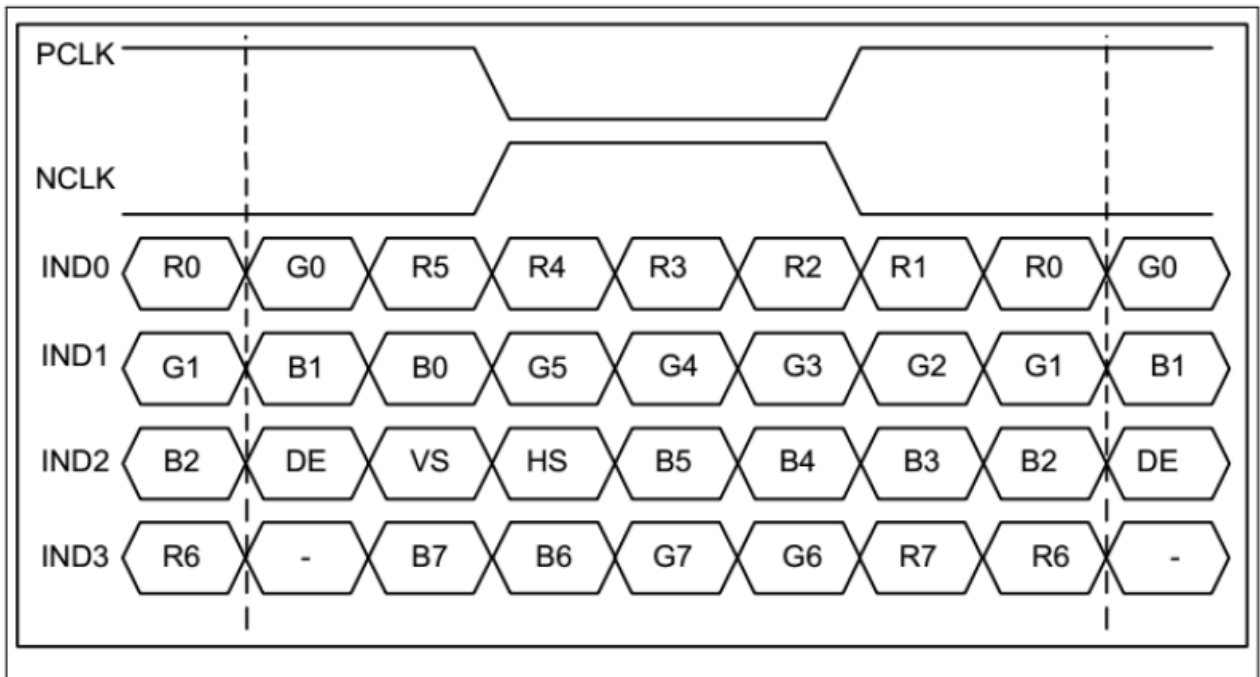

8-bit LVDS Input Timing chart

**8. RELIABILITY TEST**

<b>NO.</b>	<b>TEST ITEM</b>	<b>CONDITIONS</b>	
1	HIGH TEMPERATURE STORAGE	TA=80°C	96H
2	LOW TEMPERATURE STORAGE	TA=-30°C	96H
3	HIGH TEMPERATURE OPERATION	TA=70 °C	96H
4	LOW TEMPERATURE OPERATION	TA=-20°C	96H
5	HIGH TEMPERATURE AND HIGH HUMIDITY OPERATION	+60°C, 90%RH	96H
6	THERMAL SHOCK	-30°C → +80°C,	0.5H: 5CYCLES

## **9. LCD MODULES HANDLING PRECAUTIONS**

- n** The display panel is made of glass. Do not subject it to a mechanical shock by dropping it from a high place, etc.
- n** If the display panel is damaged and the liquid crystal substance inside it leaks out, do not get any in your mouth. If the substance come into contact with your skin or clothes promptly wash it off using soap and water.
- n** Do not apply excessive force to the display surface or the adjoining areas since this may cause the color tone to vary.
- n** The polarizer covering the display surface of the LCD module is soft and easily scratched. Handle this polarize carefully.
- n** To prevent destruction of the elements by static electricity, be careful to maintain an optimum work environment.
  - Be sure to ground the body when handling the LCD module.
  - Tools required for assembly, such as soldering irons, must be properly grounded.
  - To reduce the amount of static electricity generated, do not conduct assembly and other work under dry conditions.
  - The LCD module is coated with a film to protect the display surface. Exercise care when peeling off this protective film since static electricity may be generated.
- n** Storage precautions  
When storing the LCD modules, avoid exposure to direct sunlight or to the light of fluorescent lamps. Keep the modules in bags designed to prevent static electricity charging under low temperature / normal humidity conditions (avoid high temperature / high humidity and low temperatures below 0°C).Whenever possible, the LCD modules should be stored in the same conditions in which they were shipped from our company.

## **10. OTHERS**

- n** Liquid crystals solidify at low temperature (below the storage temperature range) leading to defective orientation of liquid crystal or the generation of air bubbles (black or white). Air bubbles may also be generated if the module is subjected to a strong shock at a low temperature.
- n** If the LCD modules have been operating for a long time showing the same display patterns may remain on the screen as ghost images and a slight contrast irregularity may also appear. Abnormal operating status can be resumed to be normal condition by suspending use for some time. It should be noted that this phenomena does not adversely affect performance reliability.
- n** To minimize the performance degradation of the LCD modules resulting from caused by static electricity, etc. exercise care to avoid holding the following sections when handling the modules:
  - Exposed area of the printed circuit board
  - Terminal electrode sections.