

Display Elektronik GmbH

DATA SHEET

LCD MODULE

DEM 1024768A TMX-PW-N

12,1" TFT

Product Specification

Ver.:0

18.07.2013

Revise Records

Rev.	Date	Contents	Written	Approved
0	18.07.2013	Preliminary Specification	KH	RY

Special Notes

Note1.	
Note2.	
Note3.	
Note4.	
Note5.	

Contents

1.	General Description and Features	4
1.1	Features	4
1.2	LCD Module	4
2.	Mechanical Information	4
3.	Electrical Specifications	5
3.1	Absolute Max. Ratings	5
4.	Optical Characteristics	12
4.1	Optical characteristic of the LCD	12
5.	I/O Terminal	14
5.1	Pin Assignment	14
5.2	Back-light (CN2:91208-01001-H01 (AES) or Equivalent)	15
5.3	Block Diagram	16
6.	Displayed Color and Input Data	17
6.1	6 bit Input Data	17
6.2	8 bit Input Data	18
7.	Reliability Condition	19
8.	Dimensional Outlines	20

1. General Description and Features

DEM 1024768A TMX-PW-N is a transmissive type color active matrix TFT (Thin Film Transistor) liquid crystal display (LCD) that uses amorphous silicon TFT as a switching device. This model is composed of a TFT-LCD module, a receiver circuit, and a backlight unit. Graphics and texts can be displayed on a XGA 1024 (W) x RGB x 768 (H) dots (4:3 aspect ratio) with 262,144/16.2M colors by supplying 18/24 bits data signal (6/8 bits each color). The following table described the features:

1.1 Features

- Transmissive.
- TN (Twisted Nematic) Mode.
- LVDS Receiver 18/24 bit Interface.
- Backlight Dimming Control

1.2 LCD Module

Item	Specification	Unit
Screen Size	12.1 inches	Diagonal
Display Resolution	1024 x RGB x 768	Pixel
Active Area	245.76 x 184.32	mm
Outline Dimension	260.50 x 204.00 x 8.40	mm
Display Mode	Normally White Mode/ Transmissive	--
Surface Treatment	Hard coating(3H), Glare	--
Pixel Arrangement	R,G,B Vertical Stripe	--
Pixel Size	240 x 240	μm
Display Color	262k/16.2M	--
Viewing Direction	6 O'clock	--
Input Interface	LVDS Receiver 18/24 bit Interface	--

2. Mechanical Information

Item	Min.	Typ.	Max.	Unit	Note	
Module Size	Horizontal (H)	260.2	260.5	260.8	mm	(1)
	Vertical (V)	239.7	204	204.3	mm	
	Thickness (T)	7.9	8.4	8.9	mm	
Weight	--	510	540	g	--	

Note (1) Please refer to the attached drawings for more information of front and back outline dimensions.

3. Electrical Specifications

3.1 Absolute Max. Ratings

3.1.1 Absolute Ratings of Environment

If the operating condition exceeds the following absolute maximum ratings, the TFT LCD module may be damaged permanently.

Item	Symbol	Min.	Max.	Unit	Note
Storage temperature	T _{STG}	-40	85	°C	(1)
Operating temperature	T _{OPR}	-30	80	°C	(1,2,3)

Note (1) 90 % RH Max. (40 °C ≥ Ta). Maximum wet-bulb temperature at 39 °C or less. (Ta > 40 °C) No condensation.

Note (2) In case of below 0°, the response time of liquid crystal (LC) becomes slower and the color of panel becomes darker than normal one. Level of retardation depends on temperature, because of LC's character

Note (3) Only operation is guaranteed at operating temperature. Contrast, response time, another display quality are evaluated at +25°C.

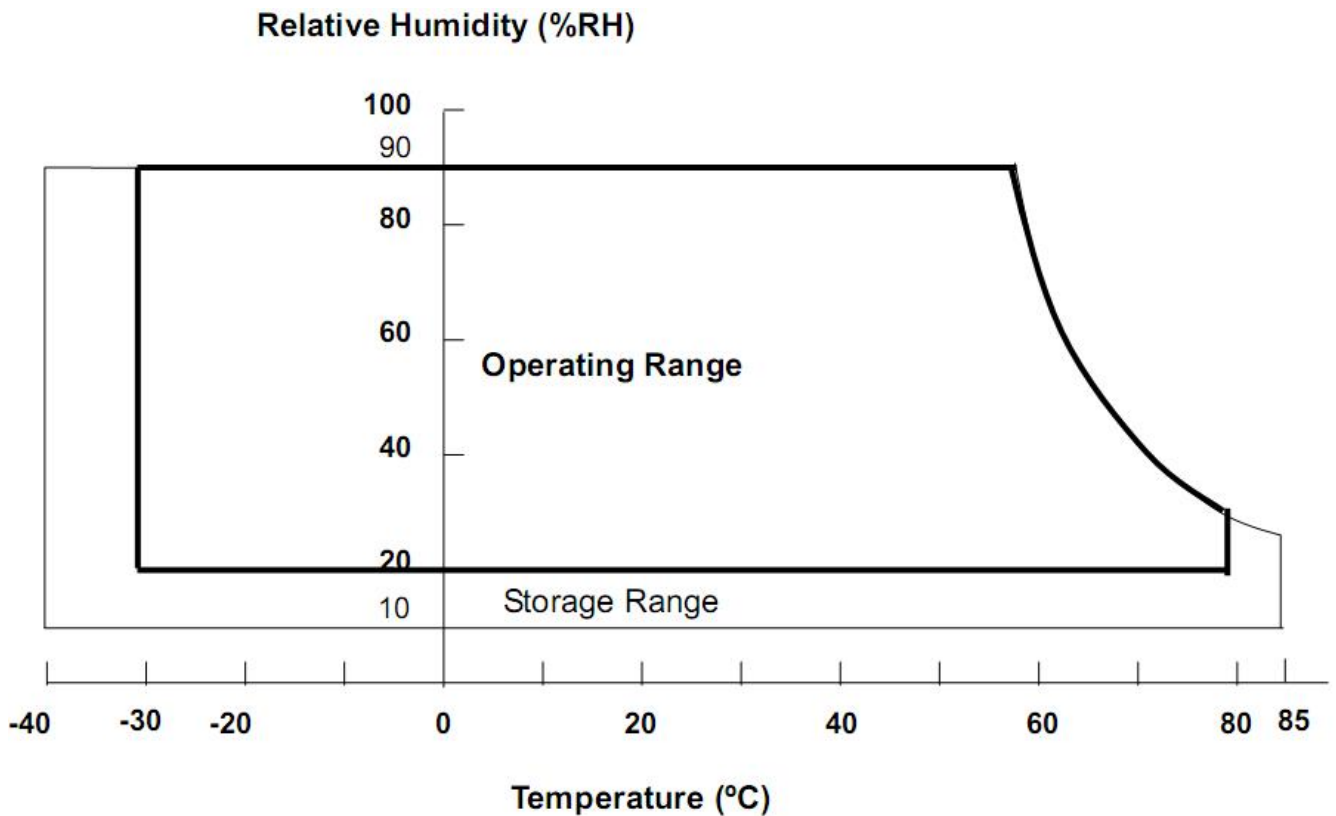

3.1.2 Electrical Absolute Maximum Ratings

(V_{SS}=GND=0)

Parameter	Symbol	Min.	Max.	Unit	Remark
Power supply logic voltage	VCC	-0.3	7.0	V	(1)
Power supply LED voltage	VLED	-0.3	18	V	(1),(2)
LED Enable voltage	EN	--	5.5	V	
Back-light Adjust	ADJ	--	5.5	V	

Note (1) Permanent damage to the device may occur if maximum values are exceeded. Function operation should be restricted to the conditions described under Normal Operating Conditions.

Note (2) Specified values are for lamp (Refer to 3.2 for further information).

3.1.3 DC Electrical Characteristics of the TFT LCD

(T_a=25±2°C, GND=0)

Item	Symbol	Min.	Typ.	Max.	Unit	Remark
Power supply Logic Voltage	VCC	3.0	3.3	3.6	V	(1)VCC=3.3V
	VCC	4.75	5.0	5.25	V	(1)VCC=5.0V
Rush Current	I _{RUSH}	-	-	4	A	(2)
Power supply Logic Current	ICC(white)	-	410	490	mA	(3)VCC=3.3V
	ICC(white)	-	320	395	mA	(3)VCC=5.0V
	ICC(black)	-	540	650	mA	(3)VCC=3.3V
	ICC(black)	-	400	480	mA	(3)VCC=5.0V
Power Logic Consumption	P _{LCD}	-	2.0	-	W	
LVDS differential input voltage	VID	100	-	600	mV	
LVDS common input voltage	VICM	0.7	-	1.6	V	

Note (1) The assembly should be always operated within above ranges.

Note (2) Measurement Conditions:

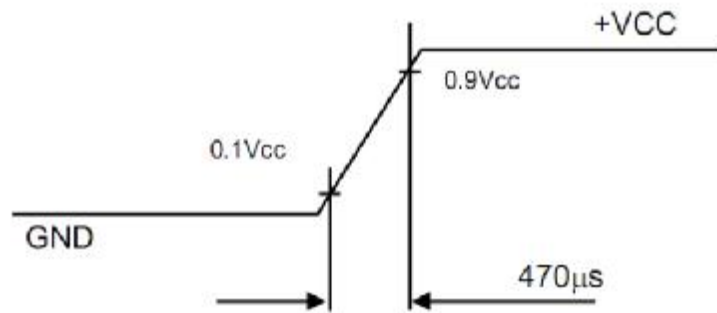
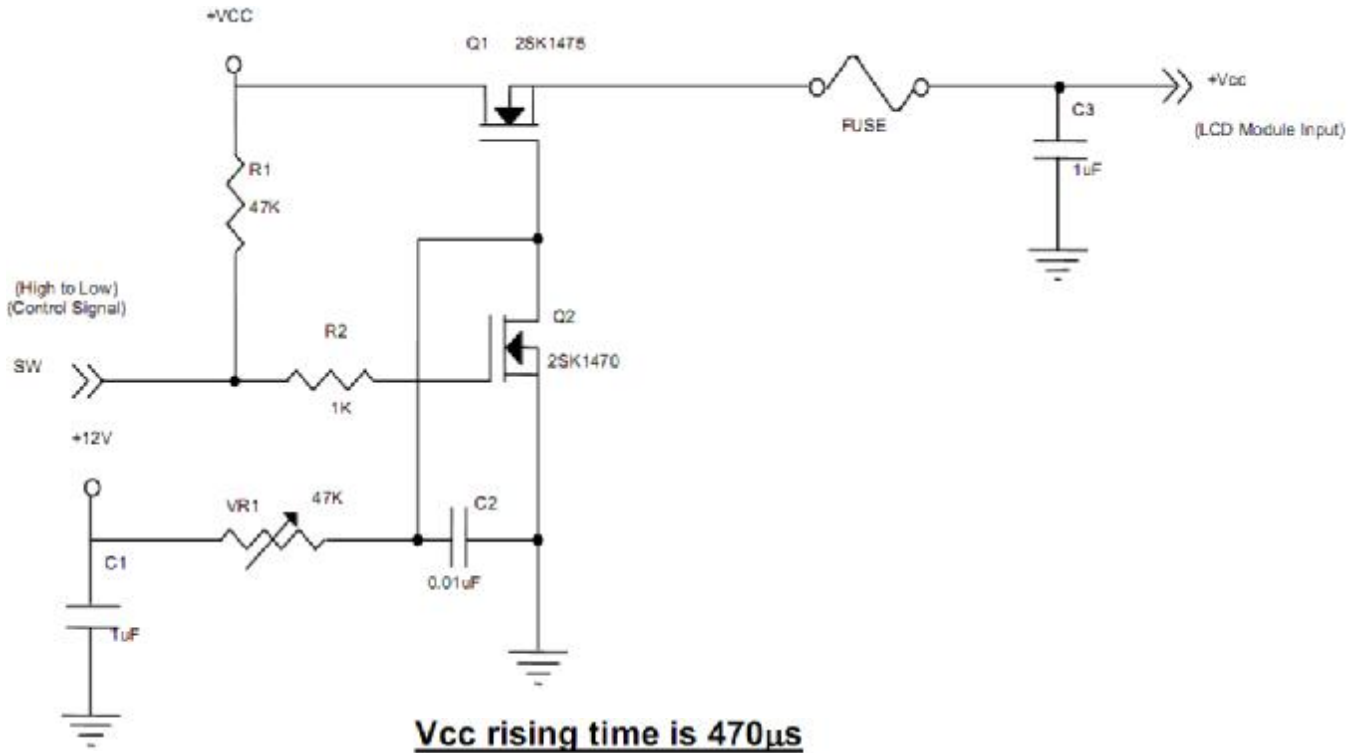

Note (3) The specified power supply current is under the conditions at VCC = 3.3V or 5V, Ta = 25 ± 2 °C, fv = 60 Hz, whereas a power dissipation check pattern below is displayed.

a. White Pattern



Active Area

b. Black Pattern



Active Area

3.1.4 DC Electrical Characteristics of the Back-light Unit

(Ta=25±2°C, GND=0)

Item	Symbol	Min.	Typ.	Max.	Unit	Remark	
Power supply LED Voltage	VLED	7.0	12.0	17.0	V		
Power supply LED Current	ILED	0.7	0.83	0.9	A	VLED=12V (Duty 100%)	
LED Power Consumption	PLED	-	10.0	-	W	VLED=12V (Duty 100%)	
EN Control Level	Backlight on	-	2.0	3.3	5.0	V	
	Backlight off	-	0	-	0.8	V	
PWM Control Level	High	-	2.0	3.3	5.0	V	
	Low	-	0	-	0.15	V	
PWM Control Duty Ratio	-	10	-	100	%		
PWM Control Frequency	f _{PWM}	190	200	210	Hz		
LED Life Time	L _L	50,000	-	-	Hrs	(2)	

Note (1) LED current is measured by utilizing a high frequency current meter as shown below:

Note (2) The lifetime of LED is defined as the time when it continues to operate under the conditions at

Ta = 25 ±2 °C and Duty 100% until the brightness becomes ≤ 50% of its original value.

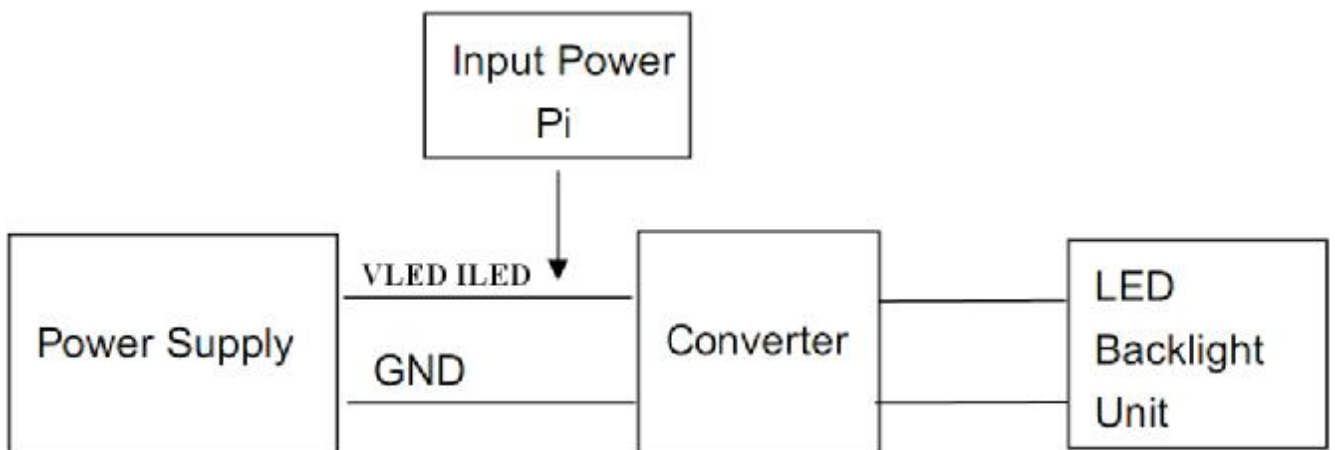

3.1.5 AC Timing Condition

Signal	Parameter	Symbol	Min.	Typ.	Max.	Unit.	Remark
DCLK	CLK frequency	F_c	57.5	64.9	74.4	MHz	
Horizontal Timing	Total	T_h	1240	1344	1464	Tc	$T_h = T_{hd} + T_{hb}$
	Display	T_{hd}	-	1024	-	Tc	
	Blank	T_{hb}	216	320	440	Tc	
Vertical Timing	Total	T_v	774	806	848	Th	$T_v = T_{vd} + T_{vb}$
	Display	T_{vd}	-	768	-	Th	
	Blank	T_{vb}	6	38	80	Th	

Note (1) Since this assembly is operated in DE only mode, Hsync and Vsync input signals should be set to low logic level. Otherwise, this assembly would operate abnormally.

(2) Frame rate is 60Hz

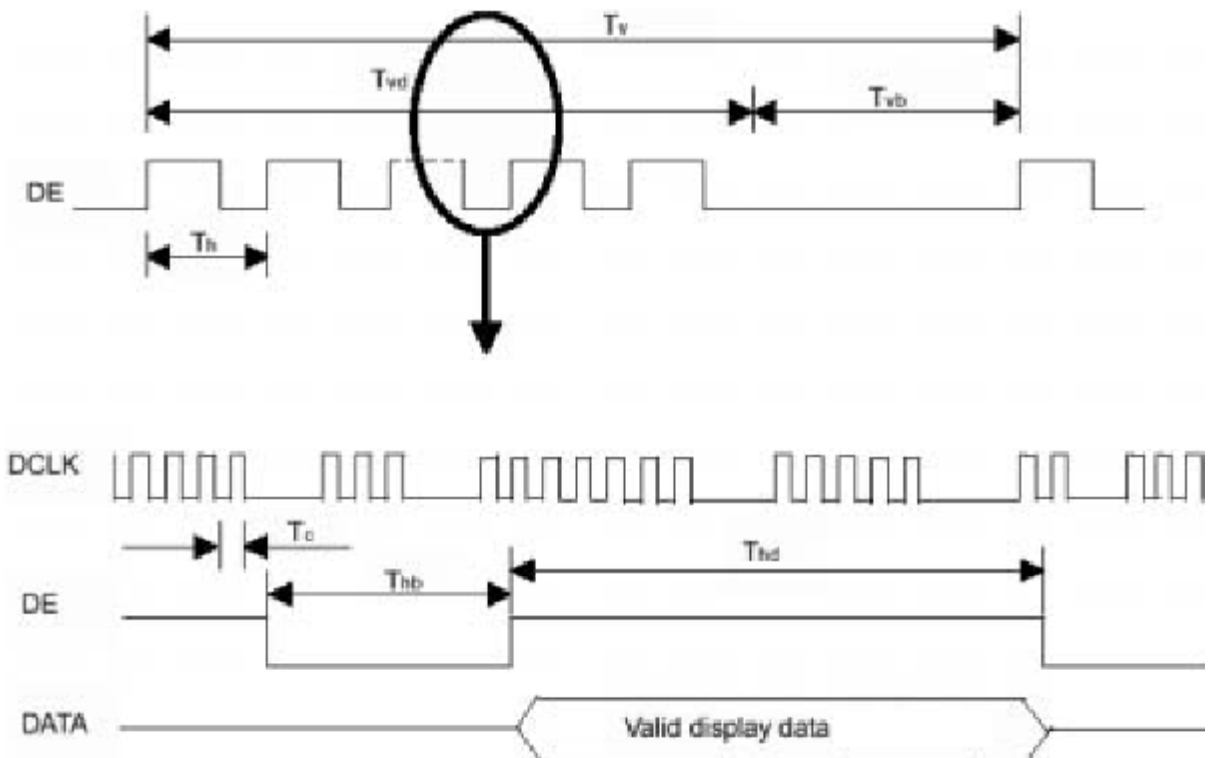

3.1.6 Timing Characteristic

SEL68 = "Low" or "NC" for 6 bits LVDS Input

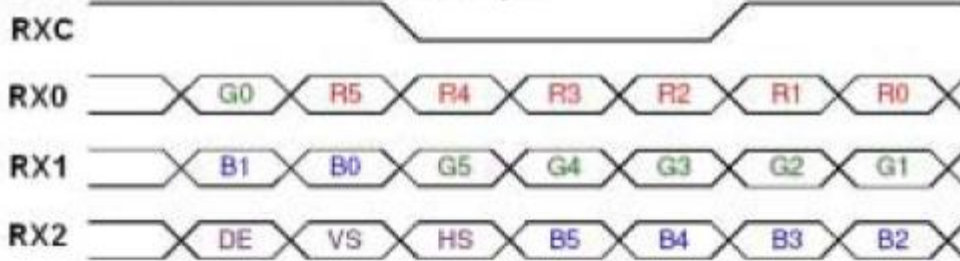

SEL68 = "High" for 8 bits LVDS Input

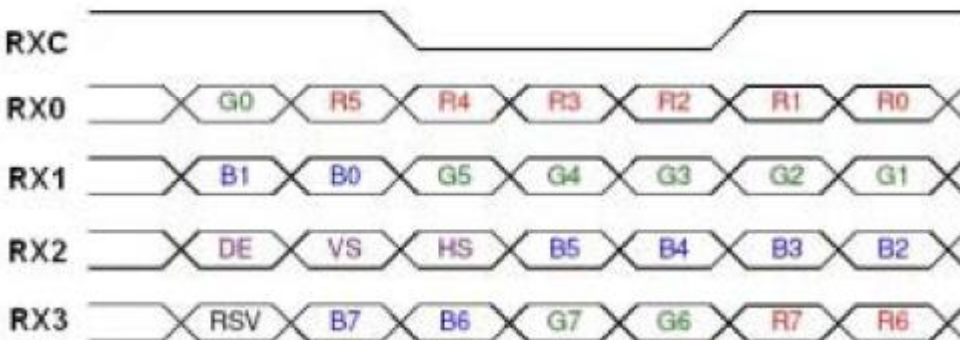

Note (1) R/G/B data 7: MSB, R/G/B data 0: LSB

Note (2) please follow PSWG

Signal Name	Description	Remark
R7 R0	Red Data 7(MSB) Red Data 0(LSB)	Red-pixel Data Each red pixel's brightness data consists of these 8 bits pixel data.
G7 G0	Green Data 7(MSB) Green Data 0(LSB)	Green-pixel Data Each green pixel's brightness data consists of these 8 bits pixel data.
B7 B0	Blue Data 7(MSB) Blue Data 0(LSB)	Blue-pixel Data Each blue pixel's brightness data consists of these 8 bits pixel data.
RXCLKIN+ RXCLKIN-	LVDS Clock Input	
DE	Display Enable	
VS	Vertical Sync	
HS	Horizontal Sync	

Note (3) Output signals from any system shall be low or Hi-Z state when VCC is off.

3.1.7 Power On/Off Sequence

To prevent a latch-up or DC operation of LCD assembly, the power on/off sequence should be as the diagram below.

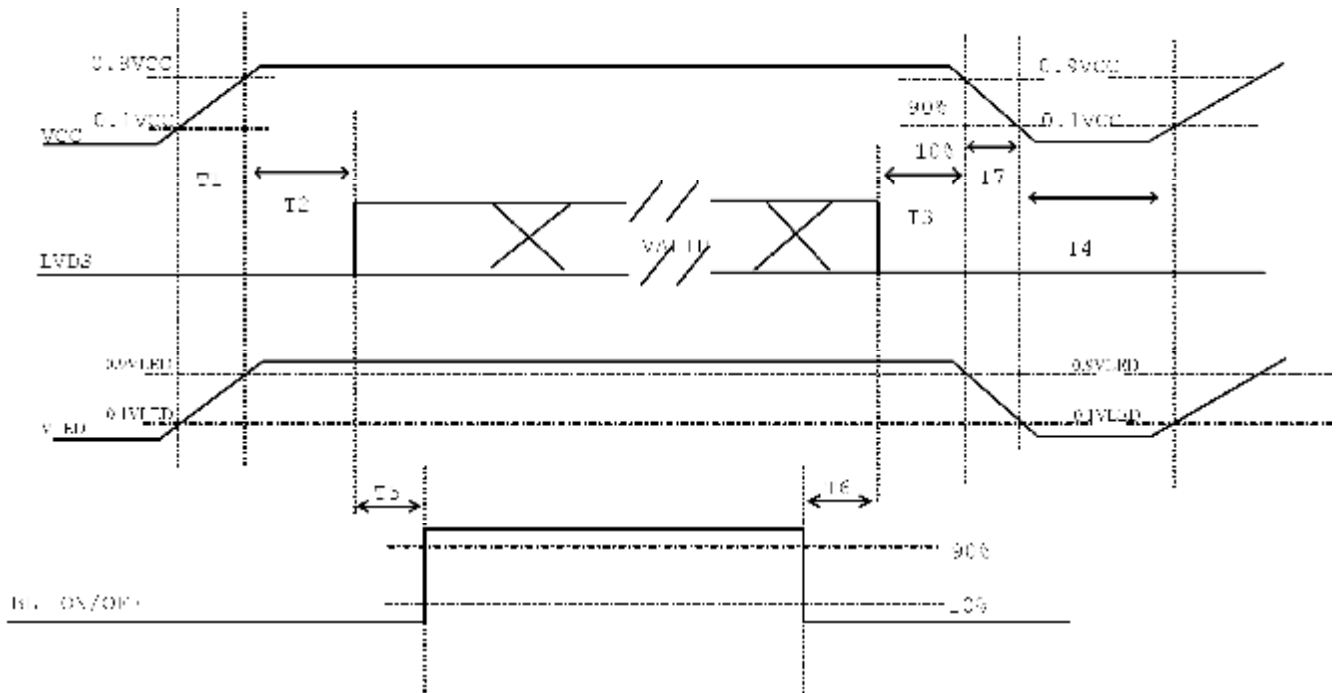

Note (1) Please avoid floating state of interface signal at invalid period.

Note (2) When the interface signal is invalid; be sure to pull down the power supply of LCD VCC to 0 V.

Note (3) The Backlight converter power must be turned on after the power supply for the logic and the interface signal is valid. The Backlight converter power must be turned off before the power supply for the logic and the interface signal is invalid.

Parameter	Value			Units
	Min.	Typ.	Max.	
T1	0.5	-	10	ms
T2	0	-	50	ms
T3	0	-	50	ms
T4	500	-	-	ms
T5	200	-	-	ms
T6	200	-	-	ms
T7	5	-	300	ms

4. Optical Characteristics

4.1 Optical characteristic of the LCD

The following items are measured under stable conditions. The optical characteristics should be measured in a dark room or equivalent state with the methods.

Measuring equipment: BM-7A

Ta=25±2°C ; Ha=50±10%RH

Item	Symbol	Condition	Min	Type	Max	Unit	Note
Brightness	B		(500)	(600)	--	cd/m ²	
Response time	Tr	θ=0°	-	5	10	ms	
	Tf		--	11	16	ms	
Contrast ratio	CR	At optimized viewing angle	(500)	(700)	--	--	
Luminance Uniformity	ΔL		70	75		%	
Color Chromaticity (CIE 1931)	White	x	(0.263)	(0.313)	(0.363)	--	BM-7A
		y	(0.279)	(0.329)	(0.379)		
	Red	x	(0.575)	(0.625)	(0.675)		
		y	(0.308)	(0.358)	(0.408)		
	Green	x	(0.274)	(0.324)	(0.374)		
		y	(0.554)	(0.604)	(0.654)		
	Blue	x	(0.094)	(0.144)	(0.194)		
		y	(0.038)	(0.088)	(0.138)		
Viewing Angle (6H)	Hor.	θ _R	70	80	--	Degree	
		θ _L	70	80	--		
	Ver.	θ _U	60	70	--		
		θ _D	60	70	--		

a. Test equipment setup

After stabilizing and leaving the panel alone shall be warmed up for the stable operation of LCM, the measurement should be executed. Measurement should be executed in a stable, windless, and dark room. Optical specifications are measured by Topcon BM-7A(fast) with a viewing angle of 2° at a distance of 50cm and normal direction.

b. Definition of response time: Tr and Tf

The response time is defined as the following figure and shall be measured by switching the input signal for "black" and "white".

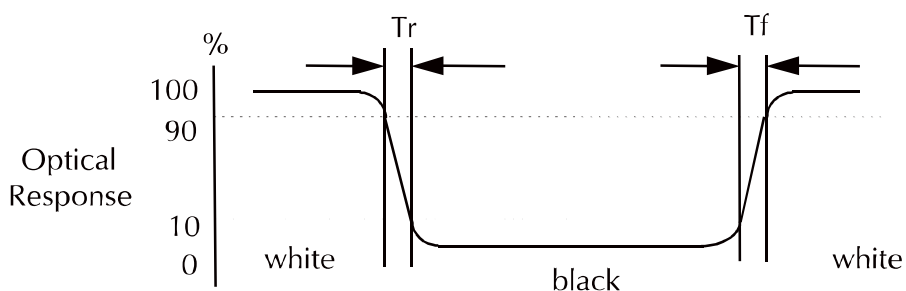

c. Definition of contrast ratio:

$$\text{Contrast Ratio (CR)} = \frac{\text{Brightness measured when LCD is at "white state"}}{\text{Brightness measured when LCD is at "black state"}}$$

d. Measured at the center area of the panel when all the input terminals of LCD panel are electrically opened.

e. View Angle

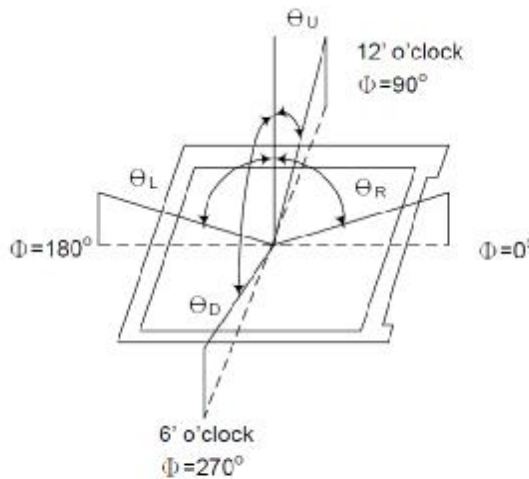

f. Definition of Luminance of White: Luminance of white at the center points

Light Source of Back-Light Unit	LED Type
---------------------------------	----------

g. Definition of White Uniformity

$$\text{White Uniformity} = \frac{\text{Min. luminance of white among 5-points}}{\text{Max. luminance of white among 5-points}} \times 100\%$$

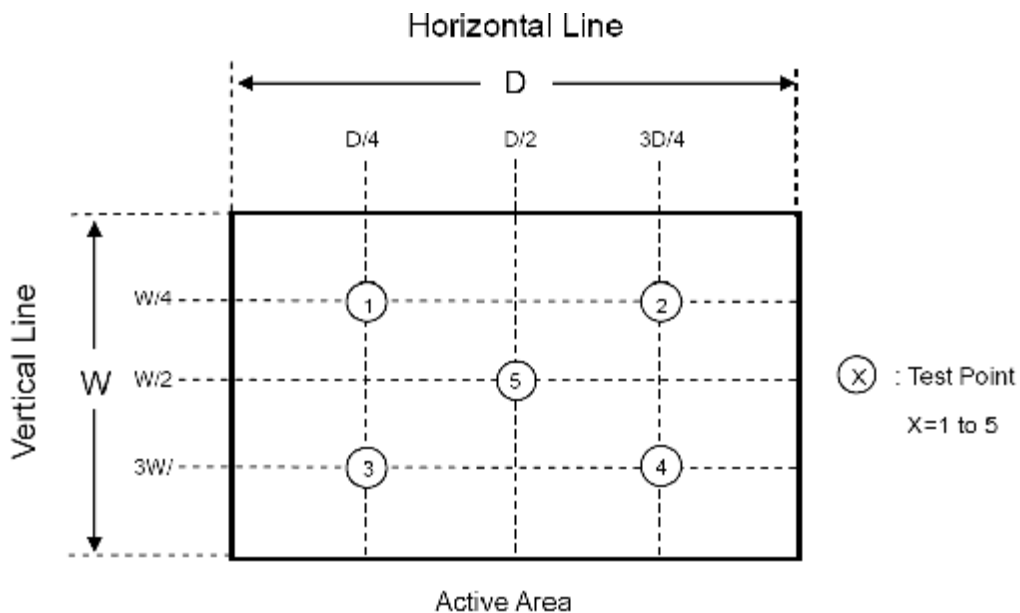

5. I/O Terminal

5.1 Pin Assignment

(CN1 connector: STARCONN 076B20-0048RA-G4 or JAE FI-SEB20P-HFE or equivalent.)

Pin No.	Symbol	I/O	Function	Remark
1	RX3+	I	Positive LVDS differential data input	
2	RX3-	I	Negative LVDS differential data input	
3	NC	-	No Connect	
4	SEL68	I	LVDS 6/8 bit select function control	Note (1)
5	GND	P	Ground	
6	RXC+	I	Positive LVDS differential clock input	
7	RXC-	I	Negative LVDS differential clock input	
8	GND	P	Ground	
9	RX2+	I	Positive LVDS differential data input	
10	RX2-	I	Negative LVDS differential data input	
11	GND	P	Ground	
12	RX1+	I	Positive LVDS differential data input	
13	RX1-	I	Negative LVDS differential data input	
14	GND	P	Ground	
15	RX0+	I	Positive LVDS differential data input	
16	RX0-	I	Negative LVDS differential data input	
17	LR	I	Horizontal Reverse Scan Control	Note (2)
18	UD	I	Vertical Reverse Scan Control	
19	VCC	P	Power Supply Logic voltage	
20	VCC	P	Power Supply Logic voltage	

I: Input, O: Output, P: Power

Note (1) When use 6bit Input mode: SEL68 = GND or NC

When use 8bit Input mode: SEL68 = VCC

Note (2)

Scan Control Input		Scanning Direction
UD	LR	
GND/NC	GND/NC	Up to Down, Left to Right
GND/NC	VCC	Up to Down, Right to Left
VCC	GND/NC	Down to Up, Left to Right
VCC	VCC	Down to Up, Right to Left

5.2 Backlight (CN2:91208-01001-H01 (AES) or Equivalent)

Pin No.	Symbol	I/O	Function	Remark
1	VLED	P	Power Supply voltage +12V	
2	VLED	P	Power Supply voltage +12V	
3	VLED	P	Power Supply voltage +12V	
4	VLED	P	Power Supply voltage +12V	
5	GND	P	Ground	
6	GND	P	Ground	
7	GND	P	Ground	
8	GND	P	Ground	
9	EN	I	Enable pin	
10	ADJ	I	Backlight Adjust	

Note (1) User's connector: 91209-01011 (AES) or Equivalent.

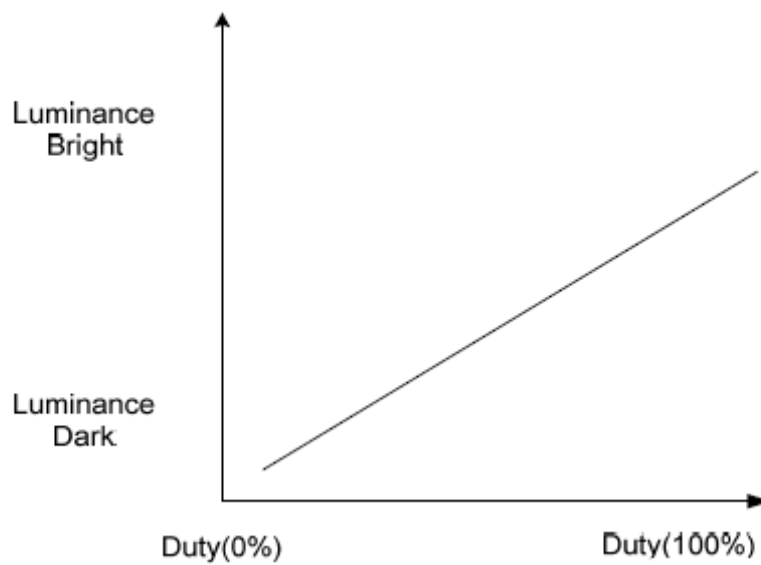

Note 2: ADJ signal=0~3.3V, Operating frequency: 190~210Hz

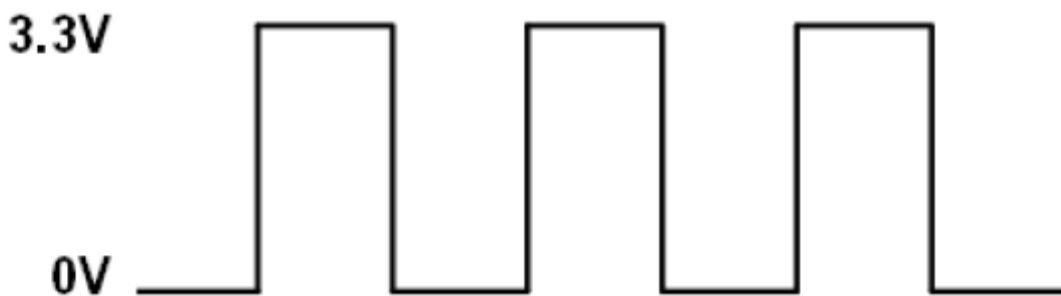

5.3 Block Diagram

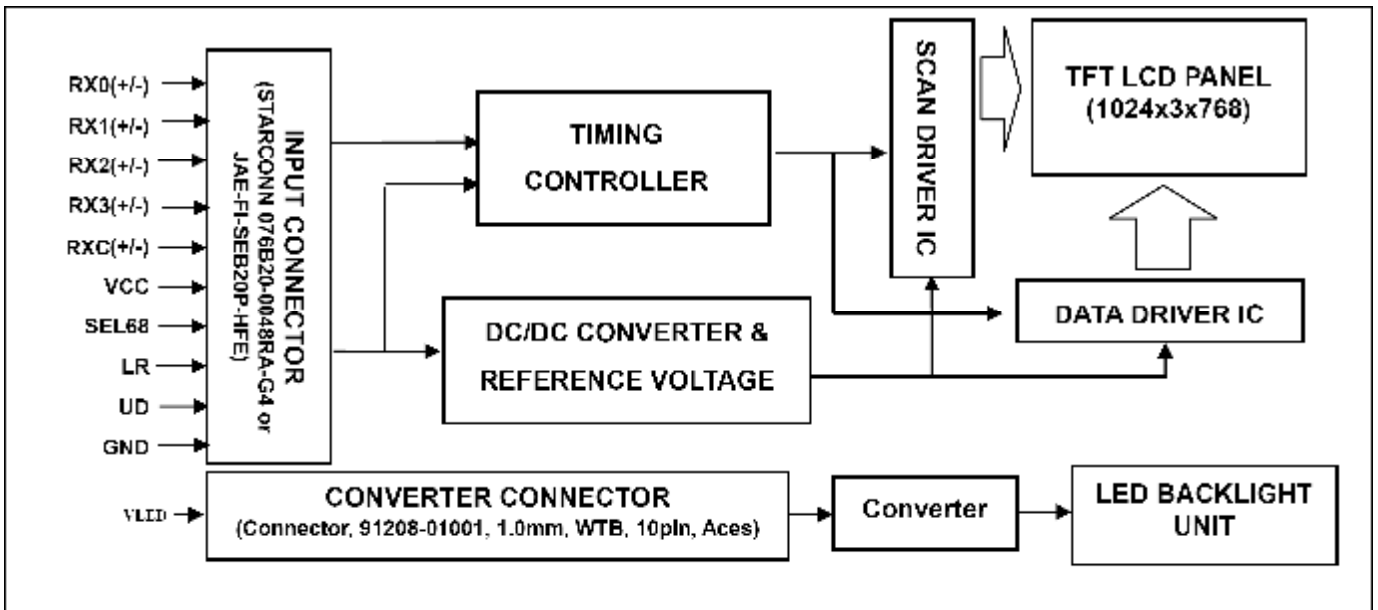

6. Displayed Color and Input Data

6.1 6 bit Input Data

	Color & Gray Scale	Data Signal																	
		R5	R4	R3	R2	R1	R0	G5	G4	G3	G2	G1	G0	B5	B4	B3	B2	B1	B0
Basic Color	Black	0	0	0	0	0	0	0	0	0	0	0	0	0	0	0	0	0	0
	Red(0)	1	1	1	1	1	1	0	0	0	0	0	0	0	0	0	0	0	0
	Green(0)	0	0	0	0	0	0	1	1	1	1	1	1	0	0	0	0	0	0
	Blue(0)	0	0	0	0	0	0	0	0	0	0	0	0	1	1	1	1	1	1
	Cyan	0	0	0	0	0	0	1	1	1	1	1	1	1	1	1	1	1	1
	Magenta	1	1	1	1	1	1	0	0	0	0	0	0	1	1	1	1	1	1
	Yellow	1	1	1	1	1	1	1	1	1	1	1	1	0	0	0	0	0	0
	White	1	1	1	1	1	1	1	1	1	1	1	1	1	1	1	1	1	1
Red	Black	0	0	0	0	0	0	0	0	0	0	0	0	0	0	0	0	0	0
	Red(62)	0	0	0	0	0	1	0	0	0	0	0	0	0	0	0	0	0	0
	Red(61)	0	0	0	0	1	0	0	0	0	0	0	0	0	0	0	0	0	0
	:	:	:	:	:	:	:	:	:	:	:	:	:	:	:	:	:	:	:
	Red(31)	0	1	1	1	1	1	0	0	0	0	0	0	0	0	0	0	0	0
	:	:	:	:	:	:	:	:	:	:	:	:	:	:	:	:	:	:	:
	Red(1)	1	1	1	1	1	0	0	0	0	0	0	0	0	0	0	0	0	0
	Red(0)	1	1	1	1	1	1	0	0	0	0	0	0	0	0	0	0	0	0
Green	Black	0	0	0	0	0	0	0	0	0	0	0	0	0	0	0	0	0	0
	Green(62)	0	0	0	0	0	0	0	0	0	0	0	1	0	0	0	0	0	0
	Green(61)	0	0	0	0	0	0	0	0	0	0	1	0	0	0	0	0	0	0
	:	:	:	:	:	:	:	:	:	:	:	:	:	:	:	:	:	:	:
	Green(31)	0	0	0	0	0	0	0	1	1	1	1	1	0	0	0	0	0	0
	:	:	:	:	:	:	:	:	:	:	:	:	:	:	:	:	:	:	:
	Green(1)	0	0	0	0	0	0	1	1	1	1	1	1	0	0	0	0	0	0
	Green(0)	0	0	0	0	0	0	1	1	1	1	1	1	0	0	0	0	0	0
Blue	Black	0	0	0	0	0	0	0	0	0	0	0	0	0	0	0	0	0	0
	Blue(62)	0	0	0	0	0	0	0	0	0	0	0	0	0	0	0	0	0	1
	Blue(61)	0	0	0	0	0	0	0	0	0	0	0	0	0	0	0	0	1	0
	:	:	:	:	:	:	:	:	:	:	:	:	:	:	:	:	:	:	:
	Blue(31)	0	0	0	0	0	0	0	0	0	0	0	0	0	1	1	1	1	1
	:	:	:	:	:	:	:	:	:	:	:	:	:	:	:	:	:	:	:
	Blue(1)	0	0	0	0	0	0	0	0	0	0	0	0	1	1	1	1	1	0
	Blue(0)	0	0	0	0	0	0	0	0	0	0	0	0	1	1	1	1	1	1

0 : Low level voltage, 1 :High level voltage

Each basic color can be displayed in 64 gray scales from 6 bit data signals. With the combination of total 18 bit data signals, the 262,144-color display can be achieved on the screen.

6.2 8 bit Input Data

	Color & Gray Scale	Data Signal																							
		R7	R6	R5	R4	R3	R2	R1	R0	G7	G6	G5	G4	G3	G2	G1	G0	B7	B6	B5	B4	B3	B2	B1	B0
Basic Color	Black	0	0	0	0	0	0	0	0	0	0	0	0	0	0	0	0	0	0	0	0	0	0	0	0
	Red(0)	1	1	1	1	1	1	1	1	0	0	0	0	0	0	0	0	0	0	0	0	0	0	0	0
	Green(0)	0	0	0	0	0	0	0	0	1	1	1	1	1	1	1	1	0	0	0	0	0	0	0	0
	Blue(0)	0	0	0	0	0	0	0	0	0	0	0	0	0	0	0	0	1	1	1	1	1	1	1	1
	Cyan	0	0	0	0	0	0	0	0	1	1	1	1	1	1	1	1	1	1	1	1	1	1	1	1
	Magenta	1	1	1	1	1	1	1	1	0	0	0	0	0	0	0	0	1	1	1	1	1	1	1	1
	Yellow	1	1	1	1	1	1	1	1	1	1	1	1	1	1	1	1	0	0	0	0	0	0	0	0
	White	1	1	1	1	1	1	1	1	1	1	1	1	1	1	1	1	1	1	1	1	1	1	1	1
Red	Black	0	0	0	0	0	0	0	0	0	0	0	0	0	0	0	0	0	0	0	0	0	0	0	0
	Red(255)	0	0	0	0	0	0	0	1	0	0	0	0	0	0	0	0	0	0	0	0	0	0	0	0
	Red(254)	0	0	0	0	0	0	1	0	0	0	0	0	0	0	0	0	0	0	0	0	0	0	0	0
	:	:	:	:	:	:	:	:	:	:	:	:	:	:	:	:	:	:	:	:	:	:	:	:	:
	Red(31)	0	0	0	1	1	1	1	1	0	0	0	0	0	0	0	0	0	0	0	0	0	0	0	0
	:	:	:	:	:	:	:	:	:	:	:	:	:	:	:	:	:	:	:	:	:	:	:	:	:
	Red(1)	1	1	1	1	1	1	1	0	0	0	0	0	0	0	0	0	0	0	0	0	0	0	0	0
	Red(0)	1	1	1	1	1	1	1	1	0	0	0	0	0	0	0	0	0	0	0	0	0	0	0	0
Green	Black	0	0	0	0	0	0	0	0	0	0	0	0	0	0	0	0	0	0	0	0	0	0	0	0
	Green(255)	0	0	0	0	0	0	0	0	0	0	0	0	0	0	0	1	0	0	0	0	0	0	0	0
	Green(254)	0	0	0	0	0	0	0	0	0	0	0	0	0	0	1	0	0	0	0	0	0	0	0	0
	:	:	:	:	:	:	:	:	:	:	:	:	:	:	:	:	:	:	:	:	:	:	:	:	:
	Green(31)	0	0	0	0	0	0	0	0	0	0	0	1	1	1	1	0	0	0	0	0	0	0	0	0
	:	:	:	:	:	:	:	:	:	:	:	:	:	:	:	:	:	:	:	:	:	:	:	:	:
	Green(1)	0	0	0	0	0	0	0	0	1	1	1	1	1	1	1	0	0	0	0	0	0	0	0	0
	Green(0)	0	0	0	0	0	0	0	0	1	1	1	1	1	1	1	1	0	0	0	0	0	0	0	0
Blue	Black	0	0	0	0	0	0	0	0	0	0	0	0	0	0	0	0	0	0	0	0	0	0	0	0
	Blue(255)	0	0	0	0	0	0	0	0	0	0	0	0	0	0	0	0	0	0	0	0	0	0	0	1
	Blue(254)	0	0	0	0	0	0	0	0	0	0	0	0	0	0	0	0	0	0	0	0	0	0	1	0
	:	:	:	:	:	:	:	:	:	:	:	:	:	:	:	:	:	:	:	:	:	:	:	:	:
	Blue(31)	0	0	0	0	0	0	0	0	0	0	0	0	0	0	0	0	0	0	0	1	1	1	1	1
	:	:	:	:	:	:	:	:	:	:	:	:	:	:	:	:	:	:	:	:	:	:	:	:	:
	Blue(1)	0	0	0	0	0	0	0	0	0	0	0	0	0	0	0	0	1	1	1	1	1	1	1	0
	Blue(0)	0	0	0	0	0	0	0	0	0	0	0	0	0	0	0	0	1	1	1	1	1	1	1	1

0 : Low level voltage, 1 :High level voltage

Each basic color can be displayed in 256 gray scales from 6 bit data signals. With the combination of total 24 bit data signals, the 16.2M-color display can be achieved on the screen.

7. Reliability Condition

No change on display and in operation under the following test condition.

Condition: Unless otherwise specified, tests will be conducted under the following condition.

Temperature: 20±5°C.

Humidity: 50±10%RH.

Tests will be not conducted under functioning state.

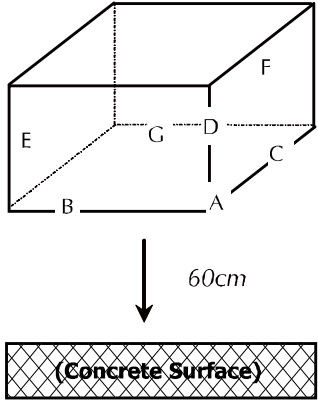
No.	Parameter	Condition	Notes
1	High Temperature Operating	80°C±2°C, 240hrs (Operation state).	
2	Low Temperature Operating	-30°C±2°C, 240hrs (Operation state).	1
3	High Temperature Storage	85°C±2°C, 240hrs.	2
4	Low Temperature Storage	-40°C±2°C, 240hrs.	1,2
5	High Temperature and High Humidity Operation Test	60°C±2°C, 90%, 240hrs.	1,2
6	Vibration Test	Total fixed amplitude: 1.5G. Vibration Frequency: 10~300Hz. One cycle 10 minutes to 3 direction of X, Y, Z each 30 minutes.	3
7	Shock	Total fixed amplitude: 200G. Shock Frequency: half sine wave. One cycle 2 ms to 3 direction of X, Y, Z each 1 time.	
8	Drop Test	To be measured after dropping from 60cm high on the concrete surface in packing state.  <i>Dropping method corner dropping:</i> <i>A corner: Once edge dropping.</i> <i>B, C, D edge: Once face dropping.</i> <i>E, F, G face: Once.</i>	

- Notes:
1. No dew condensation to be observed.
 2. The function test shall be conducted after 4 hours storage at the normal temperature and humidity after removed from the test chamber.
 3. Vibration test will be conducted to the product itself without putting I in a container.

8. Dimensional Outlines

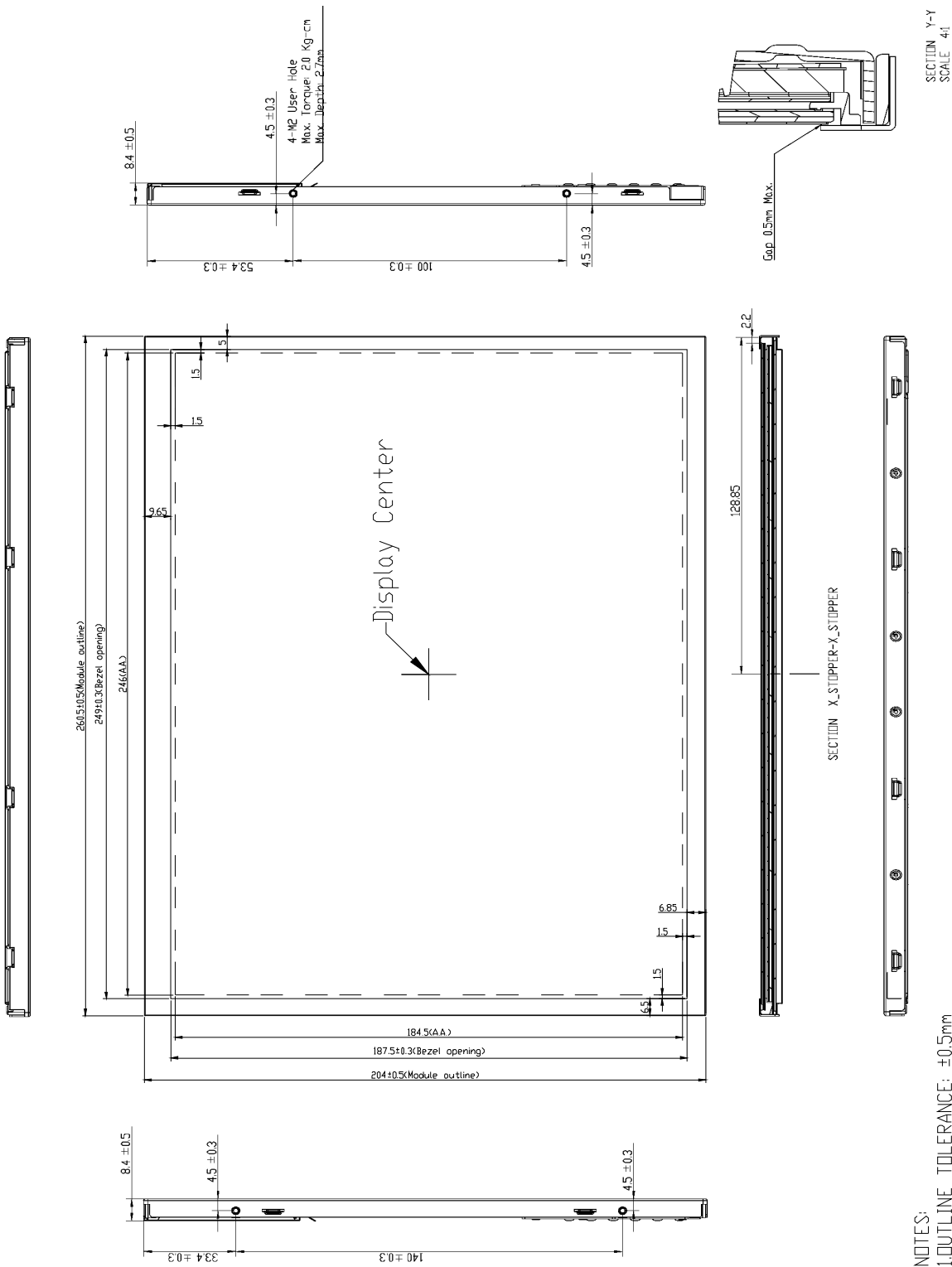

- NOTES:
 1. OUTLINE TOLERANCE: ±0.5mm
 2. "*" MARKS THE DESIGN CRITICAL DIMENSION
 3. "Ⓟ" MARKS THE PROCESS CRITICAL DIMENSION
 4. MAX SCREW LENGTH: 2.7mm
 5. MAX SCREW TORQUE: 2.0 kg-cm.

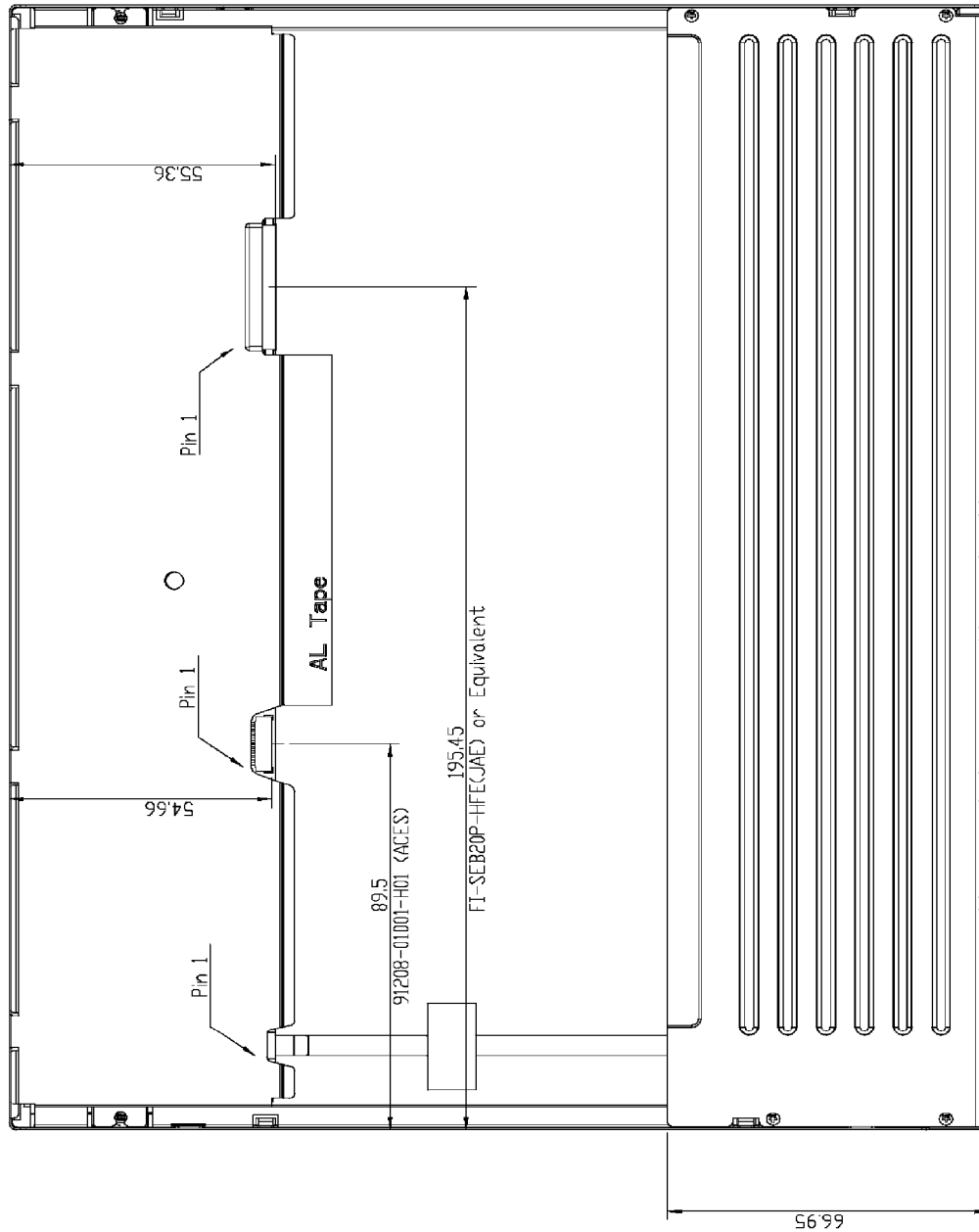

- NOTES:
1. OUTLINE TOLERANCE: ±0.5mm
 2. * * MARKS THE DESIGN CRITICAL DIMENSION
 3. (P) MARKS THE PROCESS CRITICAL DIMENSION
 4. MAX SCREW LENGTH: 2.7mm
 5. MAX SCREW TORQUE: 2.0 kg-cm.