

DISPLAY Elektronik GmbH

DATA SHEET

LCD MODULE

DEM 128064B SYH-PY

Product Specification

Version: 5

21.10.2022

GENERAL SPECIFICATION

MODULE NO. :**DEM 128064B SYH-PY**

CUSTOMER P/N

VERSION	CHANGE DESCRIPTION	DATE
0	ORIGINAL VERSION	15.03.2004
1	CHANGE EXTERNAL DIMENSIONS	06.04.2004
2	CHANGED PCB DRAWING AND DESCRIPTION	05.07.2004
3	ADD VERSION	28.06.2005
4	MODIFY PCB DESCRIPTION	24.03.2006
4.1.0	Change IC	17.06.2008
4.1.1	Change BACKLIGHT DRAWING	04.11.2008
4.1.2	CHANGE AC CHARACTERISTICS	21.05.2014
4.1.3	Change BACKLIGHT DRAWING	04.06.2014
4.1.4	Change BACKLIGHT DRAWING	04.06.2014
5	CHANGE BACKLIGHT RESISTORS	21.10.2022

PREPARED BY: MH

DATE: 21.10.2022

APPROVED BY: MH

DATE: 21.10.2022

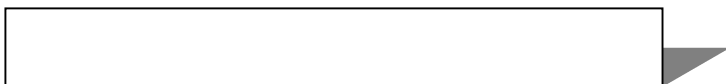

1. FUNCTIONS & FEATURES3

2. MECHANICAL SPECIFICATIONS.....3

3. EXTERNAL DIMENSIONS.....4

5.PIN ASSIGNMENT5

6.1PCB DRAWING AND DESCRIPTION6

7.ABSOLUTE MAXIMUM RATINGS(TA=25°C)8

8. POWER SUPPLY FOR LCD MODULE8

9. ELECTRICAL CHARACTERISTICS9

10. DISPLAY CONTROL INSTRUCTION12

11. BACKLIGHT ELECTRICAL/OPTICAL SPECIFICATIONS.....15

12. OTHERS.....16

1. FUNCTIONS & FEATURES

MODULE	LCD TYPE	REMARK
DEM 128064 SYH-PY	STN Yellow Green Transflective Positive Mode	ROHS

- Viewing Direction : 6 O'clock
- Driving Scheme : 1/64 Duty Cycle, 1/9 Bias
- Power Supply Voltage : 5.0 Volt (typ.)
- Backlight : LED, Lightguide, Yellow Green
- V_{LCD} Adjustable For Best Contrast : 12.9 Volt (typ.)
- Display Format : 128 x 64 Dots
- Interface : 8 bit parallel display data from MPU
- Operating Temperature : -20°C to +70°C
- Storage Temperature : -30°C to +80°C

2. MECHANICAL SPECIFICATIONS

- Module Size : 75.00 x 52.70 x 9.60 mm
- Dot Size : 0.40 x 0.40 mm
- Dot Pitch : 0.43 x 0.43 mm
- Dot Gap : 0.03 mm

3. EXTERNAL DIMENSIONS

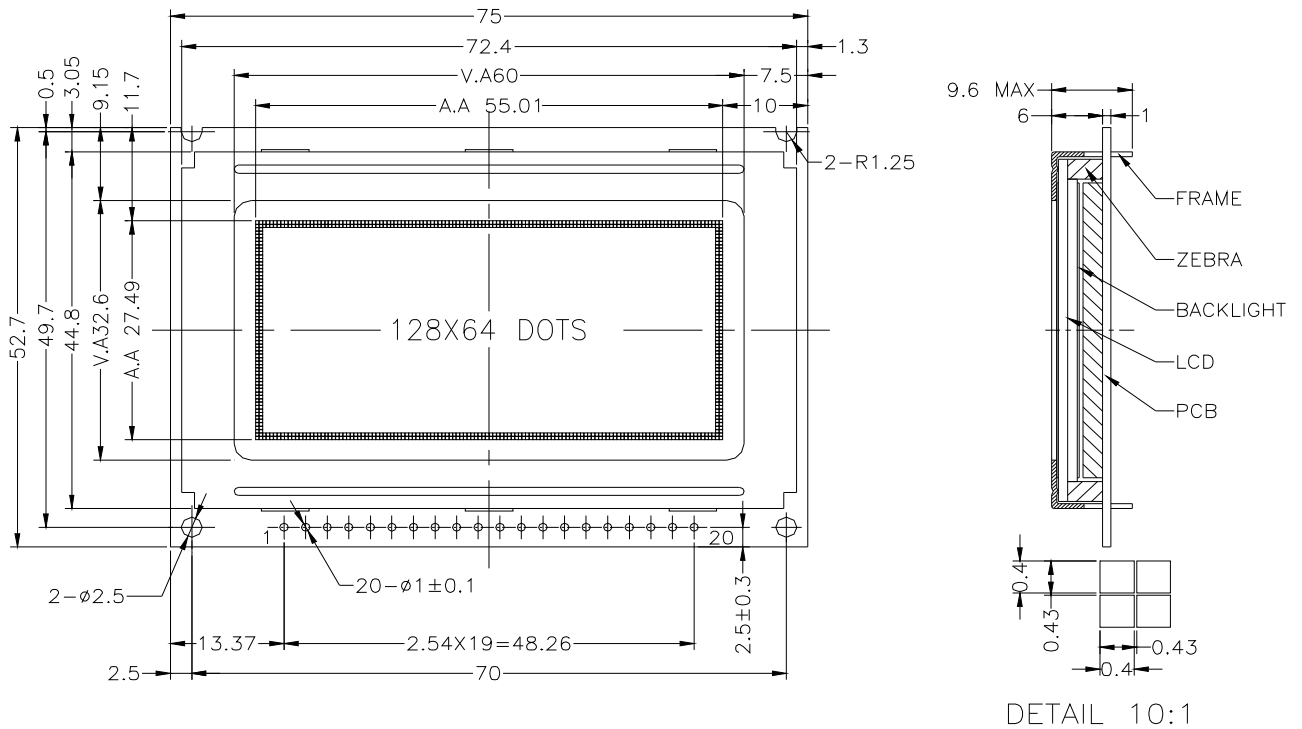

Remarks:

1. Unmarked tolerance is ± 0.3 ,
2. The material comply with RoHS.

4. BLOCK DIAGRAM

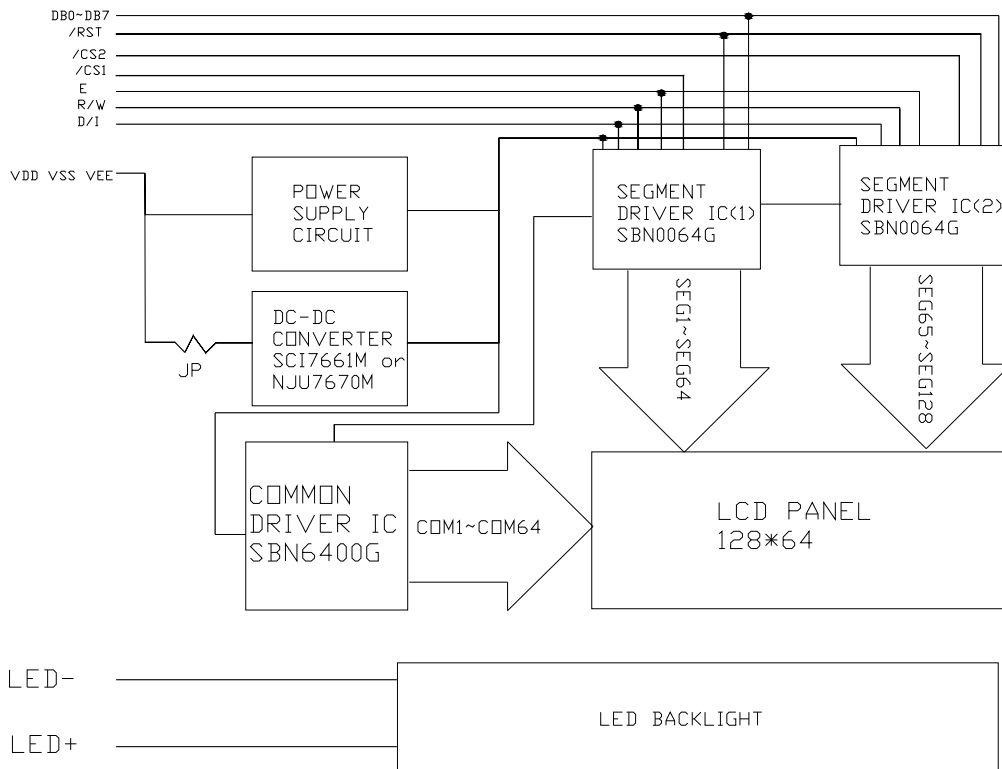

5. PIN ASSIGNMENT

Pin No.	Symbol	Function
1	V _{DD}	POWER SUPPLY FOR LOGIC CIRCUIT
2	V _{SS}	GND
3	V ₀	OPERATING VOLTAGE FOR LCD DRIVING
4	DB0	DATE BUS. Three state I/O port.
5	DB1	
6	DB2	
7	DB3	
8	DB4	
9	DB5	
10	DB6	
11	DB7	
12	CS1	Chip select signal for IC1
13	CS2	Chip select signal for IC2
14	/RST	Reset
15	R/W	H:DATA READ (LCM→MPU) L:DATA WRITE (LCM→MPU)
16	D/I	H:DATA INPUT;L:INSTRUCTION CODE INPUT
17	E	enable
18	VEE	POWER SUPPLY FOR LCD DRIVING
19	LED + (A)	Please refer to 6.1 drawing and description.
20	LED – (K)	

6.1 PCB DRAWING AND DESCRIPTION

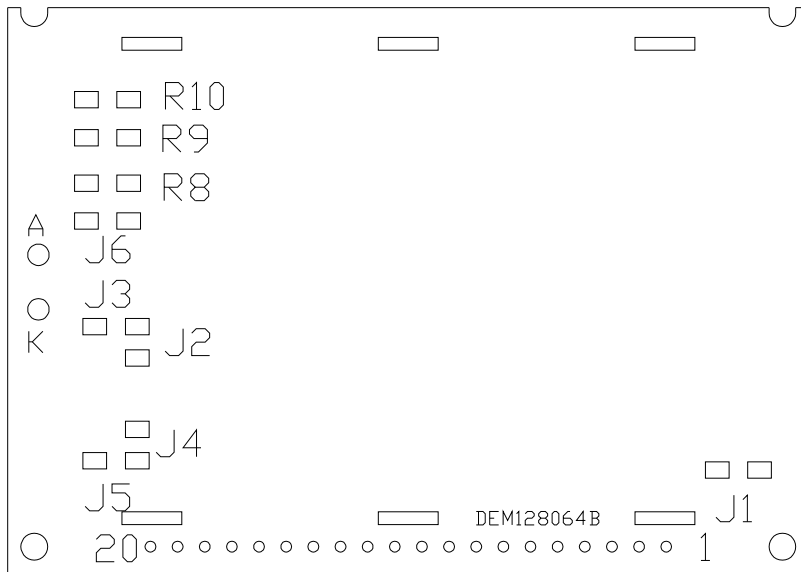

DESCRIPTION:

6-1-1. The polarity of the pin 19 and the pin 20:

J3,J5	J2, J4	LED Polarity	
		19 Pin	20 Pin
Each open	Each close	Anode	Cathode
Each close	Each open	Cathode	Anode

Note: In application module, J3=J5=open, J2=J4=closed

6-1-2. The LED resistor can be bridged when the J6 is closed.

Note: In application module, J6=open

6-1-3. The R8, R9 and R10 are the LED resistor.

Note: In application module, R8=18Ohm, R9=R10=open

6-1-4. The metal-bezel is set on ground when the J1 is closed.

Note: In application module, J1=closed

6.2 Example application

6-2-1. The LED resistor should be bridged as following.

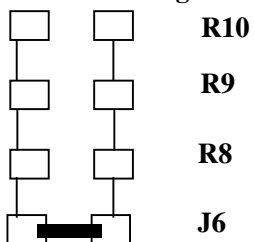

6-2-2. The 19 pin is the anode and the 20 pin is the cathode as following.



6-2-3. The 19 pin is the cathode and the 20 pin is the anode as following.



6-2-4. The metal-bezel is ground as following.



7. Absolute Maximum Ratings (Ta=25°C)

ITEM	SYMBOL	MIN.	TYP.	MAX.	UNIT
OPERATIONG TEMPERATURE	T _{OP}	-20	---	+70	°C
STORAGE TEMPERATURE	T _{ST}	-30	---	+80	°C
INPUT VOLTAGE	V _I	V _{SS}	---	V _{DD}	V
SUPPLY VOLTAGE FOR LOGIC	V _{DD} - V _{SS}	-0.3	---	7.0	V
SUPPLY VOLTAGE FOR LCD	V _{DD} - V ₀	-0.3	---	19.0	V
STATIC ELECTRICITY	Be sure that you are grounded when handling LCM				

8. POWER SUPPLY FOR LCD MODULE

8.1 External Power Supply Circuit

8.2 Internal Power Supply Circuit

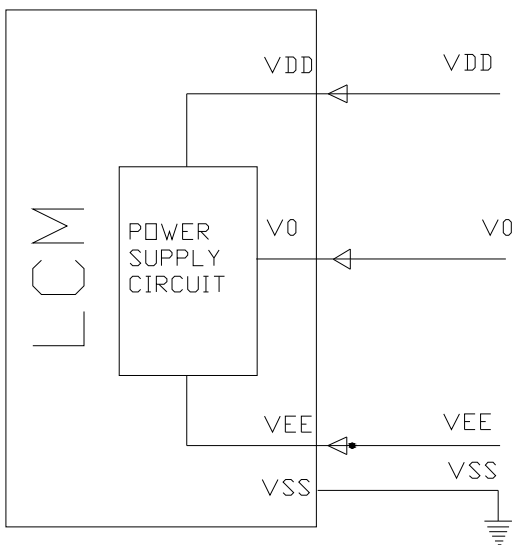

VDD-V0 (V_{LCD}): LCD Driving Voltage

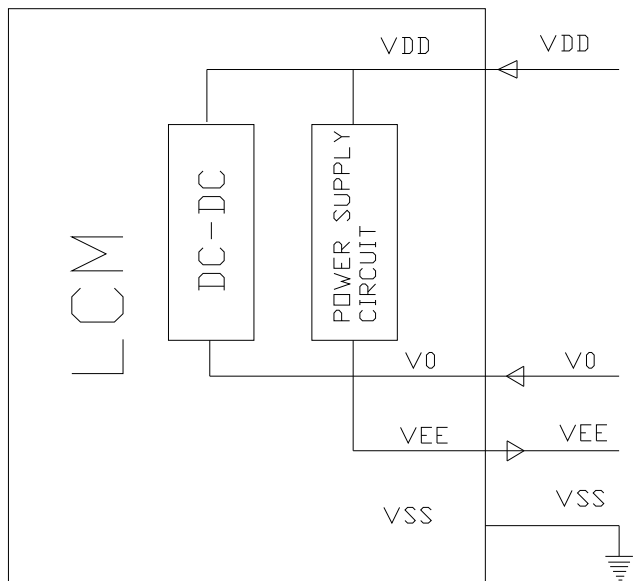

VDD-V0 (V_{LCD}): LCD Driving Voltage

9. ELECTRICAL CHARACTERISTICS

9-1 DC Characteristics ($V_{DD}=+5 \pm 10\% V_{SS}=0V$, $T_a=-20\sim+70^{\circ}C$)

Item	Symbol	Standard Value			Test Condition	Unit
		MIN	TYP	MAX		
Supply Current for Logic	V_{DD}	4.5	5.0	5.5	-----	V
Supply Current for Logic	I_{DD}	----	2.62	4	-----	mA
Operating Voltage for LCD	$V_{DD}-V_0$	13.4	14.1	14.8	-20°C	V
		12.2	12.9	13.6	25°C	
		11.0	11.7	12.4	70°C	
Input Voltage “H” level	V_{IH}	$0.7V_{DD}$	---	V_{DD}	---	V
Input Voltage “L” level	V_{IL}	0	---	$0.3V_{DD}$	---	V

9-2 AC Characteristics

9-2-1. AC timing for writing to the SBN0064G

($V_{DD} = 5\text{ V}$; $V_{SS} = 0\text{ V}$; $T_{amb} = 25^\circ\text{C}$)

symbol	parameter	min.	max.	test conditions	unit
t_{CYC}	Enable (E) cycle time	1000			ns
t_{EWL}	Enable (E) LOW width	450			
t_{EWH}	Enable (E) HIGH width	450			
t_R	Enable (R) rise time		20		
t_F	Enable (F) fall time		20		
t_{AS1}	Write set-up time	140			
t_{AH1}	Write hold time	10			
t_{AS2}	C/D, CS1B, CS2B, CS3 set-up time	140			
t_{AH2}	C/D, CS1B, CS2B, CS3 hold time	10			
t_{DSW}	Data setup time (on the data bus)	200		The loading on the data bus is shown in Fig. 18.	
t_{DHW}	Data hold time (on the data bus)	10			

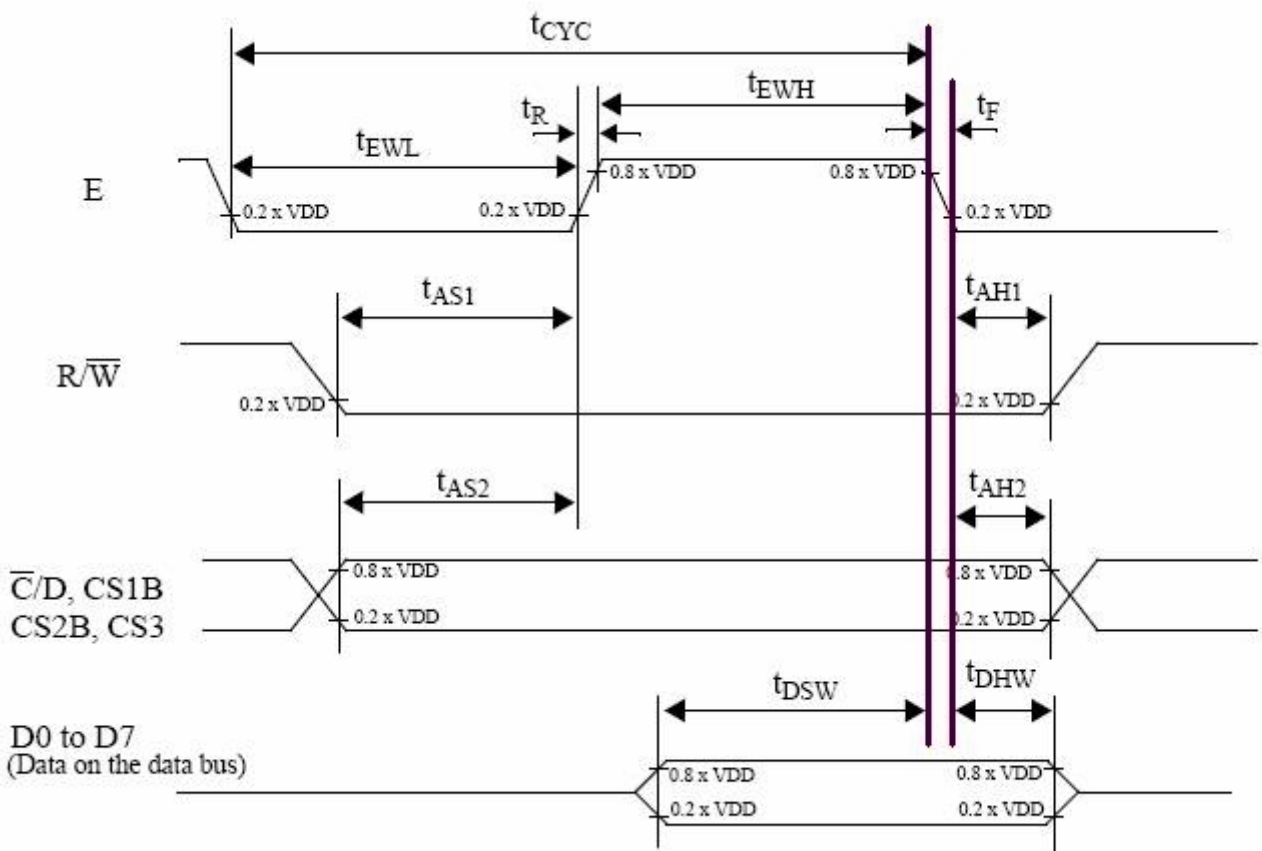

9-2-2. AC timing for reading from the SBN0064G

(VDD = 5 V; VSS = 0 V; Tamb = 25° C.)

symbol	parameter	min.	max.	test conditions	unit
t_{CYC}	Enable (E) cycle time	1000			ns
t_{EWL}	Enable (E) LOW width	450			
t_{EWH}	Enable (E) HIGH width	450			
t_R	Enable (R) rise time		20		
t_F	Enable (F) fall time		20		
t_{AS1}	READ set-up time	140			
t_{AH1}	READ hold time	20			
t_{AS2}	C/D, CS1B, CS2B, CS3 set-up time	140			
t_{AH2}	C/D, CS1B, CS2B, CS3 hold time	10			
t_{DDR}	Data delay time (on the data bus)	320		The loading on the data bus is shown in Fig. 18.	
t_{DHR}	Data hold time (on the data bus)	20			

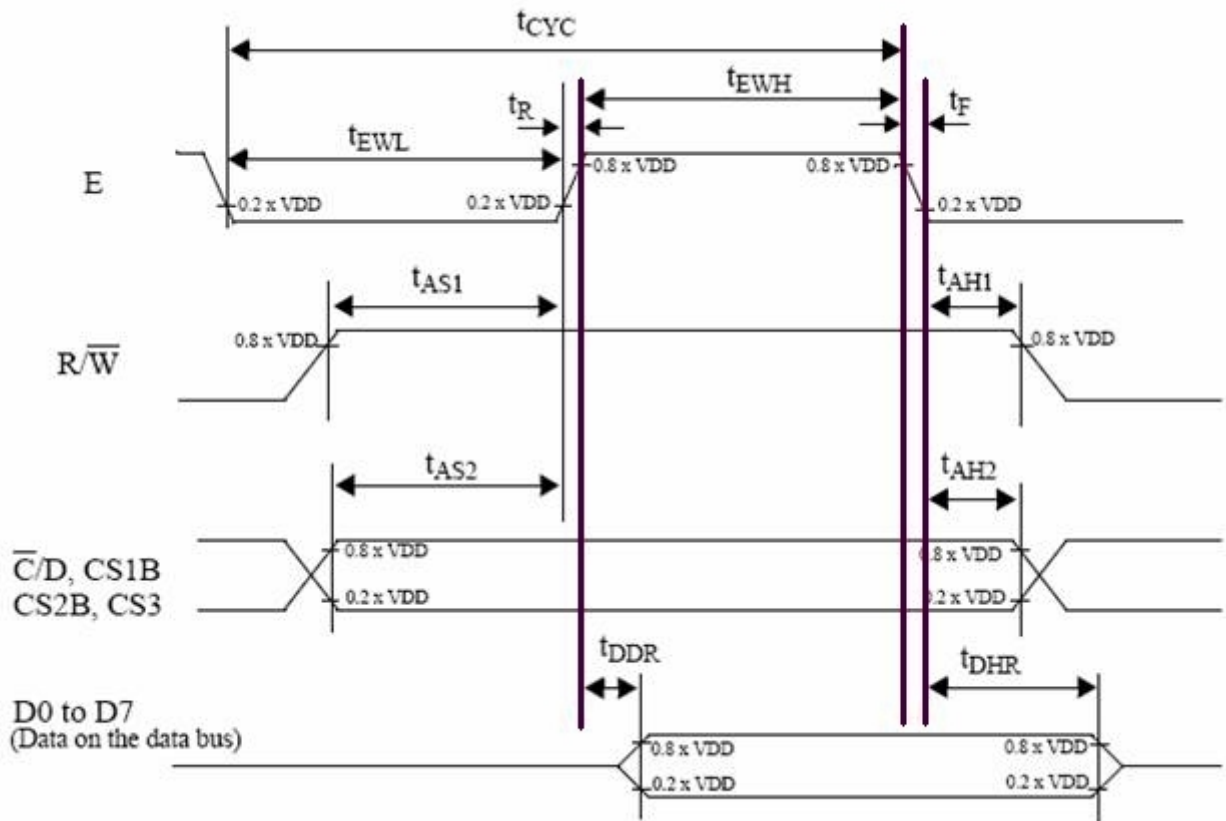

10. DISPLAY CONTROL INSTRUCTION

Registers and their states after hardware RESET

The SBN0064G has 5 registers. Four of them must be programmed by the host microcontroller after hardware reset. The Status Register can be read by the host microcontroller to check the current status of the SBN0064G.

The registers and their states after RESET is given in Table 5.

Table 1 Registers and their states after RESET

Register Name	Description	States after RESET
Display ON/OFF Register	The Display ON/OFF Register is a 1-bit register. After RESET, its value is LOW and, therefore, the LCD display is turned OFF.	0
Display Start Line Register	The Display Start Line Register is a 6-bit register. After RESET, its value is 00 0000 and, therefore, Row 0 of the Display Data Memory is mapped to COM0 of LCD panel.	00 0000
Page Address Register	The Page Address Register is a 3-bit register. It point to a page of the Display Data Memory.	xxx
Column Address Register	The Column Address Register is a 6-bit register.	xx xxxx
Status Register	The Status Register shows the current state of the SBN0064G. It is a 3-bit register, with each bit showing the status of a programmed function.	0010 0000

10-1. Display ON/OFF and the Display ON/OFF Register

Table 2 Setting of the control bus for programming the Display ON/OFF Register

C/D	R/W
0	0

Table 3 Setting of the data bus for programming the Display ON/OFF Register

D7(MSB)	D6	D5	D4	D3	D2	D1	D0(LSB)
0	0	1	1	1	1	1	D0

When D0=1, the code is 3F(Hex) and the display is turned ON. When D0=0, the code is 3E(Hex) and the display is turned OFF.

10-2. Display Start Line and the Display Start Line Register

Table 4 The setting of the control bus for programming the Display Start Line Register

C/D	R/W
0	0

Table 5 The setting of the data bus for programming the Display Start Line Register

D7(MSB)	D6	D5	D4	D3	D2	D1	D0(LSB)
1	1	A5	A4	A3	A2	A1	A0

A5 ~ A0 are Display Start Line address bits and can be programmed with a value in the range from 0 to 63. Therefore, the code can be from 1100 0000 (C0 Hex) to 1111 1111 (FF Hex).

10-3. Display Data Memory Page and the Page Address Register

Table 6 The setting of the control bus for programming the Page Address Register

C/D	R/W
0	0

Table 7 The setting of the data bus for programming the Page Address Register

D7(MSB)	D6	D5	D4	D3	D2	D1	D0(LSB)
1	0	1	1	1	A2	A1	A0

A2, A1 and A0 are page address bits and can be programmed with a value in the range from 0 to 7. A2 A1 A0=000 selects Page 0; A2 A1 A0=001 selects Page 1; A2 A1 A0=010 selects Page 2, and A2 A1 A0=011 selects Page 3...etc. Therefore, the code can be from 1011 1000 (B8 Hex) to 1011 1111 (BF Hex).

10-4. Column address and the Column Address Register

Table 8 The setting of the control bus for programming the Column Address Register

C/D	R/W
0	0

Table 9 The setting of the data bus for programming the Column Address Register

D7(MSB)	D6	D5	D4	D3	D2	D1	D0(LSB)
0	1	A5	A4	A3	A2	A1	A0

A5~A0 are column address bits and can be programmed with a value in the range from 0 to 63. Therefore, the code can be from 0100 0000 (40 Hex) to 0111 1111 (7F Hex).

10-5. Status Read and Status Register

Table 10 The setting of the control bus for reading the Status Register

C/D	R/W
0	1

Table 11 The Status Register bit allocation

D7(MSB)	D6	D5	D4	D3	D2	D1	D0(LSB)
BUSY	0	ON/OFF	RESET	0	0	0	0

Table 12 The Status Register bit description

Bit	Description
BUSY	BUSY=1 indicates that the SBN0064G is currently busy and can not accept new code or data. The SBN0064G is executing an internal operation. BUSY=0 indicates that the SBN0064G is not busy and is ready to accept new code or data.
ON/OFF	The ON/OFF bit indicates the current of status of display. If ON/OFF=0, the display has been turned ON. If ON/OFF=1, the display has been turned OFF. Note that the polarity of this bit is inverse to that of the Display ON/OFF Register.
RESET	RESET=1 indicates that the SBN0064G is currently in the process of being reset. RESET=0 indicates that the SBN0064G is currently in normal operation.

10-6. READ OR WRITE OPERATION TO THE DISPLAY DATA MEMORY

Table 13 READ/WRITE operation

Operation	DATA								Description
	D7	D6	D5	D4	D3	D2	D1	D0	
Write Display Data	Data to be written into the Display Data Memory.								Write a byte of data to the Display Data Memory. The data to be written is put on the data bus by the host microcontroller.
Read Display Data	Data read from the Display Data Memory output latch.								Read a byte of data from the Display Data Memory. The data read from the internal 8-bit output latch (refer to Fig. 12) appears on the data bus. A dummy read is needed to get correct value.

Table 14 The setting of the control bus for Write Display Data operation

C/D	R/W
1	0

Table 15 The setting of the control bus for Read Display Data command

C/D	R/W
1	1

11. BACKLIGHT ELECTRICAL/OPTICAL SPECIFICATIONS

ELECTRICAL–OPTICAL CHARACTERISTICS

(Unless specified, The Ambient temperature $T_a=25^{\circ}\text{C}$)

Item	Symbol	min.	typ.	max.	Unit	Condition
Forward Voltage	V_f	3.6	4.0	4.4	V	If= 60 mA
Peak wave length	λ_p	570	574	578	nm	
Spectral Line Half width	$\Delta\lambda$		30		nm	
Luminance	L_v	35	60		cd/m^2	
Unifromity	Δ	75			%	
Reverse Current	I_r			60	μA	Vr= 3.0 V

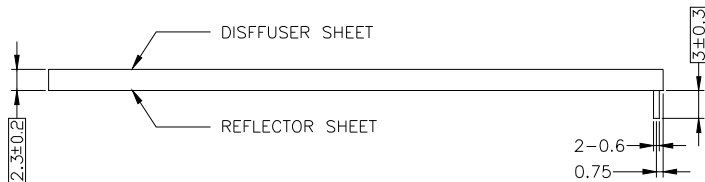
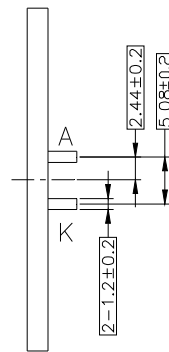
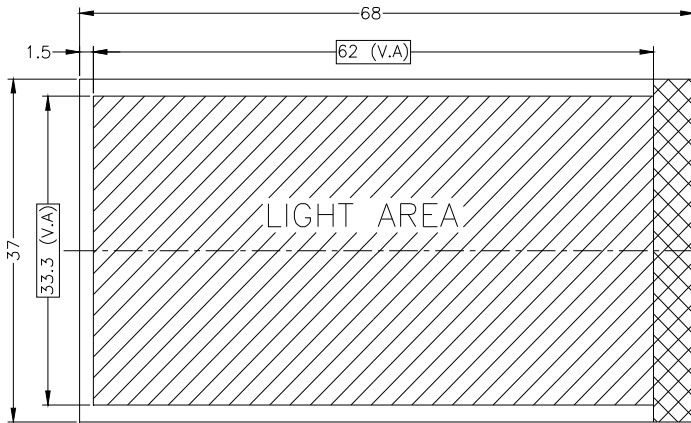

CIRCUIT DIAGRAM (LED 2X4=8 dies)

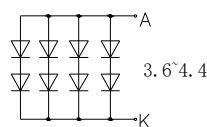

REMARKS:

1. UNMARKED TOLERANCE ± 0.3 ;
2. THE MATERIAL COMPLY WITH ROHS;
3. □: CRITICAL DIMENSION;
4. COLOR: YELLOW-GREEN;
5. THE LIFETIME OF LED: 30000h.

12. LCD MODULES HANDLING PRECAUTIONS

- Please remove the protective foil of polarizer before using.
- The display panel is made of glass. Do not subject it to a mechanical shock by dropping it from a high place, etc.
- If the display panel is damaged and the liquid crystal substance inside it leaks out, do not get any in your mouth. If the substance come into contact with your skin or clothes promptly wash it off using soap and water.
- Do not apply excessive force to the display surface or the adjoining areas since this may cause the color tone to vary.
- The polarizer covering the display surface of the LCD module is soft and easily scratched. Handle this polarize carefully.
- To prevent destruction of the elements by static electricity, be careful to maintain an optimum work environment.
 - Be sure to ground the body when handling the LCD module.
 - Tools required for assembly, such as soldering irons, must be properly grounded.
 - To reduce the amount of static electricity generated, do not conduct assembly and other work under dry conditions.
 - The LCD module is coated with a film to protect the display surface. Exercise care when peeling off this protective film since static electricity may be generated.
- Storage precautions
When storing the LCD modules, avoid exposure to direct sunlight or to the light of fluorescent lamps. Keep the modules in bags designed to prevent static electricity charging under low temperature / normal humidity conditions (avoid high temperature / high humidity and low temperatures below 0°C). Whenever possible, the LCD modules should be stored in the same conditions in which they were shipped from our company.

13. OTHERS

- Liquid crystals solidify at low temperature (below the storage temperature range) leading to defective orientation of liquid crystal or the generation of air bubbles (black or white). Air bubbles may also be generated if the module is subjected to a strong shock at a low temperature.
- If the LCD modules have been operating for a long time showing the same display patterns may remain on the screen as ghost images and a slight contrast irregularity may also appear. Abnormal operating status can be resumed to be normal condition by suspending use for some time. It should be noted that this phenomena does not adversely affect performance reliability.
- To minimize the performance degradation of the LCD modules resulting from caused by static electricity, etc. exercise care to avoid holding the following sections when handling the modules:
 - Exposed area of the printed circuit board
 - Terminal electrode sections