

**DISPLAY Elektronik GmbH**

# DATA SHEET

***TFT MODULE***

**DEM 128160B1 VMH-PW-N**

**1,8“ (with O-Film)**

Product Specification

Ver.: 1

**06.07.2022**

**Revision History**

<b>Revision</b>	<b>Date</b>	<b>Originator</b>	<b>Detail</b>	<b>Remarks</b>
0	05.07.2022		Initial Release	
1	06.07.2022		Update Drawing and package	

**Table of Contents**

No.	Item	Page
1.	General Description .....	4
2.	Module Parameter .....	4
3.	Absolute Maximum Ratings .....	4
4.	DC Characteristics .....	5
5.	Backlight Characteristic .....	5
5.1.	Backlight Characteristic .....	5
5.2.	Backlight Characteristic .....	5
6.	Optical Characteristics .....	6
6.1.	Optical Characteristics .....	6
6.2.	Definition of Response Time .....	6
6.3.	Definition of Contrast Ratio .....	7
6.4.	Definition of Viewing Angles .....	7
6.5.	Definition of Color Appearance .....	8
6.6.	Definition of Surface Luminance, Uniformity and Transmittance .....	8
7.	Block Diagram and Power Supply .....	9
8.	Interface Pins Definition .....	10
9.	AC Characteristics .....	11
9.1.	Reset timing .....	11
9.2.	Interface timing .....	12
10.	Command Table .....	14
11.	Quality Assurance .....	21
11.1.	Purpose .....	21
11.2.	Standard for Quality Test .....	21
11.3.	Nonconforming Analysis & Disposition .....	21
11.4.	Agreement Items .....	21
11.5.	Standard of the Product Visual Inspection .....	21
11.6.	Inspection Specification .....	22
11.7.	Classification of Defects .....	26
11.8.	Identification/marketing criteria .....	26
11.9.	Packaging .....	26
12.	Reliability Specification .....	27
13.	Precautions and Warranty .....	28
13.1	Safety .....	28
13.2.	Handling .....	28
13.3.	Storage .....	28
13.4.	Metal Pin (Apply to Products with Metal Pins) .....	28
13.5.	Operation .....	29
13.6.	Static Electricity .....	29
13.7.	Limited Warranty .....	29
14.	Outline Drawing .....	30

## 1. General Description

The specification is a transmissive type color active matrix liquid crystal display (LCD) which uses amorphous thin film transistor (TFT) as switching devices. This product is composed of a TFT-LCD panel, driver ICs and a backlight unit.

## 2. Module Parameter

Features	Details	Unit
Display Size (Diagonal)	1.77"	-
LCD type	TN TFT (with O-Film)	-
Display Mode	Transmissive /Normally white	-
Resolution	128 x RGB x 160	Pixels
View Direction	Free View (O-Film)	Best Image
Gray Scale Inversion Direction	12 O'clock	-
Module Outline	34.70 x 46.75 x 2.25 (Note1 )	mm
Active Area	28.03 x 35.04	mm
Pixel Size	0.2190 x 0.2190	mm
Pixel Arrangement	Stripe	-
Polarizer Surface Treatment	Anti-glare	-
Display Colors	262K	-
Interface	MCU 8bit	-
With or without touch panel	Without	-
Driver IC	ILI9163V	-
Operating Temperature	-20~70	°C
Storage Temperature	-30~80	°C
Weight	5	g

Note 1: Exclusive hooks, posts, FFC/FPC tail etc.

## 3. Absolute Maximum Ratings

V<sub>SS</sub>=0V, Ta=25°C

Item	Symbol	Min.	Max.	Unit	
Supply Voltage	Logic	IOVCC	-0.3	4.6	V
	Analog	VCC	-0.3	4.6	V
Storage Temperature	T <sub>STG</sub>	-30	+80	°C	
Operating Temperature	T <sub>OP</sub>	-20	+70	°C	

Note 1: If Ta below 50°C, the maximal humidity is 90%RH, if Ta over 50°C, absolute humidity should be less than 60%RH.

Note 2: The response time will be extremely slow when the operating temperature is around -10°C, and the back ground will become darker at high temperature operating.

**4. DC Characteristics**

Item		Symbol	Min.	Typ.	Max.	Unit
Supply Voltage	Logic	IOVCC	1.65	2.8	3.3	V
	Analog	VCC	2.5	2.8	3.3	V
Logic Low Input Voltage		V <sub>IL</sub>	GND	-	0.3*IOVCC	V
Logic High Input Voltage		V <sub>IH</sub>	0.7*IOVCC	-	IOVCC	V
Logic Low Output Voltage		V <sub>OL</sub>	GND	-	0.2*IOVCC	V
Logic High Output Voltage		V <sub>OH</sub>	0.8*IOVCC	-	IOVCC	V
Current Consumption All Black	Logic	I <sub>CC+ I<sub>IN</sub></sub>	-	5	10	mA
	Analog					

**5. Backlight Characteristic**

**5.1. Backlight Characteristic**

Item	Symbol	Condition	Min.	Typ.	Max.	Unit
Forward Voltage	V <sub>F</sub>	T <sub>a</sub> =25 °C, I <sub>F</sub> =20mA/LED	2.8	3.1	3.4	V
Forward Current	I <sub>F</sub>	T <sub>a</sub> =25 °C, V <sub>F</sub> =3.1V/LED	-	40	50	mA
Power Dissipation	P <sub>D</sub>		-	93	136	mW
Uniformity	Avg		80	-	-	%
LED Lifetime (25°C)	-		-	30,000	-	Hrs
Drive Method	Constant Current					
LED Configuration	2 White LEDs in parallel					

Note1: LED life time defined as follows: The final brightness is at 50% of original brightness.

The environmental conducted under ambient air flow, at T<sub>a</sub>=25°C±2°C, 60%RH±5%, I<sub>F</sub>=20mA

**5.2. Backlight Characteristic**

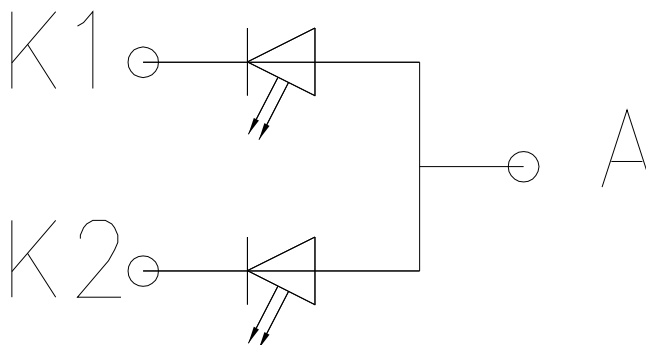

Backlight

6. Optical Characteristics

6.1. Optical Characteristics

Ta=25°C, VCC=2.8V

	Item	Symbol	Condition	Specification			Unit	
				Min.	Typ.	Max.		
Backlight On (Transmissive Mode)	Luminance on TFT( $I_f=20\text{mA/LED}$ )	Lv	Normally viewing angle $\theta_X = \phi_Y = 0^\circ$	320	400	-	cd/m <sup>2</sup>	
	Contrast Ratio(See 6.3)	CR		400	500	-		
	Response Time (See 6.2)	TR+TF		-	8	16	ms	
	Chromaticity Transmissive (See 6.5)	White		Xw	0.245	0.295	0.345	
				Yw	.0274	0.324	0.374	
	Viewing Angle (See 6.4)	Horizontal	$\theta_{X+}$	50	70	-	Deg.	
			$\theta_{X-}$	50	70	-		
		Vertical	$\phi_{Y+}$	50	70	-		
			$\phi_{Y-}$	30	70	-		
	NTSC Ratio(Gamut)			-	60	-	%	

6.2. Definition of Response Time

6.2.1. Normally Black Type (Negative)

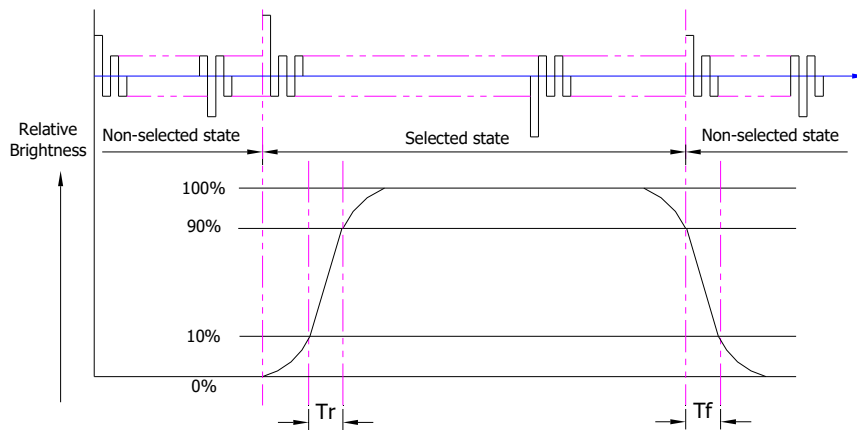

Tr is the time it takes to change from non-selected stage with relative luminance 10% to selected state with relative luminance 90%;

Tf is the time it takes to change from selected state with relative luminance 90% to non-selected state with relative luminance 10%.

Note: Measuring machine: LCD-5100

**6.2.2. Normally White Type (Positive)**

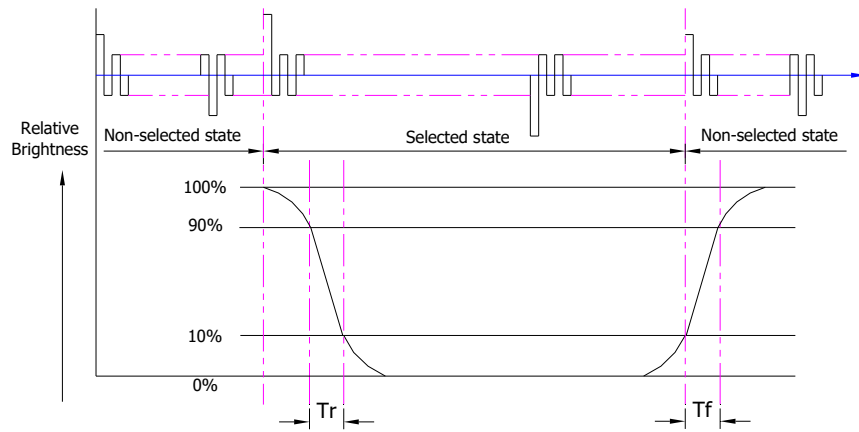

$T_r$  is the time it takes to change from non-selected stage with relative luminance 90% to selected state with relative luminance 10%;

$T_f$  is the time it takes to change from selected state with relative luminance 10% to non-selected state with relative luminance 90%;

Note: Measuring machine: LCD-5100 or EQUI

**6.3. Definition of Contrast Ratio**

Contrast is measured perpendicular to display surface in reflective and transmissive mode.

The measurement condition is:

Measuring Equipment	Eldim or Equivalent
Measuring Point Diameter	3mm//1mm
Measuring Point Location	Active Area centre point
Test pattern	A: All Pixels white
	B: All Pixel black
Contrast setting	Maximum

Definitions: CR (Contrast) = Luminance of White Pixel / Luminance of Black Pixel

**6.4. Definition of Viewing Angles**

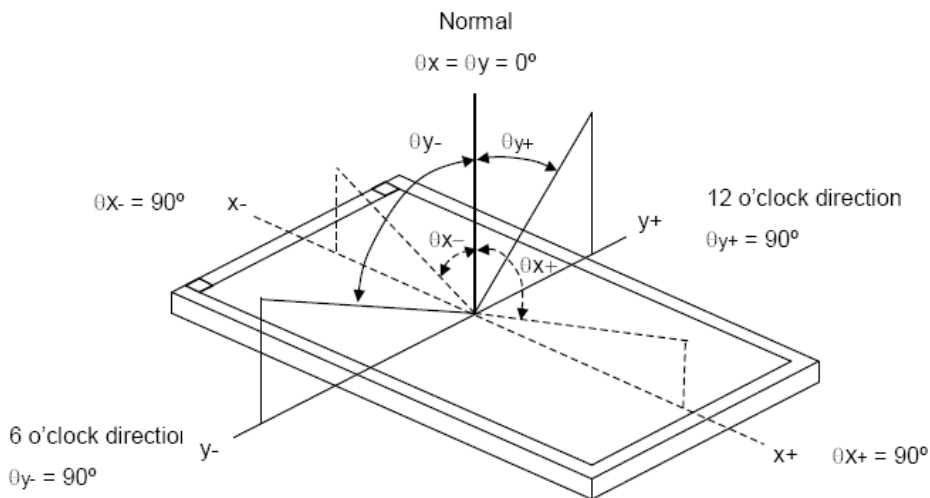

Measuring machine: LCD-5100 or EQUI

**6.5. Definition of Color Appearance**

R,G,B and W are defined by (x, y) on the IE chromaticity diagram

NTSC=area of RGB triangle/area of NTSC triangleX100%

Measuring picture: Red, Green, Blue and White (Measuring machine: BM-7)

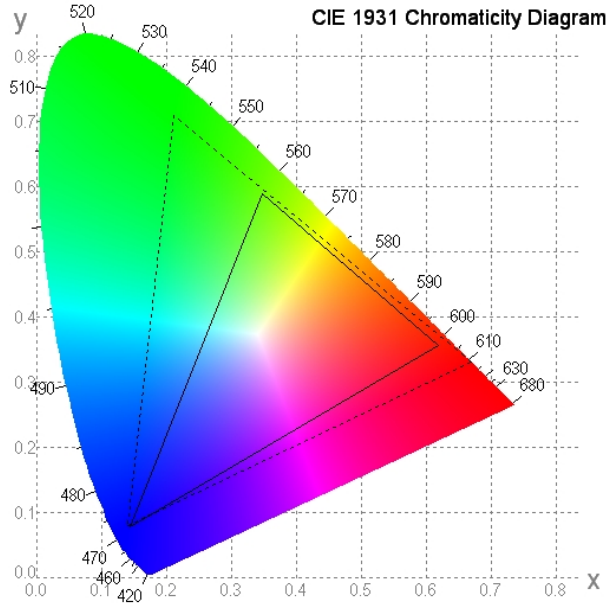

**6.6. Definition of Surface Luminance, Uniformity and Transmittance**

Using the transmissive mode measurement approach, measure the white screen luminance of the display panel and backlight.

6.6.1. Surface Luminance:  $L_v = \text{average} (L_{P1}:L_{P9})$

6.6.2. Uniformity =  $\text{Minimal} (L_{P1}:L_{P9}) / \text{Maximal} (L_{P1}:L_{P9}) * 100\%$

6.6.3. Transmittance =  $L_v \text{ on LCD} / L_v \text{ on Backlight} * 100\%$

Note: Measuring machine: BM-7

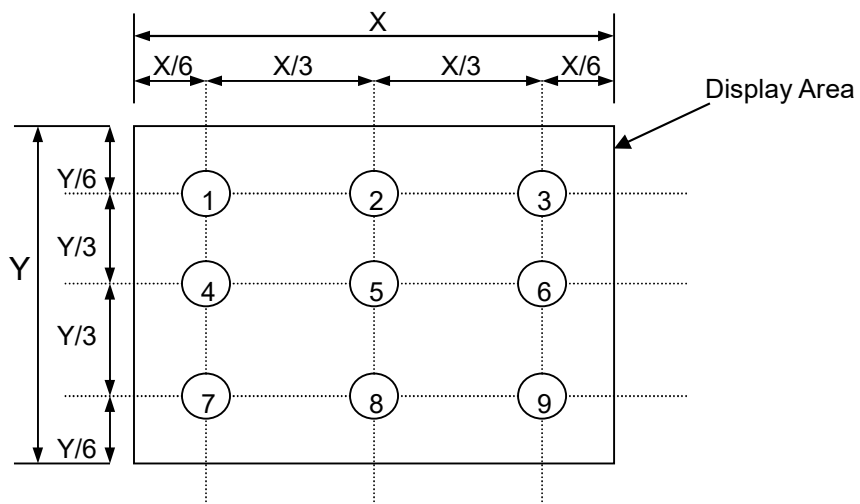



7. Block Diagram and Power Supply

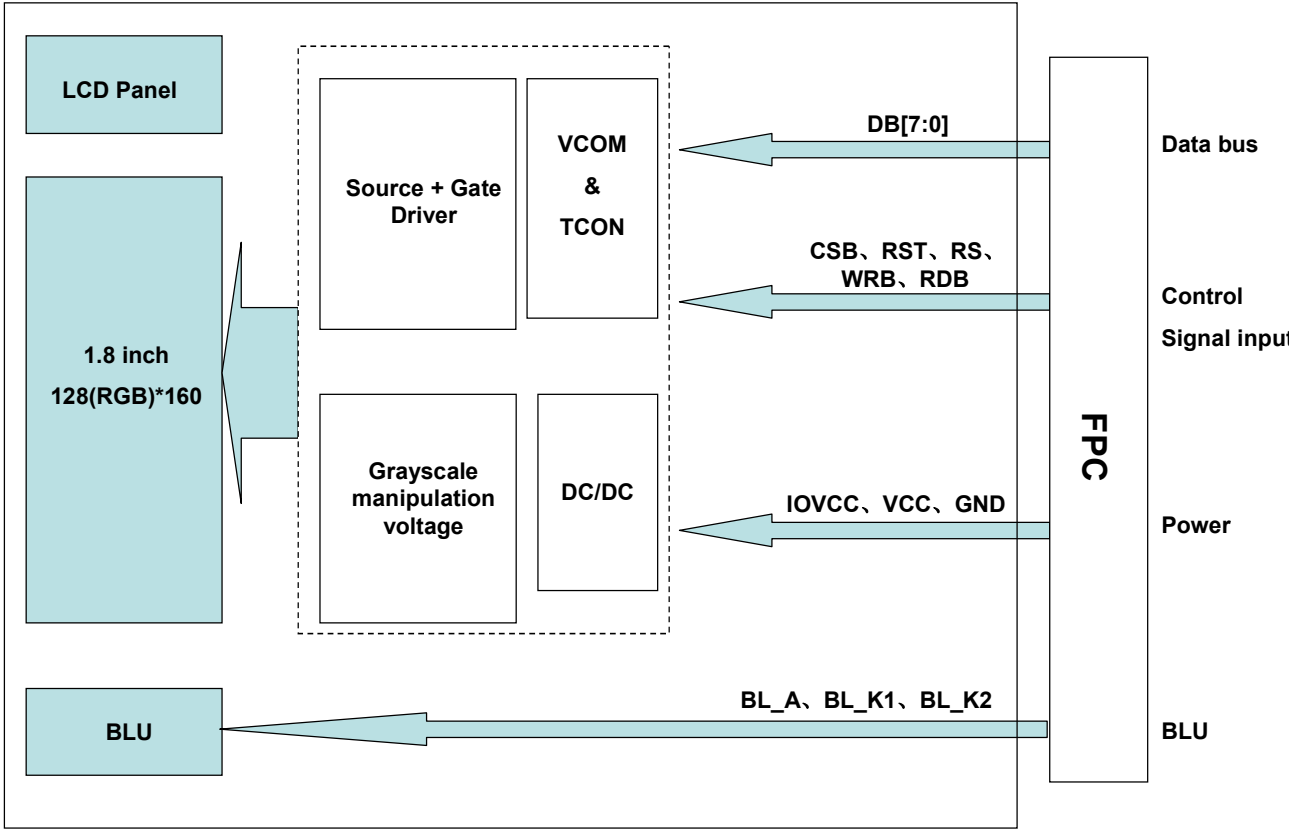

**8. Interface Pins Definition**

No.	Symbol	Function	Remark
1	GND	Ground	
2	IOVCC	Logic Power(1.8V)	
3	VCC	Analog Power(2.8V)	
4	CSB	Chip Select Signal	
5	RST	Reset Signal	
6	RS	Data/Command Signal	
7	WRB	Write signal	
8	RDB	Read signal	
9	DB0	Data bus	
10	DB1	Data bus	
11	DB2	Data bus	
12	DB3	Data bus	
13	DB4	Data bus	
14	DB5	Data bus	
15	DB6	Data bus	
16	DB7	Data bus	
17	BL_A	Led anode	
18	BL_K1	Led cathode	
19	BL_K2	Led cathode	
20	GND	Ground	

9. AC Characteristics

9.1. Reset timing

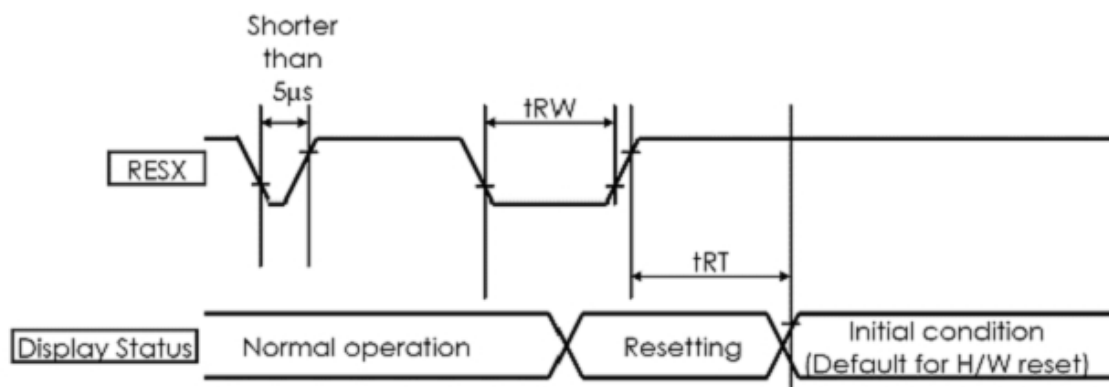

(VSS=0V, VDDI=1.65V to 1.95V, VPNL=2.6V to 2.9V, Ta = -30 to 70°C)

Symbol	Parameter	Related Pins	MIN	TYP	MAX	Note	Unit
tRESW	*1) Reset low pulse width	RESX	10	-	-	-	µs
tREST	*2) Reset complete width	-	-	-	5	When reset applied during Sleep in mode	ms
		-	-	-	120	When reset applied during Sleep out mode	ms

Note

1. Spike due to an electrostatic discharge on RESX line does not cause system reset according to the table below.

9.2. Interface timing

Display Module Parallel 18/16/9/8-bit Bus

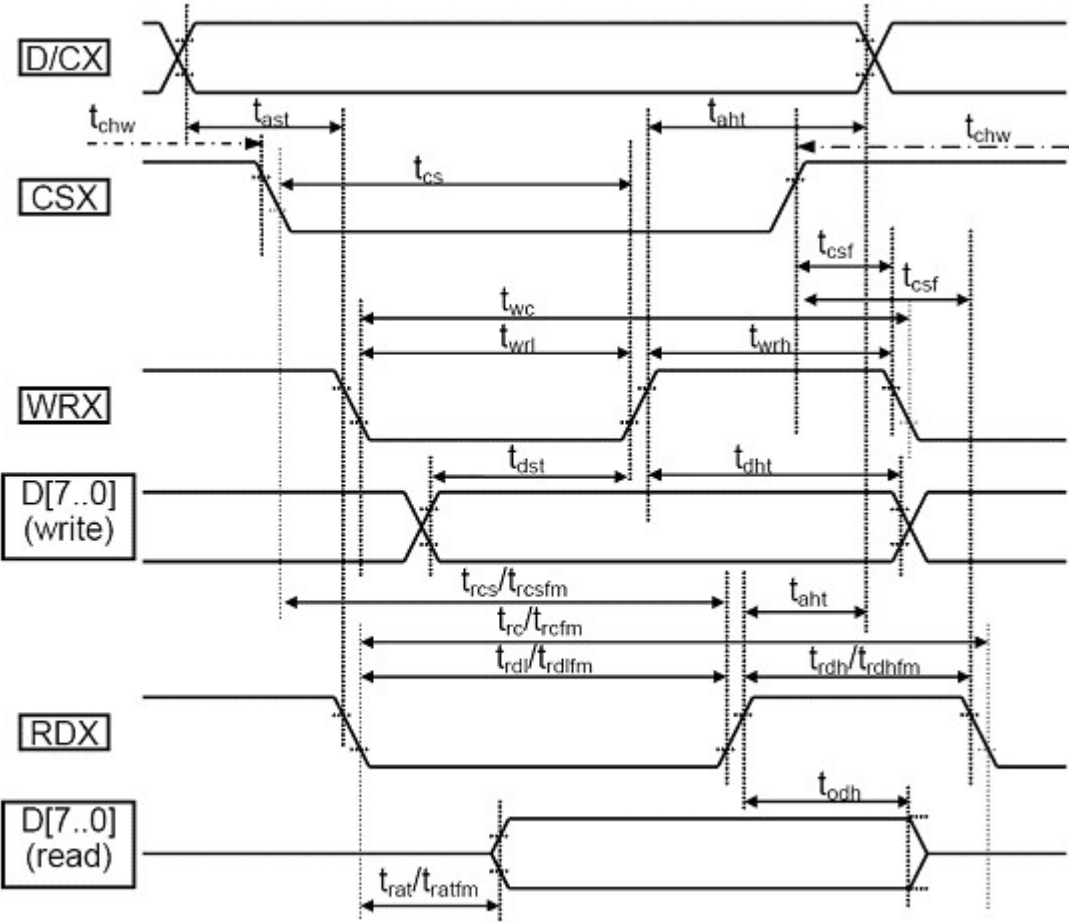

Note: Logic high and low levels are specified as 30% and 70% of VDDI for Input signals.

Signal	Symbol	Parameter	min	max	unit	description
D/CX	tast	Address setup time	0		ns	
	taht	Address hold time(Write/Read)	10		ns	
CSX	tchw	"S""H" Pulse Width	0		ns	
	tcs	Chip Select setup time (Write)	10		ns	
	trcs	Chip Select setup time (Read ID)	45		ns	
	trcsfm	Chip Select setup time (Read FM)	355		ns	
	tcsf	Chip Select Wait time(Write/read)	10		ns	

WRX	twc	Write cycle	66		ns	
	twrh	Control pulse H duration	15		ns	
	twrl	Control pulse L duration	15		ns	
RDX	trc	Read cycle (ID)	160		ns	When read ID data
	trdh	Control pulse H duration(ID)	90		ns	
	trdl	Control pulse L duration(ID)	45		ns	
RDX	trcfm	Read cycle (FM)	450		ns	When read from frame memory
	trdhfm	Control pulse H duration (FM)	90		ns	
	trdlfm	Control pulse L duration (FM)	355		ns	
D[17..0]	tdst	Data setup time	10		ns	For maximum CL = 30pF
	tdht	Data hold time	10		ns	
	trat	Read access time (ID)		40	ns	For minimum CL = 8pF
	trafm	Read access time (FM)		340	ns	
	todh	Output disable time	20	80	ns	

Note 1: VDDI 1.65 to 3.3V, VDD=2.6 to 3.3V, AGND=GND=0V, Ta=-30 to 70 °C (to +85°C no damage)

Note 2: This input signal rise time and fall time (tr, tf) is specified at 15 ns or less. Logic high and low levels are specified as 30% and 70% of VDDI for input signals

10. Command Table

Code	Command	D17-8	D7	D6	D5	D4	D3	D2	D1	D0	Hex	Ref.
00H	NOP (No Operation)	X	0	0	0	0	0	0	0	0	00h	
01H	Software Reset	X	0	0	0	0	0	0	0	1	01h	
04H	Read Display Identification Information	X	0	0	0	0	0	1	0	0	04h	
	1 <sup>st</sup> Parameter	X	X	X	X	X	X	X	X	X	X	
	2 <sup>nd</sup> Parameter	X	ID17	ID16	ID15	ID14	ID13	ID12	ID11	ID10	54h	
	3 <sup>rd</sup> Parameter	X	ID27	ID26	ID25	ID24	ID23	ID22	ID21	ID20	80h	
	4 <sup>th</sup> Parameter	X	ID37	ID36	ID35	ID34	ID33	ID32	ID31	ID30	66h	
09H	Read Display Status	X	0	0	0	0	1	0	0	1	09h	
	1 <sup>st</sup> Parameter	X	X	X	X	X	X	X	X	X	X	
	2 <sup>nd</sup> Parameter	X	BSTON	MY	MX	MV	ML	RGB	MH	ST24	00h	
	3 <sup>rd</sup> Parameter	X	ST23	IFFF2	IFFF1	IFFF0	IDMON	PTLON	SLOUT	NORON	61h	
	4 <sup>th</sup> Parameter	X	V83ON	ST14	INVON	ST12	ST11	DISON	TEON	GCS2	00h	
	5 <sup>th</sup> Parameter	X	GCS1	GCS0	TELOM	HSON	VSON	PCKON	DEON	ST0	00h	
0AH	Read Display Power Mode	X	0	0	0	0	1	0	1	0	0Ah	
	1 <sup>st</sup> Parameter	X	X	X	X	X	X	X	X	X	X	
	2 <sup>nd</sup> Parameter	X	BSTON	IDMON	PLTON	SLPOUT	NORON	DISON	D1	D0	08h	
0BH	Read Display MADCTL	X	0	0	0	0	1	0	1	1	0Bh	
	1 <sup>st</sup> Parameter	X	X	X	X	X	X	X	X	X	X	
	2 <sup>nd</sup> Parameter	X	MY	MX	MV	ML	RGB	MH	D1	D0	00h	
0CH	Read Display Pixel Format	X	0	0	0	0	1	1	0	0	0Ch	
	1 <sup>st</sup> Parameter	X	X	X	X	X	X	X	X	X	X	
	2 <sup>nd</sup> Parameter	X	VIPF3	VIPF2	VIPF1	VIPF0	D3	IFFF2	IFFF1	IFFF0	06h	
0DH	Read Display Image Mode	X	0	0	0	0	1	1	0	1	0Dh	
	1 <sup>st</sup> Parameter	X	X	X	X	X	X	X	X	X	X	
	2 <sup>nd</sup> Parameter	X	V83ON	D6	INVON	D4	D3	GCS2	GCS1	GCS0	00h	
0EH	Read Display Signal Mode	x	0	0	0	0	1	1	1	0	0Eh	
	1 <sup>st</sup> Parameter	x	x	x	x	x	x	x	x	x	x	
	2 <sup>nd</sup> Parameter	x	D7	D6	HSON	VSON	PCKON	DEON	D1	D0	00h	
0FH	Read Display Signal Mode	x	0	0	0	0	1	1	1	1	0Fh	
	1 <sup>st</sup> Parameter	x	X	x	x	x	x	x	x	x	x	
	2 <sup>nd</sup> Parameter	x	RELD	FUND	D5	D4	D3	D2	D1	D0	00h	

10H	Sleep In	x	0	0	0	1	0	0	0	0	10h
11H	Sleep Out	x	0	0	0	1	0	0	0	1	11h
12H	Partial Mode On	x	0	0	0	1	0	0	1	0	12h
13H	Normal Display Mode On	x	0	0	0	1	0	0	1	1	13h
20H	Display Inversion Off	x	0	0	1	0	0	0	0	0	20h
21H	Display Inversion On	x	0	0	1	0	0	0	0	1	21h
26H	Gamma Set	x	0	0	1	0	0	1	1	0	26h
	1 <sup>st</sup> Parameter	x	GC7	GC6	GC5	GC4	GC3	GC2	GC1	GC0	01h
28H	Display Off	x	0	0	1	0	1	0	0	0	28h
29H	Display On	x	0	0	1	0	1	0	0	1	29h
2AH	Column Address Set	x	0	0	1	0	1	0	1	0	2Ah
	1 <sup>st</sup> Parameter	x	XS15	XS14	XS13	XS12	XS11	XS10	XS9	XS8	-
	2 <sup>nd</sup> Parameter	x	XS7	XS6	XS5	XS4	XS3	XS2	XS1	XS0	-
	3 <sup>rd</sup> Parameter	x	XE15	XE14	XE13	XE12	XE11	XE10	XE9	XE8	-
	4 <sup>th</sup> Parameter	x	XE7	XE6	XE5	XE4	XE3	XE2	XE1	XE0	-
2BH	Page Address Set	x	0	0	1	0	1	0	1	1	2Bh
	1 <sup>st</sup> Parameter	x	YS15	YS14	YS13	YS12	YS11	YS10	YS9	YS8	-
	2 <sup>nd</sup> Parameter	x	YS7	YS6	YS5	YS4	YS3	YS2	YS1	YS0	-
	3 <sup>rd</sup> Parameter	x	YE15	YE14	YE13	YE12	YE11	YE10	YE9	YE8	-
	4 <sup>th</sup> Parameter	x	YE7	YE6	YE5	YE4	YE3	YE2	YE1	YE0	-
2CH	Memory Write	x	0	0	1	0	1	1	0	0	2Ch
	1 <sup>st</sup> Parameter	D17-8	D7	D6	D5	D4	D3	D2	D1	D0	-
	:	x	:	:	:	:	:	:	:	:	-
	N <sup>th</sup> Parameter	D17-8	D7	D6	D5	D4	D3	D2	D1	D0	-
2DH	Color Setting for 4K, 65K and 262K	x	0	0	1	0	1	1	0	1	2Dh
	1 <sup>st</sup> Parameter	x	x	x	R005	R004	R003	R002	R001	R000	-
	:	x	x	x	Rnn5	Rnn4	Rnn3	Rnn2	Rnn1	Rnn0	-
	32 <sup>nd</sup> parameter	x	x	x	R315	R314	R313	R312	R311	R310	-
	33 <sup>rd</sup> Parameter	x	x	x	G005	G004	G003	G002	G001	G000	-
	:	x	x	x	Gnn5	Gnn4	Gnn3	Gnn2	Gnn1	Gnn0	-
	96 <sup>th</sup> Parameter	x	x	x	G635	G634	G633	G632	G631	G630	-
	97 <sup>th</sup> Parameter	x	x	x	B005	B004	B003	B002	B001	B000	-
	:	x	x	x	Bnn5	Bnn4	Bnn3	Bnn2	Bnn1	Bnn0	-
	128 <sup>th</sup> Parameter	x	x	x	B315	B314	B313	B312	B311	B310	-

2EH	Memory Read	x	0	0	1	0	1	1	1	0	2Eh
	1 <sup>st</sup> Parameter	x	x	x	x	x	x	x	x	x	-
	2 <sup>nd</sup> Parameter	x	D17	D16	D15	D14	D13	D12	D11	D10	-
	:	x	:	:	:	:	:	:	:	:	-
	N <sup>th</sup> Parameter	x	Dn7	Dn6	Dn5	Dn4	Dn3	Dn2	Dn1	Dn0	-
30H	Partial Area	x	0	0	1	1	0	0	0	0	30h
	1 <sup>st</sup> Parameter	x	PSL15	PSL14	PSL13	PSL12	PSL11	PSL10	PSL9	PSL8	-
	2 <sup>nd</sup> Parameter	x	PSL7	PSL6	PSL5	PSL4	PSL3	PSL2	PSL1	PSL0	-
	3 <sup>rd</sup> Parameter	x	PEL15	PEL14	PEL13	PEL12	PEL11	PEL10	PEL9	PEL8	-
	4 <sup>th</sup> Parameter	x	PEL7	PEL6	PEL5	PEL4	PEL3	PEL2	PEL1	PEL0	-
33H	Vertical Scrolling Definition	x	0	0	1	1	0	0	1	1	33h
	1 <sup>st</sup> Parameter	x	TFA15	TFA14	TFA13	TFA12	TFA11	TFA10	TFA9	TFA8	-
	2 <sup>nd</sup> Parameter	x	TFA7	TFA6	TFA5	TFA4	TFA3	TFA2	TFA1	TFA0	-
	3 <sup>rd</sup> Parameter	x	VSA15	VSA14	VSA13	VSA12	VSA11	VSA10	VSA9	VSA8	-
	4 <sup>th</sup> Parameter	x	VSA7	VSA6	VSA5	VSA4	VSA3	VSA2	VSA1	VSA0	-
	5 <sup>th</sup> Parameter	x	BFA15	BFA14	BFA13	BFA12	BFA11	BFA10	BFA9	BFA8	-
	6 <sup>th</sup> Parameter	x	BFA7	BFA6	BFA5	BFA4	BFA3	BFA2	BFA1	BFA0	-
34H	Tearing Effect Line Off	x	0	0	1	1	0	1	0	0	34h
35H	Tearing Effect Line On	x	0	0	1	1	0	1	0	1	35h
	1 <sup>st</sup> Parameter	x	x	x	x	x	x	x	x	M	00h
36H	Memory Access Control	x	0	0	1	1	0	1	1	0	36h
	1 <sup>st</sup> Parameter	x	MY	MX	MV	ML	RGB	MH	x	x	00h
37H	Vertical Scrolling Start Address	x	0	0	1	1	0	1	1	1	37h
	1 <sup>st</sup> Parameter	x	SSA 15	SSA 14	SSA 13	SSA 12	SSA 11	SSA 10	SSA 9	SSA 8	00h
	2 <sup>nd</sup> Parameter	x	SSA 7	SSA 6	SSA 5	SSA 4	SSA 3	SSA 2	SSA 1	SSA 0	00h
38H	Idle Mode Off	x	0	0	1	1	1	0	0	0	38h
39H	Idle Mode On	x	0	0	1	1	1	0	0	1	39h
3AH	Interface Pixel Format	x	0	0	1	1	1	0	1	0	3Ah
	1 <sup>st</sup> Parameter	x	VIPF3	VIPF2	VIPF1	VIPF0	D3	IFPF2	IFPF1	IFPF0	66h



B1H	Frame Rate Control (In normal mode/Full colors)		1	0	1	1	0	0	0	1	B1h
	1 <sup>st</sup> Parameter		x	x	x	DIVA4	DIVA3	DIVA2	DIVA1	DIVA0	x
	2 <sup>nd</sup> Parameter		x	x	VPA5	VPA4	VPA3	VPA2	VPA1	VPA0	x
B2H	Frame Rate Control(In Idle mode/8-colors)		1	0	1	1	0	0	1	0	B2h
	1 <sup>st</sup> Parameter		x	x	x	DIVB4	DIVB3	DIVB2	DIVB1	DIVB0	x
	2 <sup>nd</sup> Parameter		x	x	VPB5	VPB4	VPB3	VPB2	VPB1	VPB0	x
B3H	Frame Rate Control(In Partial mode/full colors)		1	0	1	1	0	0	1	1	B3h
	1 <sup>st</sup> Parameter		x	x	x	DIVC4	DIVC3	DIVC2	DIVC1	DIVC0	x
	2 <sup>nd</sup> Parameter		x	x	VPC5	VPC4	VPC3	VPC2	VPC1	VPC0	x
B4H	Display Inversion Control	x	1	0	1	1	0	1	0	0	B4h
	1 <sup>st</sup> Parameter	x	0	0	0	0	0	NLA	NLB	NLC	02H
B5H	RGB Interface Blanking Porch setting	x	1	0	1	1	0	1	0	1	B5h
	1 <sup>st</sup> Parameter	x	x	x	HBP5	HBP4	HBP3	HBP2	HBP1	HBP0	08h
	2 <sup>nd</sup> Parameter	x	VBP7	VBP6	VBP5	VBP4	VBP3	VBP2	VBP1	VBP0	03h
	3 <sup>rd</sup> Parameter	x	x	x	x	x	x	x	VBP9	VBP8	00h
B6H	Display Function Set	x	1	0	1	1	0	1	1	0	B6h
	1 <sup>st</sup> Parameter		x	x	NO1	NO0	SDT1	SDT0	EQ1	EQ2	08h
	2 <sup>nd</sup> Parameter		x	x	x	x	x	PTG0	PT1	PT0	02h
B7H	Source Driver Direction Control	x	1	0	1	1	0	1	1	1	B7h
	1 <sup>st</sup> Parameter	x	0	0	0	0	0	0	0	CRL	00h

B8H	Gate Driver Direction Control	x	1	0	1	1	1	0	0	0	B8h
	1 <sup>st</sup> Parameter	x	0	0	0	0	0	0	0	CTB	00h
C0H	Power_Control1	x	1	1	0	0	0	0	0	0	C0h
	1 <sup>st</sup> Parameter	x	0	0	0	VRH4	VRH3	VRH2	VRH1	VRH0	x
	2 <sup>nd</sup> Parameter	x	0	0	0	0	0	VC2	VC1	VC0	02h
C1H	Power_Control2	x	1	1	0	0	0	0	0	1	C1h
	1 <sup>st</sup> Parameter	x	0	0	0	0	0	BT2	BT1	BT0	07h

C2H	Power_Control3	x	1	1	0	0	0	0	1	0	C2h
	1 <sup>st</sup> Parameter	x	0	0	0	0	0	APA2	APA1	APA0	00h
C3H	Power_Control4	x	1	1	0	0	0	0	1	1	C3h
	1 <sup>st</sup> Parameter	x	0	0	0	0	0	APB2	APB1	APB0	00h
C4H	Power_Control 5	x	1	1	0	0	0	1	0	0	C4h
	1 <sup>st</sup> Parameter	x	0	0	0	0	0	APC2	APC1	APC1	01h
C5H	VCOM_Control 1	x	1	1	0	0	0	1	0	1	C5h
	1 <sup>st</sup> Parameter	x	x	VMH 6	VMH 5	VMH 4	VMH 3	VMH 2	VMH 1	VMH 0	-
	2 <sup>nd</sup> Parameter	x	0	VML6	VML 5	VML 4	VML 3	VML 2	VML 1	VML 0	-
C6H	VCOM_Control 2	x	1	1	0	0	0	1	1	0	C6h
	1 <sup>st</sup> Parameter	x	0	0	VMA 5	VMA 4	VMA 3	VMA 2	VMA 1	VMA 0	13h /06 h
C7H	VCOM Offset Control	x	1	1	0	0	0	1	1	1	C7h
	1 <sup>st</sup> Parameter	0	nVM*	VMF8	VMF5	VMF4	VMF3	VMF2	VMF1	VMF0	40h
D3H	Write ID4 Value	x	1	1	0	1	0	0	1	1	D3h
	1 <sup>st</sup> Parameter	x	x	x	x	x	x	x	x	x	x
	2 <sup>nd</sup> Parameter	x	ID417	ID416	ID415	ID414	ID413	ID412	ID411	ID410	91h
	3 <sup>rd</sup> Parameter	x	ID427	ID426	ID425	ID424	ID423	ID422	ID421	ID420	63h
	4 <sup>th</sup> Parameter	x	x	x	x	x	ID433	ID432	ID431	ID430	00h
	5 <sup>th</sup> Parameter	x	x	x	x	x	x	x	x	x	x
D5H	NV Memory Function Controller(1)	x	1	1	0	1	1	0	1	0	D5h
	1 <sup>st</sup> Parameter	x	ID33	ID32	ID31	ID30	ID23	ID22	ID21	ID20	00h
	2 <sup>nd</sup> Parameter	x	OTP_ BS	0	0	0	OTP_ VMF3	OTP_ VMF2	OTP_ VMF1	OTP_ VMF0	00h

D6H	NV Memory Function Controller(2)	x	1	1	0	1	1	0	1	0	D6h
	1 <sup>st</sup> Parameter	x	OTP_ D[7]	OTP_D [6]	OTP_ D[5]	OTP_ D[4]	OTP_ D[3]	OTP_ D[2]	OTP_ D[1]	OTP_D [0]	00h
	2 <sup>nd</sup> Parameter	x	0	0	0	0	0	0	OTP_ TP[1]	OTP_ TP[0]	00h
D7H	NV Memory Function Controller(3)	x	1	1	0	1	1	0	1	0	D7h
	1 <sup>st</sup> Parameter	x	0	1	0	1	0	1	0	1	55h
	2 <sup>nd</sup> Parameter	x	1	0	1	0	1	0	1	0	AAh

	3 <sup>rd</sup> Parameter	x	0	1	1	0	0	1	1	0	66h	
DAH	Read ID1	x	1	1	0	1	1	0	1	0	DAh	
	1 <sup>st</sup> Parameter	x	x	x	x	x	x	x	x	x	x	
	2 <sup>nd</sup> Parameter	x	ID17	ID16	ID15	ID14	ID13	ID12	ID11	ID10	54h	
DBH	Read ID2	x	1	1	0	1	1	0	1	1	DBh	
	1 <sup>st</sup> Parameter	x	x	x	x	x	x	x	x	x	x	
	2 <sup>nd</sup> Parameter	x	1	ID26	ID25	ID24	ID23	ID22	ID21	ID20	80h	
DCH	Read ID3	x	1	1	0	1	1	1	0	0	DC h	
	1 <sup>st</sup> Parameter	x	x	x	x	x	x	x	x	x	x	
	2 <sup>nd</sup> Parameter	x	ID37	ID36	ID35	ID34	ID33	ID32	ID31	ID30	66h	
E0H	Positive Gamma Correction Setting		1	1	1	0	0	0	0	0	E0h	
	1 <sup>st</sup> Parameter		x	x	VP0[5:0]						-	
	2 <sup>nd</sup> Parameter		x	x	VP1[5:0]						-	
	3 <sup>rd</sup> Parameter		x	x	VP2[5:0]						-	
	4 <sup>th</sup> Parameter		x	x	VP4[5:0]						-	
	5 <sup>th</sup> Parameter		x	x	VP6[5:0]						-	
	6 <sup>th</sup> Parameter		x	x	x	VP13[4:0]					-	
	7 <sup>th</sup> Parameter		x	VP20[8:0]							-	
	8 <sup>th</sup> Parameter		VP36[3:0]				VP27[3:0]				-	
	9 <sup>th</sup> Parameter		x	VP43[6:0]							-	
	10 <sup>th</sup> Parameter		x	x	VP50[5:0]						-	
	11 <sup>st</sup> Parameter		x	x	VP57[5:0]						-	
	12 <sup>nd</sup> Parameter		x	x	VP59[5:0]						-	
	13 <sup>rd</sup> Parameter		x	x	VP61[5:0]						-	
	14 <sup>th</sup> Parameter		x	x	VP62[5:0]						-	
15 <sup>th</sup> Parameter		x	x	VP63[5:0]						-		
E1H	Negative Gamma Correction Setting		1	1	1	0	0	0	0	1	E1h	
	1 <sup>st</sup> Parameter		x	x	VN63[5:0]						-	
	2 <sup>nd</sup> Parameter		x	x	VN62[5:0]						-	
	3 <sup>rd</sup> Parameter		x	x	VN61[5:0]						-	
	4 <sup>th</sup> Parameter		x	x	VN59[5:0]						-	
	5 <sup>th</sup> Parameter		x	x	VN57[5:0]						-	
	6 <sup>th</sup> Parameter		x	x	x	VN50[4:0]					-	

	7 <sup>th</sup> Parameter		x	VN43[6:0]						-		
	8 <sup>th</sup> Parameter		VN27[3:0]			VN38[3:0]			-			
	9 <sup>th</sup> Parameter		x	VN20[6:0]						-		
	10 <sup>th</sup> Parameter		x	x	VN13[5:0]					-		
	11 <sup>st</sup> Parameter		x	x	VN6[5:0]					-		
	12 <sup>nd</sup> Parameter		x	x	VN4[5:0]					-		
	13 <sup>rd</sup> Parameter		x	x	VN2[5:0]					-		
	14 <sup>th</sup> Parameter		x	x	VN1[5:0]					-		
	15 <sup>th</sup> Parameter		x	x	VN0[5:0]					-		
F2H	GAM_R_SEL		1	1	1	1	0	0	1	0	F2h	
	1 <sup>st</sup> Parameter		x	x	x	x	x	x	x	GAM_R_SEL	Write	

## **11. Quality Assurance**

### **11.1. Purpose**

This standard for Quality Assurance assures the quality of LCD module products supplied to customer.

### **11.2. Standard for Quality Test**

#### 11.2.1 Sampling Plan:

GB2828.1-2012

Single sampling, general inspection level II

#### 11.2.2 Sampling Criteria:

Visual inspection: AQL 1.5%

Electrical functional: AQL 0.65%.

#### 11.2.3 Reliability Test:

Detailed requirement refer to Reliability Test Specification.

### **11.3. Nonconforming Analysis & Disposition**

#### 11.3.1 Nonconforming analysis:

11.3.1.1 Customer should provide overall information of non-conforming sample for their complaints.

11.3.1.2 After receipt of detailed information from customer, the analysis of nonconforming parts usually should be finished in one week.

11.3.1.3 If cannot finish the analysis on time, customer will be notified with the progress status.

#### 11.3.2 Disposition of nonconforming:

11.3.2.1 Non-conforming product over PPM level will be replaced.

11.3.2.2 The cause of non-conformance will be analyzed. Corrective action will be discussed and implemented.

### **11.4. Agreement Items**

Shall negotiate with customer if the following situation occurs:

11.4.1 There is any discrepancy in standard of quality assurance.

11.4.2 Additional requirement to be added in product specification.

11.4.3 Any other special problem.

### **11.5. Standard of the Product Visual Inspection**

#### 11.5.1 Appearance inspection:

11.5.1.1 The inspection must be under illumination about 1000 – 1500 lx, and the distance of view must be at 30cm ± 2cm.

11.5.1.2 The viewing angle should be 45° from the vertical line without reflection light or follows customer's viewing angle specifications.

11.5.1.3 Definition of area: A Zone: Active Area, B Zone: Viewing Area,

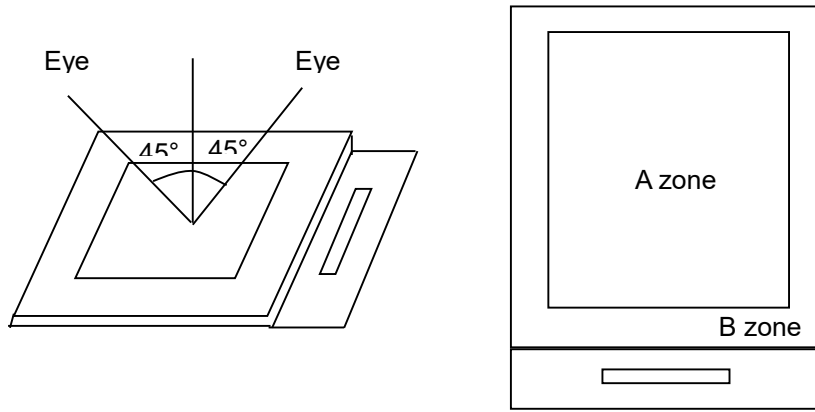

11.5.2 Basic principle:

11.5.2.1 A set of sample to indicate the limit of acceptable quality level must be discussed by both us and customer when there is any dispute happened.

11.5.2.2 New item must be added on time when it is necessary.

**11.6. Inspection Specification**

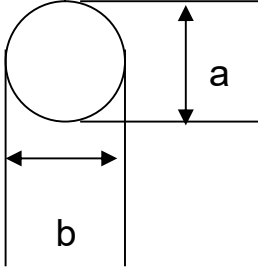
No.	Item	Criteria (Unit: mm)																		
01	Black / White spot Foreign material (Round type) Pinholes Stain Particles inside cell. (Minor defect)	 $\phi = (a + b) / 2$	<table border="1"> <thead> <tr> <th>Size \ Area</th> <th>Acc. Qty</th> </tr> </thead> <tbody> <tr> <td><math>\phi \leq 0.10</math></td> <td>Ignore</td> </tr> <tr> <td><math>0.10 &lt; \phi \leq 0.15</math></td> <td>2</td> </tr> <tr> <td><math>0.15 &lt; \phi \leq 0.25</math></td> <td>1</td> </tr> <tr> <td><math>0.25 &lt; \phi</math></td> <td>0</td> </tr> <tr> <td>Total</td> <td>2 no include <math>\phi \leq 0.10</math></td> </tr> </tbody> </table>	Size \ Area	Acc. Qty	$\phi \leq 0.10$	Ignore	$0.10 < \phi \leq 0.15$	2	$0.15 < \phi \leq 0.25$	1	$0.25 < \phi$	0	Total	2 no include $\phi \leq 0.10$					
			Size \ Area	Acc. Qty																
$\phi \leq 0.10$	Ignore																			
$0.10 < \phi \leq 0.15$	2																			
$0.15 < \phi \leq 0.25$	1																			
$0.25 < \phi$	0																			
Total	2 no include $\phi \leq 0.10$																			
Distance between 2 defects should more than 3mm apart.																				
02	Electrical Defect (Minor defect)	<table border="1"> <thead> <tr> <th></th> <th>Display Area</th> <th>Total</th> <th rowspan="3">Note1</th> </tr> </thead> <tbody> <tr> <td>Bright dot</td> <td>0</td> <td>0</td> </tr> <tr> <td>Dark dot</td> <td><math>N \leq 2</math></td> <td><math>N \leq 2</math></td> </tr> <tr> <td>Total dot</td> <td><math>N \leq 2</math></td> <td><math>N \leq 2</math></td> <td rowspan="2">Note 2</td> </tr> <tr> <td>Mura</td> <td colspan="2">Not visible through 5% ND filters.</td> </tr> </tbody> </table>			Display Area	Total	Note1	Bright dot	0	0	Dark dot	$N \leq 2$	$N \leq 2$	Total dot	$N \leq 2$	$N \leq 2$	Note 2	Mura	Not visible through 5% ND filters.	
			Display Area	Total	Note1															
		Bright dot	0	0																
		Dark dot	$N \leq 2$	$N \leq 2$																
		Total dot	$N \leq 2$	$N \leq 2$	Note 2															
Mura	Not visible through 5% ND filters.																			
Remark:																				
1. Bright dot caused by scratch and foreign object accords to item 1.																				

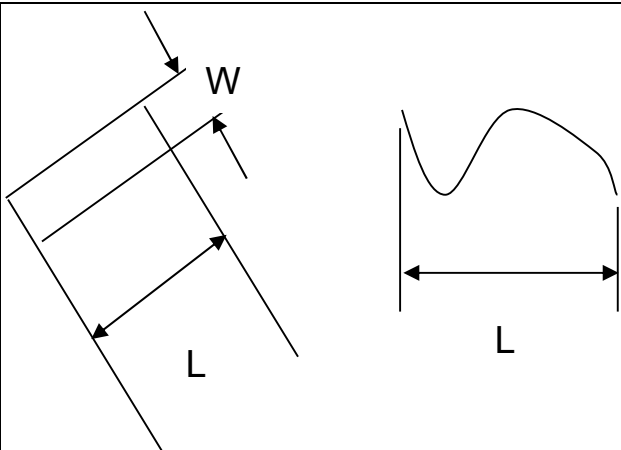
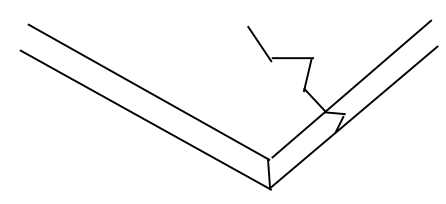
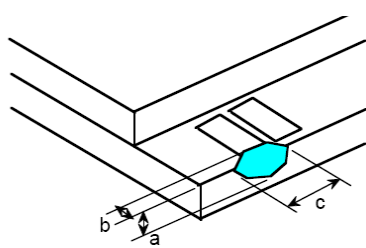
<p>03</p>	<p>Black and White line Scratch Foreign material (Line type) (Minor defect)</p>	 <table border="1" data-bbox="606 638 1236 952"> <thead> <tr> <th>Length</th> <th>Width</th> <th>Acc. Qty</th> </tr> </thead> <tbody> <tr> <td>/</td> <td><math>W \leq 0.03</math></td> <td>Ignore</td> </tr> <tr> <td><math>L \leq 2.5</math></td> <td><math>0.03 &lt; W \leq 0.05</math></td> <td>3</td> </tr> <tr> <td><math>L \leq 2.5</math></td> <td><math>0.05 &lt; W \leq 0.10</math></td> <td>2</td> </tr> <tr> <td>/</td> <td><math>0.1 &lt; W</math></td> <td>0</td> </tr> <tr> <td colspan="2">Total</td> <td>3</td> </tr> </tbody> </table> <p>Distance between 2 defects should more than 3mm apart. Scratches not viewable through the back of the display are acceptable.</p>	Length	Width	Acc. Qty	/	$W \leq 0.03$	Ignore	$L \leq 2.5$	$0.03 < W \leq 0.05$	3	$L \leq 2.5$	$0.05 < W \leq 0.10$	2	/	$0.1 < W$	0	Total		3
Length	Width	Acc. Qty																		
/	$W \leq 0.03$	Ignore																		
$L \leq 2.5$	$0.03 < W \leq 0.05$	3																		
$L \leq 2.5$	$0.05 < W \leq 0.10$	2																		
/	$0.1 < W$	0																		
Total		3																		
<p>04</p>	<p>Glass Crack (Minor defect)</p>	 <p>Crack is potential to enlarge, any type is not allowed.</p>																		
<p>05</p>	<p>Glass Chipping Pad Area: (Minor defect)</p> 	<table border="1" data-bbox="845 1523 1324 1702"> <thead> <tr> <th>Length and Width</th> <th>Acc. Qty</th> </tr> </thead> <tbody> <tr> <td><math>c &gt; 3.0, b &lt; 1.0</math></td> <td>1</td> </tr> <tr> <td><math>c &lt; 3.0, b &lt; 1.0</math></td> <td>3</td> </tr> <tr> <td colspan="2"><math>a &lt; \text{Glass Thickness}</math></td> </tr> </tbody> </table>	Length and Width	Acc. Qty	$c > 3.0, b < 1.0$	1	$c < 3.0, b < 1.0$	3	$a < \text{Glass Thickness}$											
Length and Width	Acc. Qty																			
$c > 3.0, b < 1.0$	1																			
$c < 3.0, b < 1.0$	3																			
$a < \text{Glass Thickness}$																				

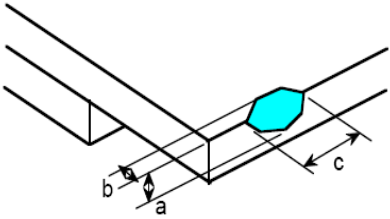
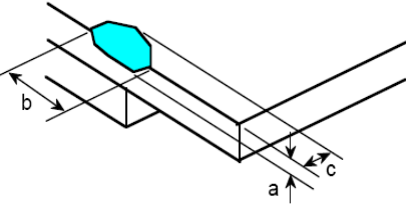
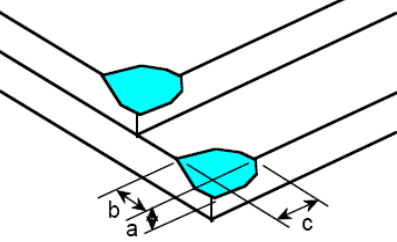
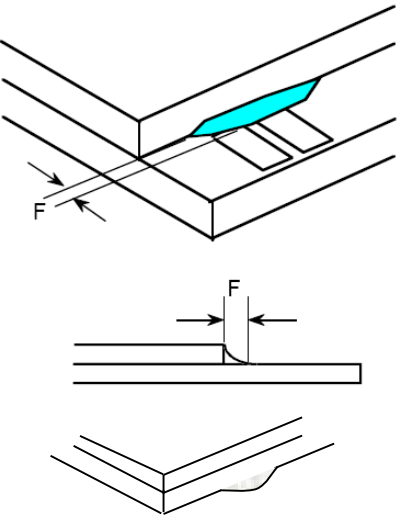
<p>06</p>	<p>Glass Chipping Rear of Pad Area: (Minor defect)</p> 	<table border="1"> <thead> <tr> <th>Length and Width</th> <th>Acc. Qty</th> </tr> </thead> <tbody> <tr> <td><math>c &gt; 3.0, b &lt; 1.0</math></td> <td>1</td> </tr> <tr> <td><math>c &lt; 3.0, b &lt; 1.0</math></td> <td>2</td> </tr> <tr> <td><math>c &lt; 3.0, b &lt; 0.5</math></td> <td>4</td> </tr> <tr> <td colspan="2" style="text-align: center;"><math>a &lt; \text{Glass Thickness}</math></td> </tr> </tbody> </table>	Length and Width	Acc. Qty	$c > 3.0, b < 1.0$	1	$c < 3.0, b < 1.0$	2	$c < 3.0, b < 0.5$	4	$a < \text{Glass Thickness}$	
Length and Width	Acc. Qty											
$c > 3.0, b < 1.0$	1											
$c < 3.0, b < 1.0$	2											
$c < 3.0, b < 0.5$	4											
$a < \text{Glass Thickness}$												
<p>07</p>	<p>Glass Chipping Except Pad Area: (Minor defect)</p> 	<table border="1"> <thead> <tr> <th>Length and Width</th> <th>Acc. Qty</th> </tr> </thead> <tbody> <tr> <td><math>c &gt; 3.0, b &lt; 1.0</math></td> <td>1</td> </tr> <tr> <td><math>c &lt; 3.0, b &lt; 1.0</math></td> <td>2</td> </tr> <tr> <td><math>c &lt; 3.0, b &lt; 0.5</math></td> <td>4</td> </tr> <tr> <td colspan="2" style="text-align: center;"><math>a &lt; \text{Glass Thickness}</math></td> </tr> </tbody> </table>	Length and Width	Acc. Qty	$c > 3.0, b < 1.0$	1	$c < 3.0, b < 1.0$	2	$c < 3.0, b < 0.5$	4	$a < \text{Glass Thickness}$	
Length and Width	Acc. Qty											
$c > 3.0, b < 1.0$	1											
$c < 3.0, b < 1.0$	2											
$c < 3.0, b < 0.5$	4											
$a < \text{Glass Thickness}$												
<p>08</p>	<p>Glass Corner Chipping: (Minor defect)</p> 	<table border="1"> <thead> <tr> <th>Length and Width</th> <th>Acc. Qty</th> </tr> </thead> <tbody> <tr> <td><math>c &lt; 3.0, b &lt; 3.0</math></td> <td>Ignore</td> </tr> <tr> <td colspan="2" style="text-align: center;"><math>a &lt; \text{Glass Thickness}</math></td> </tr> </tbody> </table>	Length and Width	Acc. Qty	$c < 3.0, b < 3.0$	Ignore	$a < \text{Glass Thickness}$					
Length and Width	Acc. Qty											
$c < 3.0, b < 3.0$	Ignore											
$a < \text{Glass Thickness}$												
<p>09</p>	<p>Glass Burr: (Minor defect)</p> 	<table border="1"> <thead> <tr> <th>Length</th> <th>Acc. Qty</th> </tr> </thead> <tbody> <tr> <td><math>F &lt; 1.0</math></td> <td>Ignore</td> </tr> </tbody> </table> <p>Glass burr don't affect assemble and module dimension.</p>	Length	Acc. Qty	$F < 1.0$	Ignore						
Length	Acc. Qty											
$F < 1.0$	Ignore											

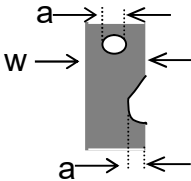

10	<p>FPC Defect: (Minor defect)</p> 	<p>10.1 Dent, pinhole width <math>a &lt; w/3</math>. (<math>w</math>: circuitry width.)</p> <p>10.2 Open circuit is unacceptable.</p> <p>10.3 No oxidation, contamination and distortion.</p>										
11	Bubble on Polarizer (Minor defect)	<table border="1"> <thead> <tr> <th>Diameter</th> <th>Acc. Qty</th> </tr> </thead> <tbody> <tr> <td><math>\varphi \leq 0.20</math></td> <td>Ignore</td> </tr> <tr> <td><math>0.20 &lt; \varphi \leq 0.30</math></td> <td>4</td> </tr> <tr> <td><math>0.30 &lt; \varphi \leq 0.50</math></td> <td>1</td> </tr> <tr> <td><math>0.50 &lt; \varphi</math></td> <td>None</td> </tr> </tbody> </table>	Diameter	Acc. Qty	$\varphi \leq 0.20$	Ignore	$0.20 < \varphi \leq 0.30$	4	$0.30 < \varphi \leq 0.50$	1	$0.50 < \varphi$	None
Diameter	Acc. Qty											
$\varphi \leq 0.20$	Ignore											
$0.20 < \varphi \leq 0.30$	4											
$0.30 < \varphi \leq 0.50$	1											
$0.50 < \varphi$	None											
12	Dent on Polarizer (Minor defect)	<table border="1"> <thead> <tr> <th>Diameter</th> <th>Acc. Qty</th> </tr> </thead> <tbody> <tr> <td><math>\varphi \leq 0.20</math></td> <td>Ignore</td> </tr> <tr> <td><math>0.20 &lt; \varphi \leq 0.30</math></td> <td>4</td> </tr> <tr> <td><math>0.30 &lt; \varphi \leq 0.50</math></td> <td>1</td> </tr> <tr> <td><math>0.50 &lt; \varphi</math></td> <td>None</td> </tr> </tbody> </table>	Diameter	Acc. Qty	$\varphi \leq 0.20$	Ignore	$0.20 < \varphi \leq 0.30$	4	$0.30 < \varphi \leq 0.50$	1	$0.50 < \varphi$	None
Diameter	Acc. Qty											
$\varphi \leq 0.20$	Ignore											
$0.20 < \varphi \leq 0.30$	4											
$0.30 < \varphi \leq 0.50$	1											
$0.50 < \varphi$	None											
13	Bezel	<p>13.1 No rust, distortion on the Bezel.</p> <p>13.2 No visible fingerprints, stains or other contamination.</p>										
14	Touch Panel	<p>D: Diameter W: width L: length</p> <p>14.1 Spot: <math>D &lt; 0.25</math> is acceptable <math>0.25 \leq D \leq 0.4</math></p> <p>2dots are acceptable and the distance between defects should more than 10 mm. <math>D &gt; 0.4</math> is unacceptable</p> <p>14.2 Dent: <math>D &gt; 0.40</math> is unacceptable</p> <p>14.3 Scratch: <math>W \leq 0.03</math>, <math>L \leq 10</math> is acceptable, <math>0.03 &lt; W \leq 0.10</math>, <math>L \leq 10</math> is acceptable</p> <p>Distance between 2 defects should more than 10 mm. <math>W &gt; 0.10</math> is unacceptable.</p>										
15	PCB	<p>15.1 No distortion or contamination on PCB terminals.</p> <p>15.2 All components on PCB must same as documented on the BOM/component layout.</p> <p>15.3 Follow IPC-A-600F.</p>										

16	Soldering	Follow IPC-A-610C standard
17	Electrical Defect (Major defect)	The below defects must be rejected. 17.1 Missing vertical / horizontal segment, 17.2 Abnormal Display. 17.3 No function or no display. 17.4 Current exceeds product specifications. 17.5 LCD viewing angle defect. 17.6 No Backlight. 17.7 Dark Backlight. 17.8 Touch Panel no function.

Remark: LCD Panel Broken shall be rejected. Defect out of LCD viewing area is acceptable.

**11.7. Classification of Defects**

11.7.1 Visual defects (Except no / wrong label) are treated as minor defect and electrical defect is major.

11.7.2 Two minor defects are equal to one major in lot sampling inspection.

**11.8. Identification/marketing criteria**

Any unit with illegible / wrong /double or no marking/ label shall be rejected.

**11.9. Packaging**

11.9.1 There should be no damage of the outside carton box, each packaging box should have one identical label.

11.9.2 Modules inside package box should have compliant mark.

11.9.3 All direct package materials shall offer ESD protection

**Note1:** Bright dot is defined as the defective area of the dot is larger than 50% of one sub-pixel area.

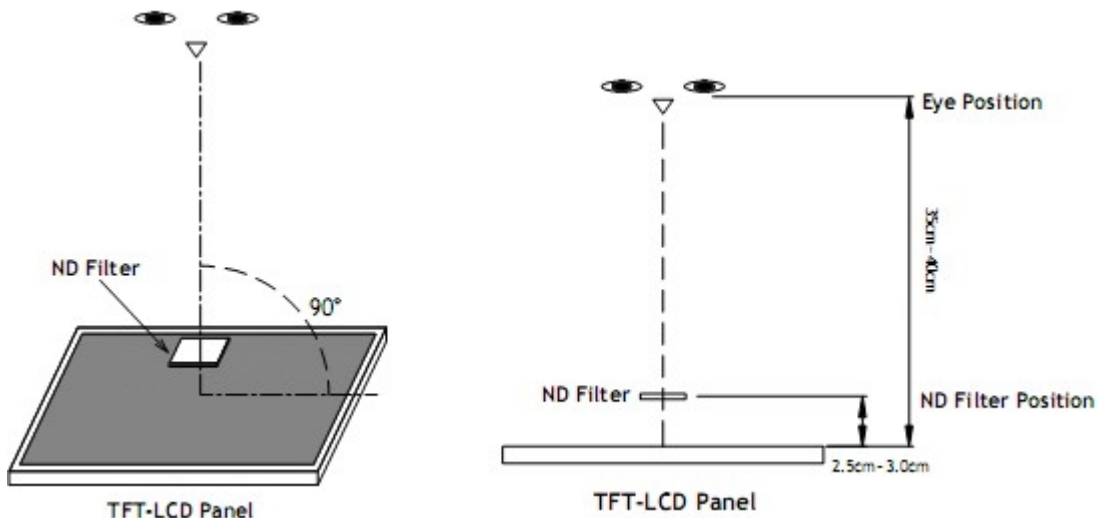

Bright dot: The bright dot size defect at black display pattern. It can be recognized by 2% transparency of filter when the distance between eyes and panel is 350mm±50mm.

Dark dot: Cyan, Magenta or Yellow dot size defect at white display pattern. It can be recognized by 5% transparency of filter when the distance between eyes and panel is 350mm±50mm.

**Note2:** Mura on display which appears darker / brighter against background brightness on parts of display area.

**12. Reliability Specification**

No	Item	Condition	Quantity	Criteria
1	High Temperature Operating	+70°C, 96Hrs	2	GB/T2423.2-2008
2	Low Temperature Operating	-20°C, 96Hrs	2	GB/T2423.1-2008
3	High Humidity	+50°C, 90%RH, 96Hrs	2	GB/T2423.3-2006
4	High Temperature Storage	+80°C, 96Hrs	2	GB/T2423.2-2008
5	Low Temperature Storage	-30°C, 96Hrs	2	GB/T2423.1-2008
6	Thermal Cycling Test	-20°C, 60min ~ +70°C, 60min, 20 cycles.	2	GB/T2423.22-2012
7	Packing Vibration	Frequency range:10Hz~50Hz Acceleration of gravity:5G X, Y, Z 30 min for each direction.	2	GB/T5170.14-2009
8	Electrical Static Discharge	Air: ±8kV 150pF/330 Ω 5 times	2	GB/T17626.2-2006
		Contact: ±4kV 150pF/330 Ω 5 times		
9	Drop Test (Packaged)	Height: 80 cm,1 corner, 3 edges, 6 surfaces.	2	GB/T2423.8-1995

Note1. No deflection cosmetic and operational function allowable.

Note2. Total current Consumption should be below double of initial value

**13. Precautions and Warranty**

**13.1 Safety**

- 13.1.1. The liquid crystal in the LCD is poisonous. Do not put it in your mouth. If the liquid crystal touches your skin or clothes, wash it off immediately using soap and water.
- 13.1.2. Since the liquid crystal cells are made of glass, do not apply strong impact on them. Handle with care.

**13.2. Handling**

- 13.2.1. Reverse and use within ratings in order to keep performance and prevent damage.
- 13.2.2. Do not wipe the polarizer with dry cloth, as it might cause scratch. If the surface of the LCD needs to be cleaned, wipe it swiftly with cotton or other soft cloth soaked with petroleum IPA, do not use other chemicals.

**13.3. Storage**

- 13.3.1. Do not store the LCD module beyond the specified temperature ranges.
- 13.3.2. Strong light exposure causes degradation of polarizer and color filter.

**13.4. Metal Pin (Apply to Products with Metal Pins)**

- 13.4.1. Pins of LCD and Backlight
  - 13.4.1.1. Solder tip can touch and press on the tip of Pin LEAD during the soldering

13.4.1.2. Recommended Soldering Conditions

Solder Type: Sn96.3~94-Ag3.3~4.3-Cu0.4~1.1

Maximum Solder Temperature: 370°C

Maximum Solder Time: 3s at the maximum temperature

Recommended Soldering Temp: 350±20°C

Typical Soldering Time: ≤3s

13.4.1.3. Solder Wetting

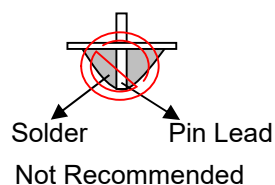
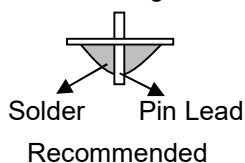

13.4.2. Pins of EL

- 13.4.2.1. Solder tip can touch and press on the tip of EL leads during soldering.
- 13.4.2.2. No Solder Paste on the soldering pad on the motherboard is recommended.

13.4.2.3. Recommended Soldering Conditions

Solder type: Nippon Alimit Leadfree SR-34, size 0.5mm

Recommended Solder Temperature: 270~290°C

Typical Soldering Time: ≤2s

Minimum solder distance from EL lamp (body):2.0mm

- 13.4.2.4. No horizontal press on the EL leads during soldering.

- 13.4.2.5. 180° bend EL leads three times is not allowed.

13.4.2.6. Solder Wetting

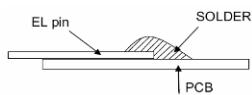

Recommended

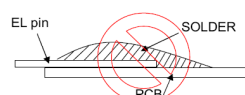

Not Recommended

13.4.2.7. The type of the solder iron:

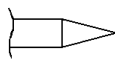

Recommended

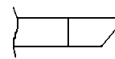

Not Recommended

13.4.2.8. Solder Pad

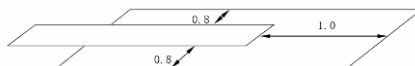

**13.5.Operation**

- 13.5.1. Do not drive LCD with DC voltage
- 13.5.2. Response time will increase below lower temperature
- 13.5.3. Display may change color with different temperature
- 13.5.4. Mechanical disturbance during operation, such as pressing on the display area, may cause the segments to appear “fractured”.
- 13.5.5. Do not connect or disconnect the LCM to or from the system when power is on.
- 13.5.6. Never use the LCM under abnormal condition of high temperature and high humidity.
- 13.5.7. Module has high frequency circuits. Sufficient suppression to the electromagnetic interface shall be done by system manufacturers. Grounding and shielding methods may be important to minimize the interference.
- 13.5.8. Do not display the fixed pattern for long time (we suggest the time not longer than one hour) because it may develop image sticking due to the TFT structure.

**13.6.Static Electricity**

- 13.6.1. CMOS LSIs are equipped in this unit, so care must be taken to avoid the electro-static charge, by ground human body, etc.
- 13.6.2. The normal static prevention measures should be observed for work clothes and benches.
- 13.6.3. The module should be kept into anti-static bags or other containers resistant to static for storage.

**13.7.Limited Warranty**

- 13.7.1. Our warranty liability is limited to repair and/or replacement. We will not be responsible for any consequential loss.
- 13.7.2. If possible, we suggest customer to use up all modules in six months. If the module storage time over twelve months, we suggest that recheck it before the module be used.
- 13.7.3. After the product shipped, any product quality issues must be feedback within three months, otherwise, we will not be responsible for the subsequent or consequential events.

14. Outline Drawing

No.	PIN NAME
1	GND
2	I/O/CC 1.8V
3	VCC2.8V
4	CSB
5	RST
6	RS
7	WRB
8	RDB
9	DB0
10	DB1
11	DB2
12	DB3
13	DB4
14	DB5
15	DB6
16	DB7
17	BL_A
18	BL_K1
19	BL_K2
20	GND

