DISPLAY Elektronik GmbH

DATA SHEET

LCD MODULE

DEM 240128A1 SBH-PW-N

Product Specification

Version: 2

22.09.2021

GENERAL SPECIFICATION

MODULE NO. :

DEM 240128A1 SBH-PW-N

CUSTOMER P/N:

Version NO.	Change Description	Date
0	Original Version	07.07.2021
1	Change Pin Description on the Page 8	08.07.2021
2	Correct the UL No. on the FPC in the drawing on page 3 - page 5.	22.09.2021

PREPARED BY: CC

DATE: 22.09.2021

APPROVED By: WH

DATE: 22.09.2021

CONTENTS

1. FUNCTIONS & FEATURES 3

2. MECHANICAL SPECIFICATIONS 3

3. EXTERNAL DIMENSIONS 4

4. BLOCK DIAGRAM 5

5. PIN ASSIGNMENT 6

6. BACKLIGHT DRAWING..... 8

7. ABSOLUTE MAXIMUM RATINGS 9

8. DC CHARACTERISTICS 9

9. AC ELECTRICAL CHARACTERISTICS 10

10. COMMAND TABLE 14

11. ACCEPT QUALITY LEVEL (AQL)..... 16

12. RELIABILITY TEST 16

13. QUALITY DESCRIPTION..... 17

14. LCD MODULES HANDLING PRECAUTIONS 18

15. OTHERS 18

1. FUNCTIONS & FEATURES

Module	LCD Type	Remark
DEM 240128A1 SBH-PW-N	STN-Blue Transmissive Negative Mode	

- | Viewing Direction : 6 O'clock
- | Driving Scheme : 1/128Duty Cycle, 1/12 Bias
- | Power Supply Voltage : 3.0 V
- | LCD Operation Voltage : 14.5V
- | Driver IC : ST7529A
- | Display Contents : 240 x 128 Dots
- | RoHS Compliant

2. MECHANICAL SPECIFICATIONS

- | Module Size(Without FPC) : 98.70 x 67.70 x 5.70mm
- | View Area : 92.00 x 53.00mm
- | Active Area : 83.975 x 44.775mm
- | Dot Size : 0.325 x 0.325mm
- | Dot Pitch : 0.35 x 0.35mm

4. BLOCK DIAGRAM

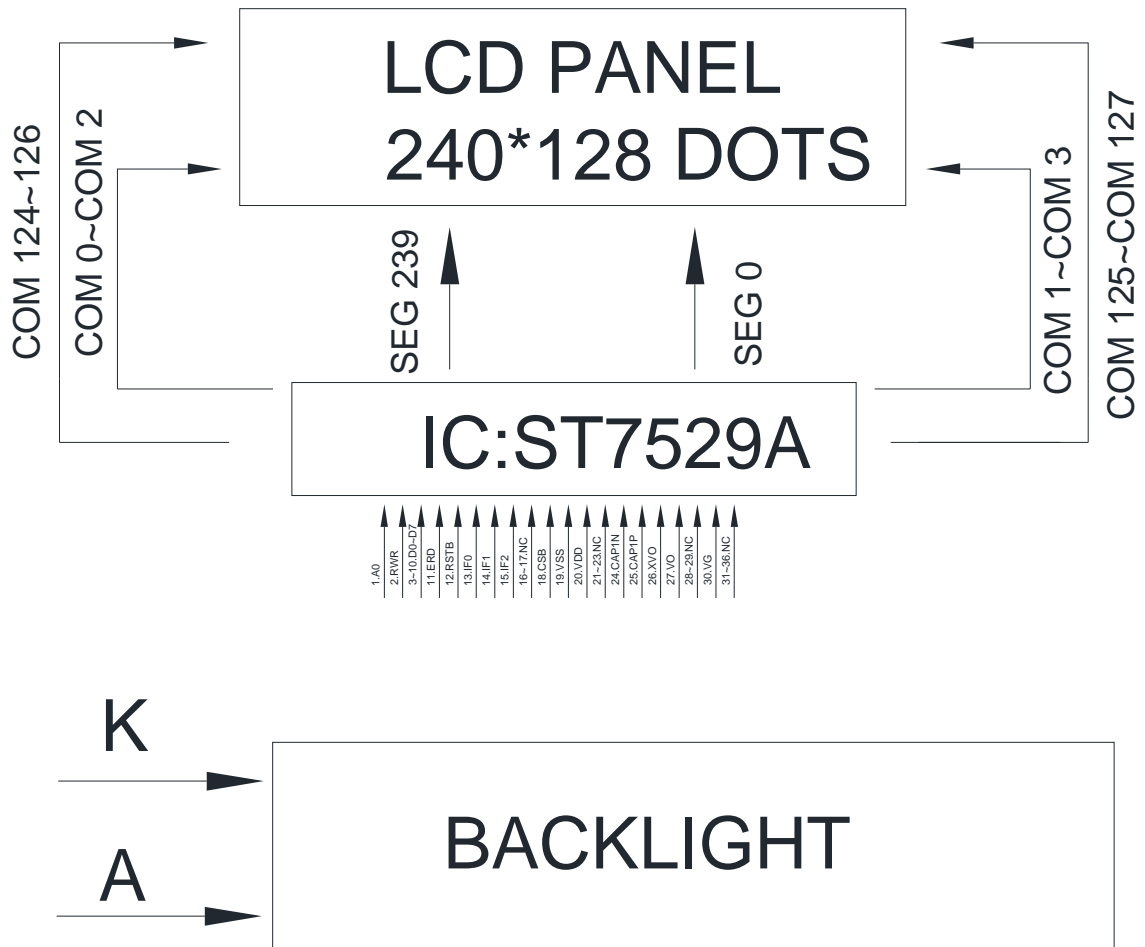

5. PIN ASSIGNMENT

Pin No.	Name	Description																		
1	A0	Register select input pin A0 = "H": DB0 to DB7 or SI are display data A0 = "L": DB0 to DB7 or SI are control data There is no A0 pin in 3-Line SPI interface. A0 should be fixed to "H" by VDD1.																		
2	RWR	Read / Write execution control pin																		
		<table border="1"> <thead> <tr> <th>MPU type</th> <th>RWR</th> <th>Description</th> </tr> </thead> <tbody> <tr> <td>6800-series</td> <td>RW</td> <td>Read / Write control input pin RW = "H" : read RW = "L" : write</td> </tr> <tr> <td>8080-series</td> <td>/WR</td> <td>Write enable clock input pin The data on DB0 to DB7 are latched at the rising edge of the /WR signal.</td> </tr> </tbody> </table>	MPU type	RWR	Description	6800-series	RW	Read / Write control input pin RW = "H" : read RW = "L" : write	8080-series	/WR	Write enable clock input pin The data on DB0 to DB7 are latched at the rising edge of the /WR signal.									
		MPU type	RWR	Description																
6800-series	RW	Read / Write control input pin RW = "H" : read RW = "L" : write																		
8080-series	/WR	Write enable clock input pin The data on DB0 to DB7 are latched at the rising edge of the /WR signal.																		
This pin is not used in serial interfaces and should be connected to VDD.																				
3	D0	When using 8-bit parallel interface: 8080 or 6800 mode 8 bit bi-directional data bus. Connect to the data bus of 8-bit microprocessor. When CSBis "H" , D[7:0] are high impedance. When using serial interface : 4-line SPI or 3-line SPI mode D[0:3] : fix to "H" by VDD1. D[4:6] : serial input/output data (SDA). D[7] : serial input clock (SCL). D4to D6must be connected together (SDA) When CSBis "H", D[7:0] are high impedance.																		
4	D1																			
5	D2																			
6	D3																			
7	D4																			
8	D5																			
9	D6																			
10	D7																			
11	ERD		Read / Write execution control pin																	
			<table border="1"> <thead> <tr> <th>MPU Type</th> <th>ERD</th> <th>Description</th> </tr> </thead> <tbody> <tr> <td>6800-series</td> <td>E</td> <td>Read / Write control input pin RW = "H": When E is "H", DB0 to DB7 are in an output status. RW = "L": The data on DB0 to DB7 are latched at the falling edge of the E signal.</td> </tr> <tr> <td>8080-series</td> <td>/RD</td> <td>Read enable clock input pin When /RD is "L", DB0 to DB7 are in an output status.</td> </tr> </tbody> </table>	MPU Type	ERD	Description	6800-series	E	Read / Write control input pin RW = "H": When E is "H", DB0 to DB7 are in an output status. RW = "L": The data on DB0 to DB7 are latched at the falling edge of the E signal.	8080-series	/RD	Read enable clock input pin When /RD is "L", DB0 to DB7 are in an output status.								
		MPU Type	ERD	Description																
6800-series	E	Read / Write control input pin RW = "H": When E is "H", DB0 to DB7 are in an output status. RW = "L": The data on DB0 to DB7 are latched at the falling edge of the E signal.																		
8080-series	/RD	Read enable clock input pin When /RD is "L", DB0 to DB7 are in an output status.																		
12	RSB	Reset input pin When RST is "L", initialization is executed.																		
13	IF0	Parallel / Serial data input select input																		
		<table border="1"> <thead> <tr> <th>IF0</th> <th>IF1</th> <th>IF2</th> <th>MPU interface type</th> </tr> </thead> <tbody> <tr> <td>H</td> <td>H</td> <td>L</td> <td>80 series 8-bit parallel</td> </tr> <tr> <td>L</td> <td>H</td> <td>H</td> <td>68 series 8-bit parallel</td> </tr> <tr> <td>L</td> <td>L</td> <td>H</td> <td>9-bit serial (3 line)</td> </tr> <tr> <td>L</td> <td>L</td> <td>L</td> <td>8-bit serial (4 line)</td> </tr> </tbody> </table>	IF0	IF1	IF2	MPU interface type	H	H	L	80 series 8-bit parallel	L	H	H	68 series 8-bit parallel	L	L	H	9-bit serial (3 line)	L	L
IF0	IF1	IF2	MPU interface type																	
H	H	L	80 series 8-bit parallel																	
L	H	H	68 series 8-bit parallel																	
L	L	H	9-bit serial (3 line)																	
L	L	L	8-bit serial (4 line)																	
14	IF1																			
15	IF2																			

16	NC	No connect
17	NC	
18	CSB	Chip select input pins Data/instruction I/O is enabled only when CSB is "L". When chip select is non-active, DB0 to DB7 may be high impedance.
19	VSS	Ground
20	VDD	Power supply
21	NC	No connect
22	NC	
23	NC	
24	CAP1N	DC/DC Voltage Converter
25	CAP1P	
26	XVO	Negative operating voltage of COM-drivers.
27	VO	Positive operating voltage of COM-drivers.
28	NC	No connect
29	NC	
30	VG	VG is the power of SEG-drivers.
31~36	NC	No connect

Please note: Only support 10x boosting !

7. ABSOLUTE MAXIMUM RATINGS

Parameter	Symbol	Min	Max	Unit
Power Supply Voltage	VDD	-0.5	+4.0	V
Power supply voltage (VDD standard)	V0-XV0	-0.5	+19	V
Power supply voltage (VDD standard)	VG	-0.3	VDD+0.3	V
Operating Temperature	Topr	-20	+70	°C
Storage Temperature	Tstr	-30	+80	°C

8. DC CHARACTERISTICS

Item	Symbol	Standard Value			Test Condition	Unit
		Min.	Typ.	Max.		
Power supply Voltage	VDD	2.7	3.0	3.3		V
Operating Voltage	Vop	14.2	14.5	14.8		
Current Consumption	IDD	---	TBD	---		mA

9. AC ELECTRICAL CHARACTERISTICS

9.1 System bus READ/WRITE characteristics for the 8080 series MPU

Item	Signal	Symbol	Condition	Rating		Units
				Min.	Max.	
Address hold time	A0	tAH8	-	40	-	ns
Address setup time		tAW8	-	20	-	
System cycle time	WR	tCYC8	-	380	-	
Enable L pulse width (WRITE)		tCCLW	-	80	-	
Enable H pulse width (WRITE)		tCCHW	-	300	-	
Enable L pulse width (READ)	RD	tCCLR	-	230	-	
Enable H pulse width (READ)		tCCHR	-	500	-	
WRITE Data setup time	D0 to D7	tDS8	-	250	-	
WRITE Address hold time		tDH8	-	20	-	
READ access time		tACC8	CL = 100 pF	-	40	
READ Output disable time		tOH8	CL = 100 pF	-	30	

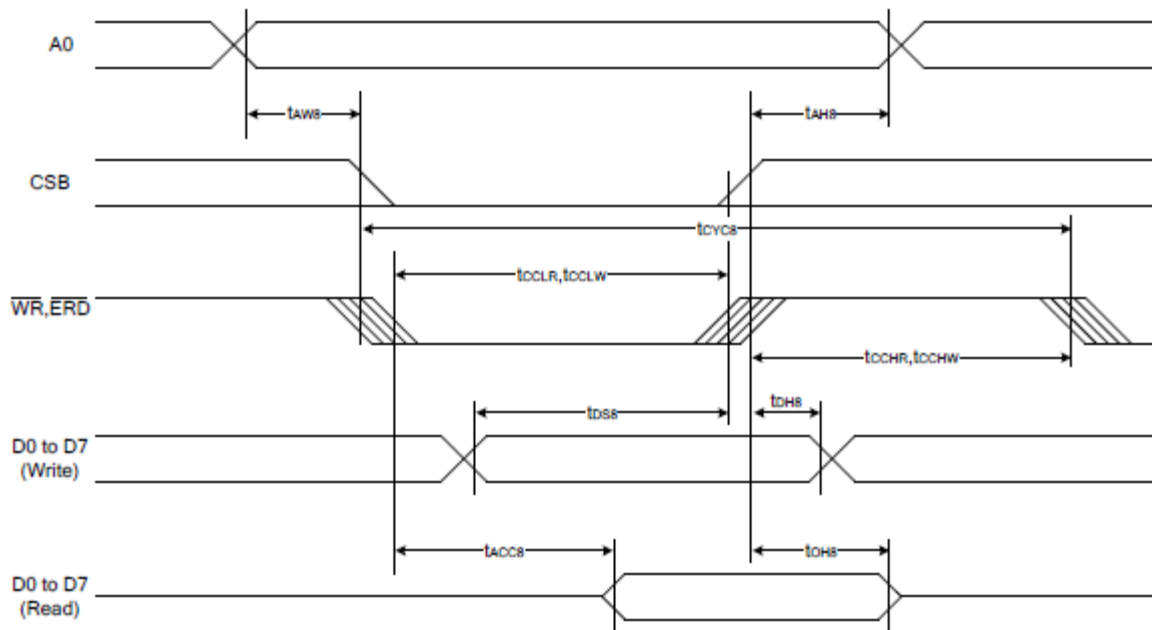

9.2 System bus READ/WRITE characteristics for the 6800 series MPU

Item	Signal	Symbol	Condition	Rating		Units
				Min.	Max.	
Address hold time	A0	tAH6	-	20	-	ns
Address setup time		tAW6	-	20	-	
System cycle time	E	tCYC6	-	470	-	
Enable L pulse width (WRITE)		tEWLW	-	330	-	
Enable H pulse width (WRITE)		tEWHW	-	140	-	
Enable L pulse width (READ)	E	tEWLR	-	500	-	
Enable H pulse width (READ)		tEWHR	-	230	-	
WRITE Data setup time	D0 to D7	tDS6	-	240	-	
WRITE Address hold time		tDH6	-	230	-	
READ access time		tACC6	CL = 100 pF	-	40	
READ Output disable time		tOH6	CL = 100 pF	-	30	

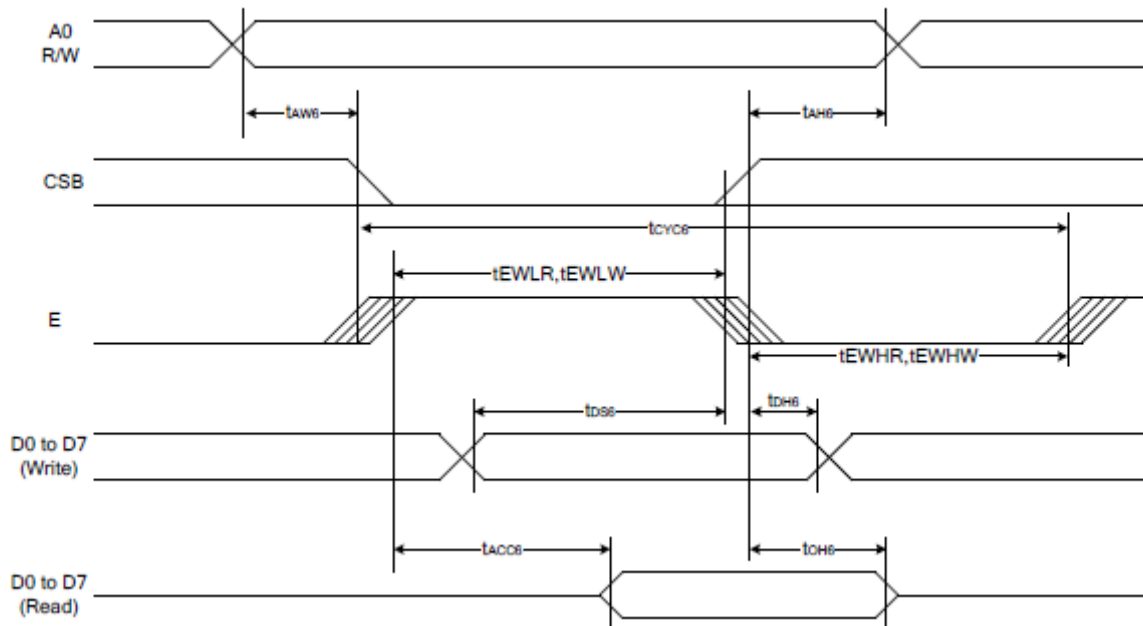

9.3 The Serial Interface (4-Line interface)

Item	Signal	Symbol	Condition	Rating		Units
				Min.	Max.	
Serial Clock Period	SCL	tSCYC	-	130	-	ns
SCL "H" pulse width		tSHW	-	80	-	
SCL "L" pulse width		tSLW	-	50	-	
Address setup time	A0	tSAS	-	40	-	
Address hold time		tSAH	-	30	-	
Data setup time	SDA	tSDS	-	40	-	
Data hold time		tSDH	-	30	-	
CS-SCL time	CSB	tCSS	-	20	-	
CS-SCL time		tCSH	-	60	-	

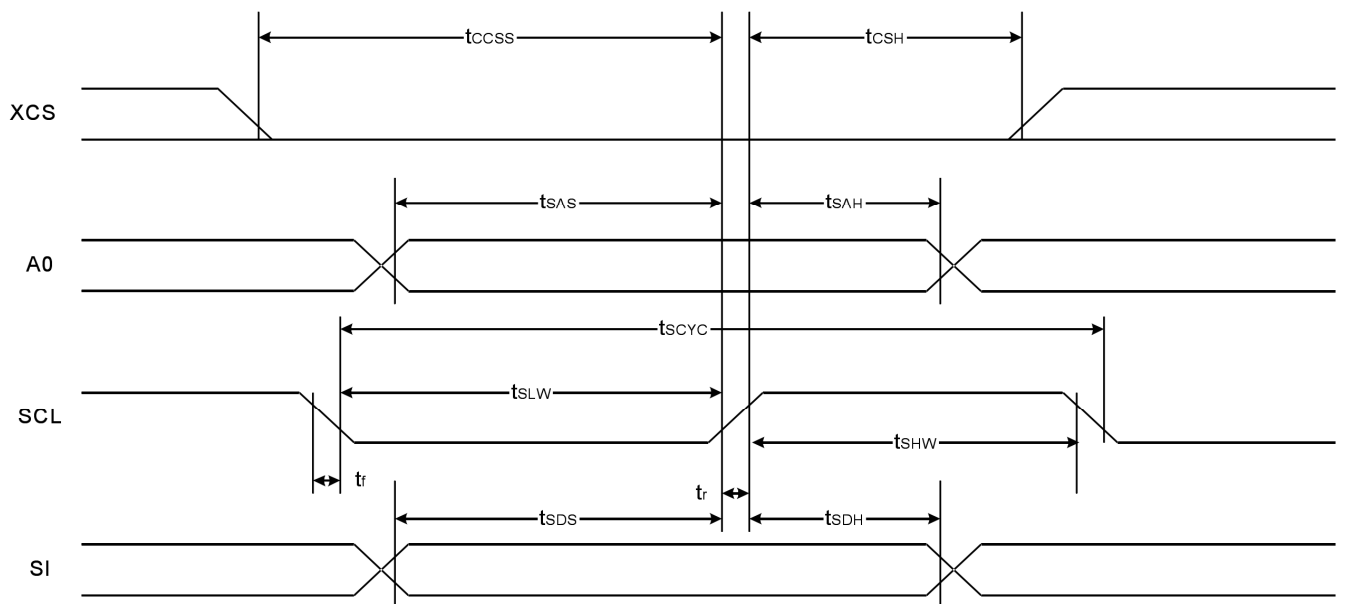

9.4 The Serial Interface (3-Line interface)

Item	Signal	Symbol	Condition	Rating		Units
				Min.	Max.	
Serial Clock Period	SCL	tSCYC	-	130	-	ns
SCL "H" pulse width		tSHW	-	80	-	
SCL "L" pulse width		tSLW	-	50	-	
Data setup time	SI	tSDS	-	40	-	
Data hold time		tSDH	-	30	-	
CS-SCL time	CSB	tCSS	-	20	-	
CS-SCL time		tCSH	-	60	-	

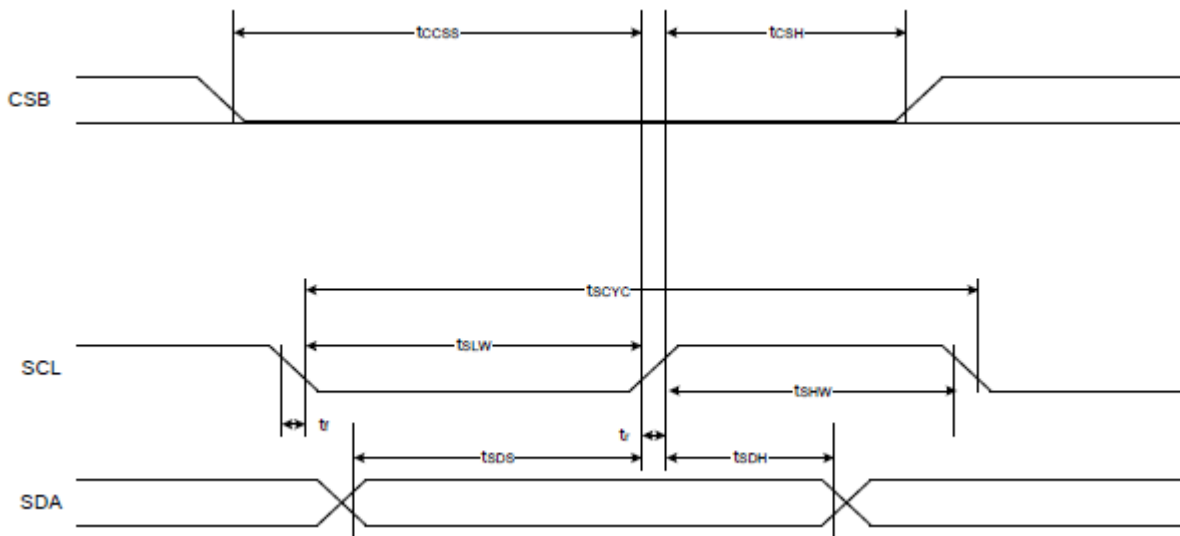

10. COMMAND TABLE

Ext=0 or Ext=1 or Ext=2

Index	Command	A0	RD	WR	D7	D6	D5	D4	D3	D2	D1	D0	Function	Hex	Parameter
1	Ext 0	0	1	0	0	0	1	1	0	0	0	0	Ext=0 Set	30	None
2	Ext 1	0	1	0	0	0	1	1	0	0	0	1	Ext=1 Set	31	None
3	Ext 2	0	1	0	0	0	1	1	1	0	0	1	Ext=2 Set	39	None

Ext=0

Index	Command	A0	RD	WR	D7	D6	D5	D4	D3	D2	D1	D0	Function	Hex	Parameter
1	DISON	0	1	0	1	0	1	0	1	1	1	1	Display On	AF	None
2	DISOFF	0	1	0	1	0	1	0	1	1	1	0	Display Off	AE	None
3	DISNOR	0	1	0	1	0	1	0	0	1	1	1	Normal Display	A7	None
4	DISINV	0	1	0	1	0	1	0	0	1	1	0	Inverse Display	A6	None
5	DISCTRL	0	1	0	1	1	0	0	1	0	1	0	Display Control	CA	3 bytes
6	SLPIN	0	1	0	1	0	0	1	0	1	0	1	Sleep In	95	None
7	SLPOUT	0	1	0	1	0	0	1	0	1	0	0	Sleep Out	94	None
8	LASET	0	1	0	0	1	1	1	0	1	0	1	Line Address Set	75	2 bytes
9	CASET	0	1	0	0	0	0	1	0	1	0	1	Column Address Set	15	2 bytes
10	DATSDR	0	1	0	1	0	1	1	1	1	0	0	Data Scan Direction	BC	1 byte
11	RAMWR	0	1	0	0	1	0	1	1	1	0	0	Writing to Memory	5C	Data
12	RAMRD	0	1	0	0	1	0	1	1	1	0	1	Reading from Memory	5D	Data
13	PTLIN	0	1	0	1	0	1	0	1	0	0	0	Partial display in	A8	2 bytes
14	PTLOUT	0	1	0	1	0	1	0	1	0	0	1	Partial display out	A9	None
15	RMWIN	0	1	0	1	1	1	0	0	0	0	0	Read and Modify Write	E0	None
16	RMWOUT	0	1	0	1	1	1	0	1	1	1	0	RMW end	EE	None
17	ASCSET	0	1	0	1	0	1	0	1	0	1	0	Area Scroll Set	AA	4 bytes
18	SCSTART	0	1	0	1	0	1	0	1	0	1	1	Scroll Start Set	AB	1 byte
19	OSCON	0	1	0	1	1	0	1	0	0	0	1	Internal OSC on	D1	None
20	OSCOFF	0	1	0	1	1	0	1	0	0	1	0	Internal OSC off	D2	None
21	PWRCTRL	0	1	0	0	0	1	0	0	0	0	0	Power Control	20	1 byte
22	VOLCTRL	0	1	0	1	0	0	0	0	0	0	1	EC control	81	2 bytes
23	VOLUP	0	1	0	1	1	0	1	0	1	1	0	EC increase 1	D6	None
24	VOLDOWN	0	1	0	1	1	0	1	0	1	1	1	EC decrease 1	D7	None
25	RESERVED	0	1	0	1	0	0	0	0	0	1	0	Not Use	82	0
26	EPSRRD1	0	1	0	0	1	1	1	1	1	0	0	READ Register1	7C	None

27	EPSRRD2	0	1	0	0	1	1	1	1	1	0	1	READ Register2	7D	None
28	NOP	0	1	0	0	0	1	0	0	1	0	1	NOP Instruction	25	None
29	STREAD	0	0	1	Read Data							Status Read			

Ext=1

Index	Command	A0	RD	WR	D7	D6	D5	D4	D3	D2	D1	D0	Function	Hex	Parameter
1	Gray 1 Set	0	1	0	0	0	1	0	0	0	0	0	FRAME 1 Gray PWM Set	20	16 bytes
2	Gray 2 Set	0	1	0	0	0	1	0	0	0	0	1	FRAME 2 Gray PWM Set	21	16 bytes
3	ANASET	0	1	0	0	0	1	1	0	0	1	0	Analog Circuit Set	32	3 bytes
4	XARD	0	1	0	1	1	0	1	0	1	1	1	OTP Auto Read	D7	1 byte
5	XWRDC	0	1	0	1	1	1	0	0	0	0	0	OTP WR/RD Control	E0	1 byte
6	XCTRL	0	1	0	1	1	1	0	0	0	0	1	OTP Control Out	E1	None
7	XWR	0	1	0	1	1	1	0	0	0	1	0	OTP Write	E2	None
8	XRD	0	1	0	1	1	1	0	0	0	1	1	OTP Read	E3	None
9	XSC	0	1	0	1	1	1	0	0	1	0	0	OTP Selection Control	E4	1 byte
10	XPS	0	1	0	1	1	1	0	0	1	0	1	OTP Programming Setting	E5	1 byte

Ext=2

Index	Command	A0	RD	WR	D7	D6	D5	D4	D3	D2	D1	D0	Function	Hex	Parameter
1	EOTP	0	1	0	1	1	0	1	0	1	1	0	Enable OTP	D6	1 byte

11. ACCEPT QUALITY LEVEL (AQL)

11.1 Inspection Plan: ANSI Z-1.4, Normal Inspection Level II, Single Sampling Plan.

12. RELIABILITY TEST

Operating life time: 50000 hours

(at room temperature without direct irradiation of sunlight)

Reliability characteristics shall meet following requirements.

Test Item	Test Condition
High Temperature Storage	+80°C x 96hrs
Low Temperature Storage	-30°C x 96hrs
High Temperature Operation	+70°C x 96hrs
Low Temperature Operation	-20°C x 96hrs
High Temperature, High Humidity	+60°C x 95%RH x 96hrs
Thermal Shock	-20°C x 30min → +25°C x 10s → +70°C x 30min 5Cycles
Vibration Test	Frequency x Swing x Time 40Hz x 4mm x 4hrs
Drop Test	Drop height x No. of drops 1.0m x 6drops

13. QUALITY DESCRIPTION

DEFECT SPECIFICATION:

a: Table for Cosmetic defects

(Note: nc = not counted).
 Sizes and number of defects
 (Max. Qty)

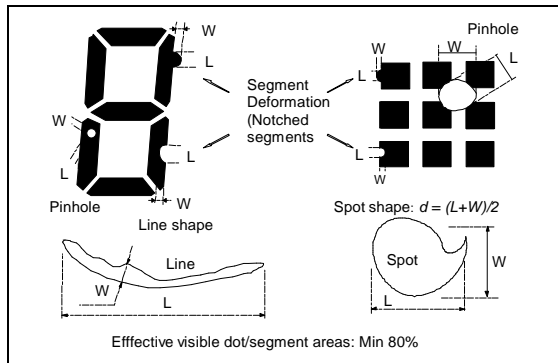

Examples/ Shapes

b: Glass defects

b1: Glass defects at contact ledge

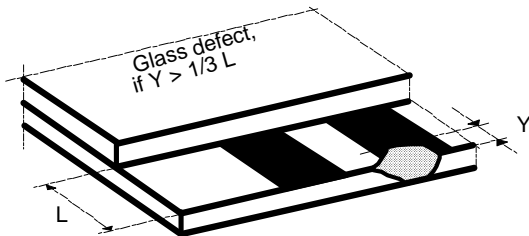

b2: Glass chipping in other areas shall not be in conflict with the product's function.

Defect Type	Max. defect size [mm] d or L W	Max. Quantity.
Black or White Spots	$d \leq 100$	nc
	$100 < d \leq 200$	3
Black or White Lines	--	$W \leq 10$
	$L \leq 3000$	$W \leq 30$
	$L \leq 2000$	$W \leq 50$
Pinhole	$d \leq 100$	nc
	$100 < d \leq 200$	1/segment
(Total defects)		(5)
Segment Deformation	$W \leq 100$	nc
Bubble (e.g. under pola)	$d \leq 150$	nc
	$200 < d \leq 400$	2

14. LCD MODULES HANDLING PRECAUTIONS

- n The display panel is made of glass. Do not subject it to a mechanical shock by dropping it from a high place, etc.
- n If the display panel is damaged and the liquid crystal substance inside it leaks out, do not get any in your mouth. If the substance comes into contact with your skin or clothes promptly wash it off using soap and water.
- n Do not apply excessive force to the display surface or the adjoining areas since this may cause the color tone to vary.
- n The polarizer covering the display surface of the LCD module is soft and easily scratched. Handle this polarizer carefully.
- n To prevent destruction of the elements by static electricity, be careful to maintain an optimum work environment.
 - Be sure to ground the body when handling the LCD module.
 - Tools required for assembly, such as soldering irons, must be properly grounded.
 - To reduce the amount of static electricity generated, do not conduct assembly and other work under dry conditions.
 - The LCD module is coated with a film to protect the display surface. Exercise care when peeling off this protective film since static electricity may be generated.

n Storage precautions

When storing the LCD modules, avoid exposure to direct sunlight or to the light of fluorescent lamps. Keep the modules in bags designed to prevent static electricity charging under low temperature / normal humidity conditions (avoid high temperature / high humidity and low temperatures below 0°C). Whenever possible, the LCD modules should be stored in the same conditions in which they were shipped from our company.

15. OTHERS

- n Liquid crystals solidify at low temperature (below the storage temperature range) leading to defective orientation of liquid crystal or the generation of air bubbles (black or white). Air bubbles may also be generated if the module is subjected to strong shock at a low temperature.
- n If the LCD modules have been operating for a long time showing the same display patterns may remain on the screen as ghost images and a slight contrast irregularity may also appear. Abnormal operating status can be resumed to be normal condition by suspending use for some time. It should be noted that this phenomenon does not adversely affect performance reliability.
- n To minimize the performance degradation of the LCD modules resulting from caused by static electricity, etc. exercise care to avoid holding the following sections when handling the modules :
 - Exposed area of the printed circuit board
 - Terminal electrode sections