

**Display Elektronik GmbH**

# DATA SHEET

***TFT MODULE***

**DEM 240320J4 TMH-PW-N**

**2,4" TFT**

**Product Specification**

**Ver.: 2**

**28.11.2023**

**Revision History**

<b>Revision</b>	<b>Date</b>	<b>Originator</b>	<b>Detail</b>	<b>Remarks</b>
0	15.06.2023	LQ	Initial Release	-
1	19.06.2023	LQ	Modify Reliability Specification Modify Outline Drawing(B)	P21 P24
2	28.11.2023	LQ	Modify Outline Drawing(C)	P24

**Table of Contents**

No.	Item	Page
1.	General Description .....	4
2.	Module Parameter .....	4
3.	Absolute Maximum Ratings .....	4
4.	DC Characteristics .....	5
5.	Backlight Characteristic .....	5
5.1.	Backlight Characteristics.....	5
5.2.	Backlighting Circuit .....	5
6.	Optical Characteristics .....	6
6.1.	Optical Characteristics .....	6
6.2.	Definition of Response Time .....	6
6.3.	Definition of Contrast Ratio .....	7
6.4.	Definition of Viewing Angles.....	7
6.5.	Definition of Color Appearance .....	8
6.6.	Definition of Surface Luminance, Uniformity and Transmittance.....	8
7.	Block Diagram and Power Supply .....	9
8.	Interface Pins Definition .....	9
9.	AC Characteristics .....	11
9.1.	8080 MCU 8-bit/16-bit Interface Timing Characteristics .....	11
9.2.	Serial interface characteristics .....	12
9.3.	Reset timing .....	14
10.	Quality Assurance .....	15
10.1.	Purpose .....	15
10.2.	Standard for Quality Test.....	15
10.3.	Nonconforming Analysis & Disposition .....	15
10.4.	Agreement Items.....	15
10.5.	Standard of the Product Visual Inspection .....	16
10.6.	Inspection Specification .....	16
10.7.	Classification of Defects.....	19
10.8.	Identification/marketing criteria .....	19
10.9.	Packaging .....	20
11.	Reliability Specification .....	21
12.	Precautions and Warranty .....	22
12.1.	Safety .....	22
12.2.	Handling .....	22
12.3.	Storage.....	22
12.4.	Metal Pin (Apply to Products with Metal Pins) .....	22
12.5.	Operation .....	23
12.6.	Static Electricity .....	23
12.7.	Limited Warranty .....	23
13.	Outline Drawing .....	24

## 1. General Description

The specification is a transmissive type color active matrix liquid crystal display (LCD) which uses amorphous thin film transistor (TFT) as switching devices. This product is composed of a TFT-LCD panel, driver ICs and a backlight unit.

## 2. Module Parameter

Features	Details	Unit
Display Size(Diagonal)	2.4"	-
LCD type	TN TFT	-
Display Mode	Transmissive / Normally White	-
Resolution	240 x RGB x 320	Pixels
View Direction	6 O'clock	Best Image
Gray Scale Inversion Direction	12 O'clock	-
Module Outline	42.72 x 60.26 x 2.65 (Note 1 )	mm
Active Area	36.72 x 48.96	mm
Pixel Size	0.153 x 0.153	mm
Pixel Arrangement	Stripe	-
Polarizer Surface Treatment	Anti-glare	-
Display Colors	262K	-
Interface	16/8 Bit Bus Interface 3/4 Wire Serial Interface	-
With or without touch panel	Without	-
Driver IC	ST7789T3 (Sitronix)	-
Operating Temperature	-20°C to +70°C	°C
Storage Temperature	-30°C to +80°C	°C
Weight	~ 10	g

Note 1: Exclusive hooks, posts, FFC/FPC tail etc.

## 3. Absolute Maximum Ratings

$V_{SS} = 0V, T_a = 25^\circ C$

Item	Symbol	Min.	Max.	Unit
Supply Voltage	VCC	-0.3	4.6	V
	VCI	-0.3	4.6	V
Storage Temperature	T <sub>STG</sub>	-30	+80	°C
Operating Temperature	T <sub>OP</sub>	-20	+70	°C

Note 1: If  $T_a$  below 50°C, the maximal humidity is 90%RH, if  $T_a$  over 50°C, absolute humidity should be less than 60%RH.

Note 2: The response time will be extremely slow when the operating temperature is around -10°C, and the back ground will become darker at high temperature operating.

4. DC Characteristics

Item	Symbol	Min.	Typ.	Max.	Unit	
Supply Voltage	VCC	2.4	2.8	3.3	V	
	VCI	1.65	1.8	3.3	V	
Logic Low Input Voltage	V <sub>IL</sub>	GND	-	0.3*VCI	V	
Logic High Input Voltage	V <sub>IH</sub>	0.7*VCI	-	VCI	V	
Logic Low Output Voltage	V <sub>OL</sub>	GND	-	0.2*VCI	V	
Logic High Output Voltage	V <sub>OH</sub>	0.8*VCI	-	VCI	V	
Current Consumption All White	Logic	I <sub>CC+ IIN</sub>	-	8	-	mA
	Analog					

5. Backlight Characteristic

5.1. Backlight Characteristics

Item	Symbol	Condition	Min.	Typ.	Max.	Unit
Forward Voltage	V <sub>F</sub>	Ta=25 °C, I <sub>F</sub> =15mA/LED	2.8	3.1	3.3	V
Forward Current	I <sub>F</sub>	Ta=25 °C, V <sub>F</sub> =3.1V/LED	-	60	-	mA
Power Dissipation	P <sub>D</sub>		-	186	-	mW
Uniformity	Avg		-	80	-	%
LED Lifetime (25°C)	-		-	50,000	-	Hrs
Drive Method	Constant Current					
LED brand	Nichia					
LED Configuration	4 White LEDs in Parallel					

Note1: LED life time defined as follows: The final brightness is at 50% of original brightness.  
The environmental conducted under ambient air flow, at Ta=25°C±2 °C, 60%RH±5%, I<sub>F</sub>=15mA

5.2. Backlighting Circuit

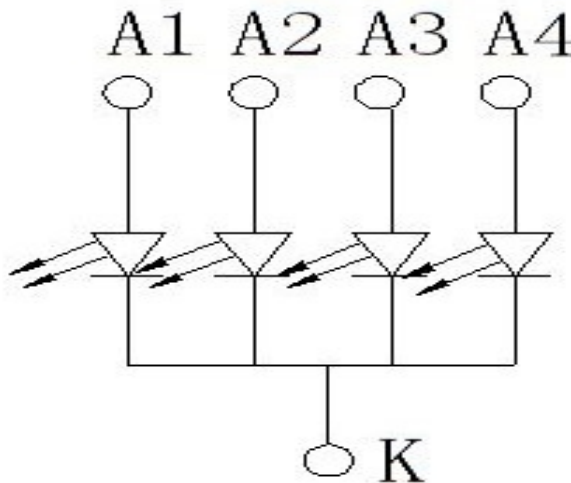

6. Optical Characteristics

6.1. Optical Characteristics

Ta=25°C, VCC=2.8V

	Item	Symbol	Condition	Specification			Unit	
				Min.	Typ.	Max.		
Backlight On (Transmissive Mode)	Luminance on TFT ( $I_f=15\text{mA/LED}$ )	Lv	Normally viewing angle $\theta_X = \phi_Y = 0^\circ$	250	320	-	cd/m <sup>2</sup>	
	Contrast ratio(See 6.3)	CR			250	-		
	Response Time (See 6.2)	TR+TF		-	30	-	ms	
	Chromaticity Transmissive (See 6.5)	Red	XR	Center CR≥10	0.547	0.597	0.647	
			YR		0.288	0.338	0.388	
		Green	XG		0.267	0.317	0.367	
			YG		0.585	0.635	0.685	
		Blue	XB		0.096	0.146	0.196	
			YB		0.031	0.081	0.131	
	White	XW	0.250	0.300	0.350			
		YW	0.292	0.342	0.392			
	Viewing Angle (See 6.4)	Horizontal	$\theta_{X+}$	Center CR≥10	55	70	-	Deg.
$\theta_{X-}$			55		70	-		
Vertical		$\phi_{Y+}$	55		70	-		
		$\phi_{Y-}$	35		50	-		
NTSC Ratio(Gamut)				-	-	55	-	

6.2. Definition of Response Time

6.2.1. Normally Black Type (Negative)

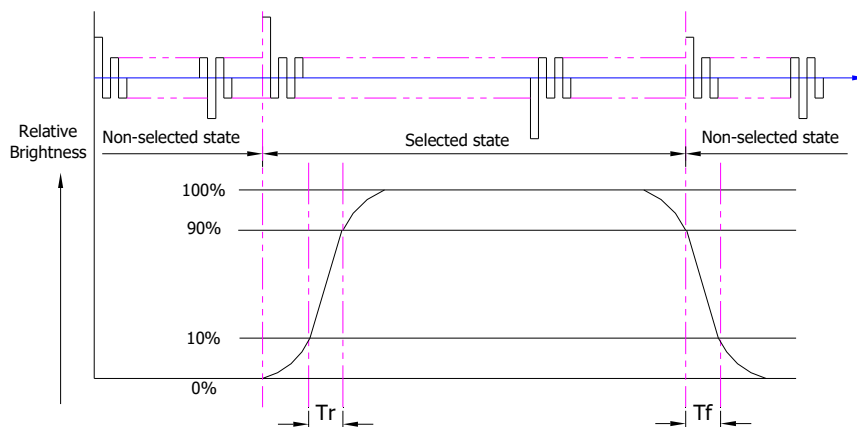

Tr is the time it takes to change form non-selected stage with relative luminance 10% to selected state with relative luminance 90%;

Tf is the time it takes to change from selected state with relative luminance 90% to non-selected state with relative luminance 10%.

Note: Measuring machine: LCD-5100

6.2.2. Normally White Type (Positive)

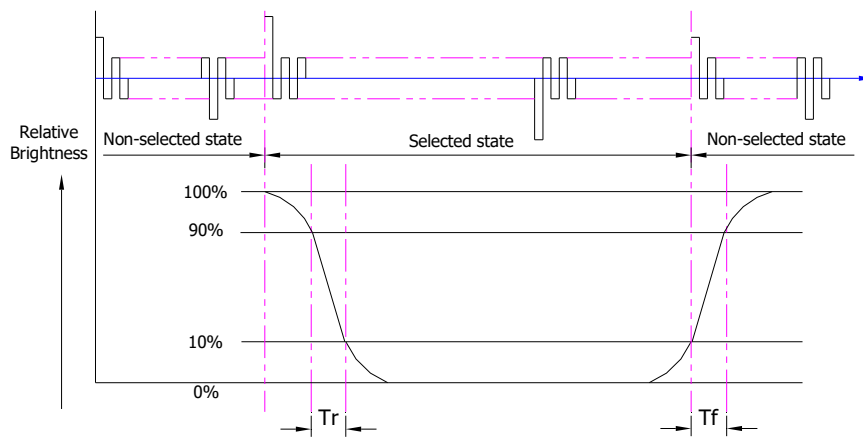

Tr is the time it takes to change from non-selected stage with relative luminance 90% to selected state with relative luminance 10%;

Tf is the time it takes to change from selected state with relative luminance 10% to non-selected state with relative luminance 90%;

Note: Measuring machine: LCD-5100 or EQUI

6.3. Definition of Contrast Ratio

Contrast is measured perpendicular to display surface in reflective and transmissive mode. The measurement condition is:

Measuring Equipment	Eldim or Equivalent
Measuring Point Diameter	3mm//1mm
Measuring Point Location	Active Area centre point
Test Pattern	A: All Pixels white
	B: All Pixel black
Contrast Setting	Maximum

Definitions: CR (Contrast) = Luminance of White Pixel / Luminance of Black Pixel

6.4. Definition of Viewing Angles

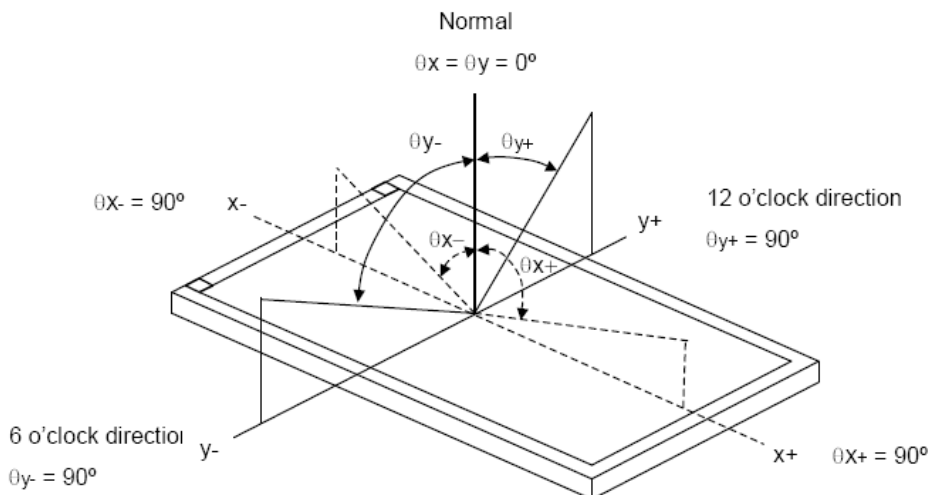

Measuring machine: LCD-5100 or EQUI

**6.5. Definition of Color Appearance**

R,G,B and W are defined by (x, y) on the IE chromaticity diagram

NTSC=area of RGB triangle/area of NTSC triangleX100%

Measuring picture: Red, Green, Blue and White (Measuring machine: BM-7)

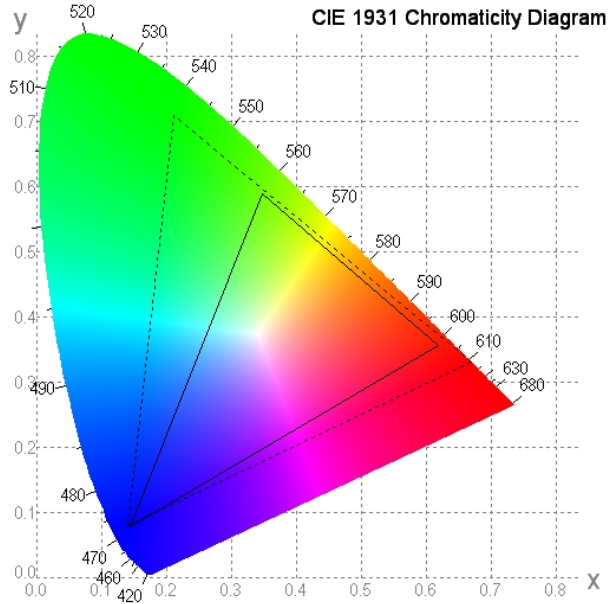

**6.6. Definition of Surface Luminance, Uniformity and Transmittance**

Using the transmissive mode measurement approach, measure the white screen luminance of the display panel and backlight.

6.6.1. Surface Luminance:  $L_v = \text{average} (L_{P1}:L_{P9})$

6.6.2. Uniformity =  $\text{Minimal} (L_{P1}:L_{P9}) / \text{Maximal} (L_{P1}:L_{P9}) * 100\%$

6.6.3. Transmittance =  $L_v \text{ on LCD} / L_v \text{ on Backlight} * 100\%$

Note: Measuring machine: BM-7

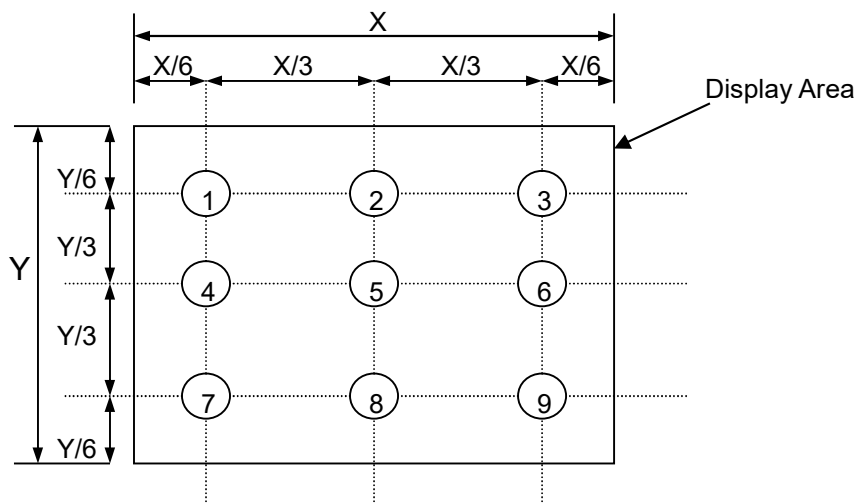



7. Block Diagram and Power Supply

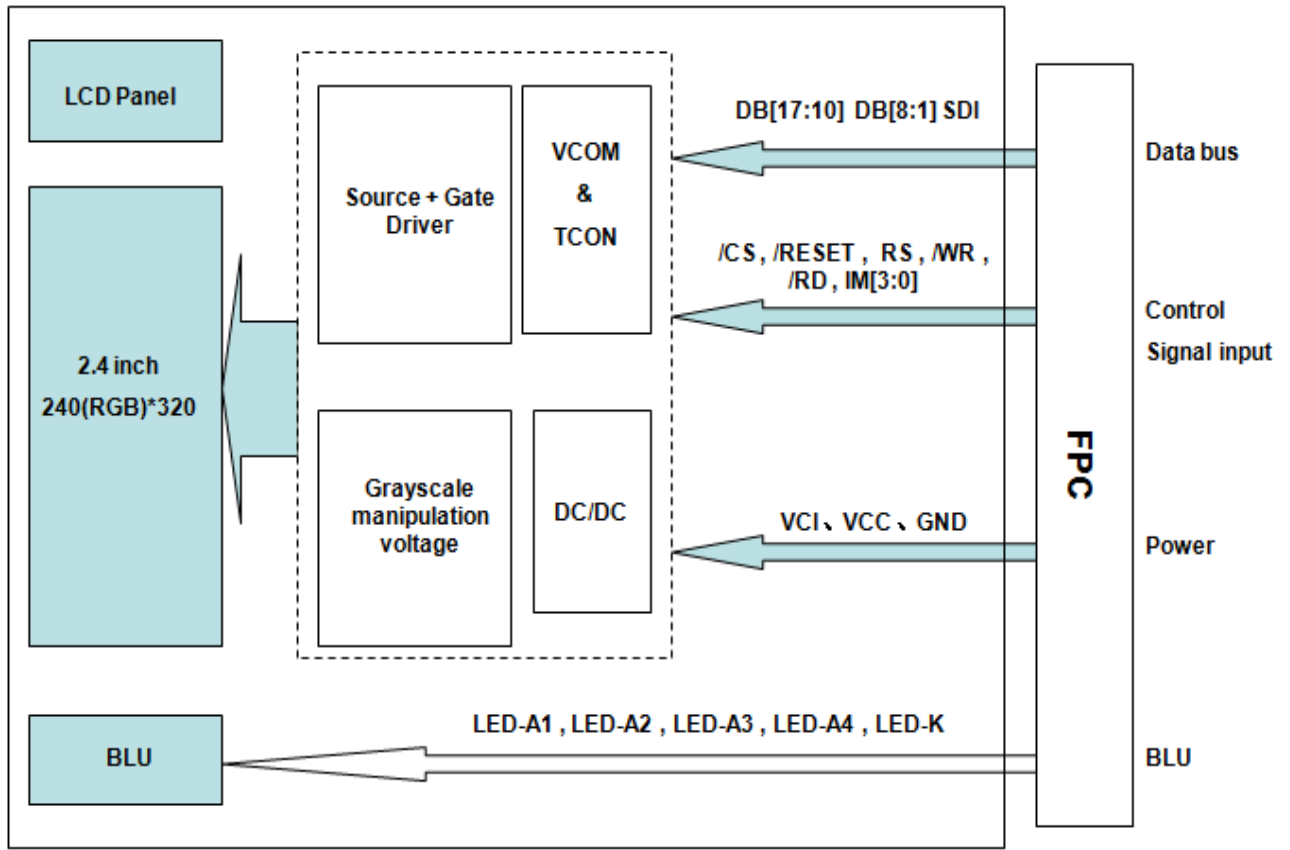

8. Interface Pins Definition

No.	Symbol	Function	Remark
1	DB10	Data bus	
2	DB11	Data bus	
3	DB12	Data bus	
4	DB13	Data bus	
5	GND	Ground	
6	VCC	Power Supply	
7	/CS	Chip Select Signal CSX=/CS	
8	RS	- Display Data/Command selection pin in parallel interface - This pin is used to be serial interface clock - D/CX=DCX=RS	DCX pin
9	/WR	- Write enable in MCU parallel interface - Display data/command selection pin in 4-line serial interface - WRX=/WR	

10	/RD	- Read enable in 8080 MCU parallel interface - If not used, please fix this pin at VDDI or DGND - RDX=/RD	
11	IM0	MCU interface mode select	NOTE1
12	IM3	MCU interface mode select	NOTE1
13	IM2	MCU interface mode select	NOTE1
14	SDI	SPI interface input pin	
15	SDO	SPI interface output pin.	
16	NC	No connection	
17	NC	No connection	
18	NC	No connection	
19	NC	No connection	
20	LED-K	Led cathode	
21	LED-A1	Led anode-1	
22	LED-A2	Led anode-2	
23	LED-A3	Led anode-3	
24	LED-A4	Led anode-4	
25	DB14	Data bus	
26	DB1	Data bus	
27	DB2	Data bus	
28	DB3	Data bus	
29	DB4	Data bus	
30	DB5	Data bus	
31	DB6	Data bus	
32	DB7	Data bus	
33	DB8	Data bus	
34	/RESET	Reset signal	
35	VCI	Power supply	
36	VCC	Power supply	
37	IM1	MCU interface mode select	NOTE1
38	DB15	Data bus	
39	DB16	Data bus	
40	DB17	Data bus	

NOTE1:

IM3	IM2	IM1	IM0	MCU-Interface Mode	DB Pin in use
1	0	0	0	80 MCU 16-bit bus interface II	D[17:10],D[8:1]
1	0	0	1	80 MCU 8-bit bus interface II	D[17:10]
1	1	0	1	3-wire 9-bit date serial interface II	SDI:In/SDO:OUT
1	1	1	0	4-wire 8-bit date serial interface II	SDI:In/SDO:OUT

9. AC Characteristics

9.1. 8080 MCU 8-bit/16-bit Interface Timing Characteristics

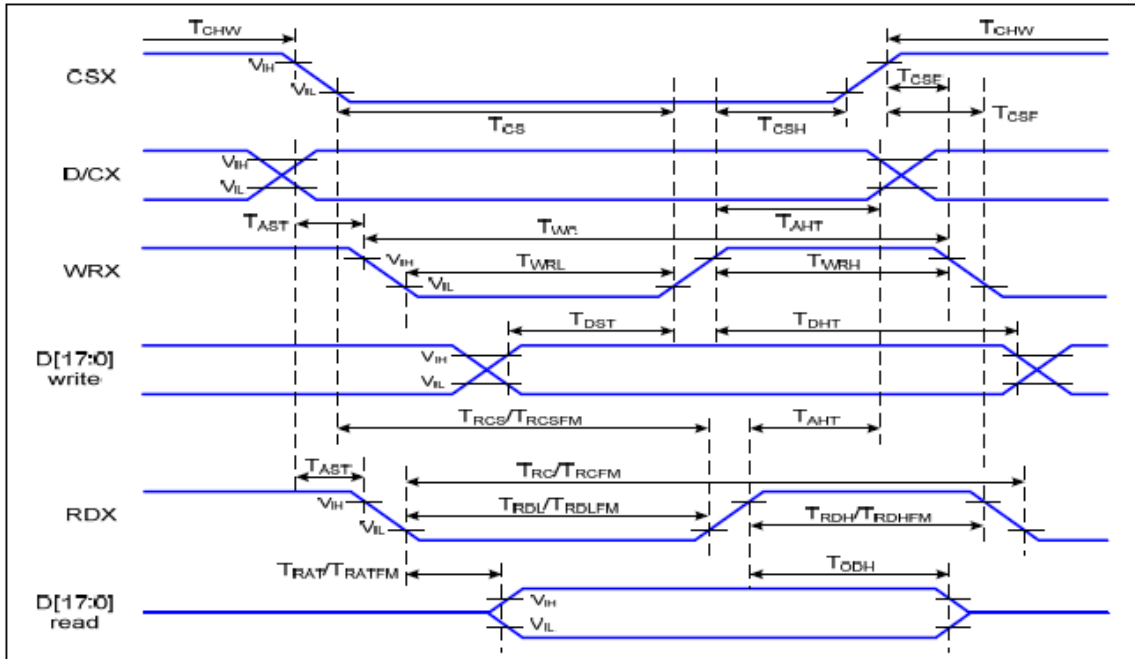

Signal	Symbol	Parameter	Min	Max	Unit	Description
D/CX	T <sub>AST</sub>	Address setup time	0		ns	
	T <sub>AHT</sub>	Address hold time (Write/Read)	10		ns	
CSX	T <sub>CHW</sub>	Chip select "H" pulse width	0		ns	
	T <sub>CS</sub>	Chip select setup time (Write)	15		ns	
	T <sub>RCS</sub>	Chip select setup time (Read ID)	45		ns	
	T <sub>RCSFM</sub>	Chip select setup time (Read FM)	355		ns	
	T <sub>CSF</sub>	Chip select wait time (Write/Read)	10		ns	
	T <sub>CSH</sub>	Chip select hold time	10		ns	
WRX	T <sub>WC</sub>	Write cycle	66		ns	
	T <sub>WRH</sub>	Control pulse "H" duration	15		ns	
	T <sub>WRL</sub>	Control pulse "L" duration	15		ns	
RDX (ID)	T <sub>RC</sub>	Read cycle (ID)	160		ns	When read ID data
	T <sub>RDH</sub>	Control pulse "H" duration (ID)	90		ns	
	T <sub>RDL</sub>	Control pulse "L" duration (ID)	45		ns	
RDX (FM)	T <sub>RCFM</sub>	Read cycle (FM)	450		ns	When read from frame memory
	T <sub>RDHFM</sub>	Control pulse "H" duration (FM)	90		ns	
	T <sub>RDLFM</sub>	Control pulse "L" duration (FM)	355		ns	
D[17:0]	T <sub>DST</sub>	Data setup time	10		ns	For CL=30pF
	T <sub>DHT</sub>	Data hold time	10		ns	
	T <sub>RAT</sub>	Read access time (ID)		40	ns	
	T <sub>RATFM</sub>	Read access time (FM)		340	ns	
	T <sub>ODH</sub>	Output disable time	20	80	ns	

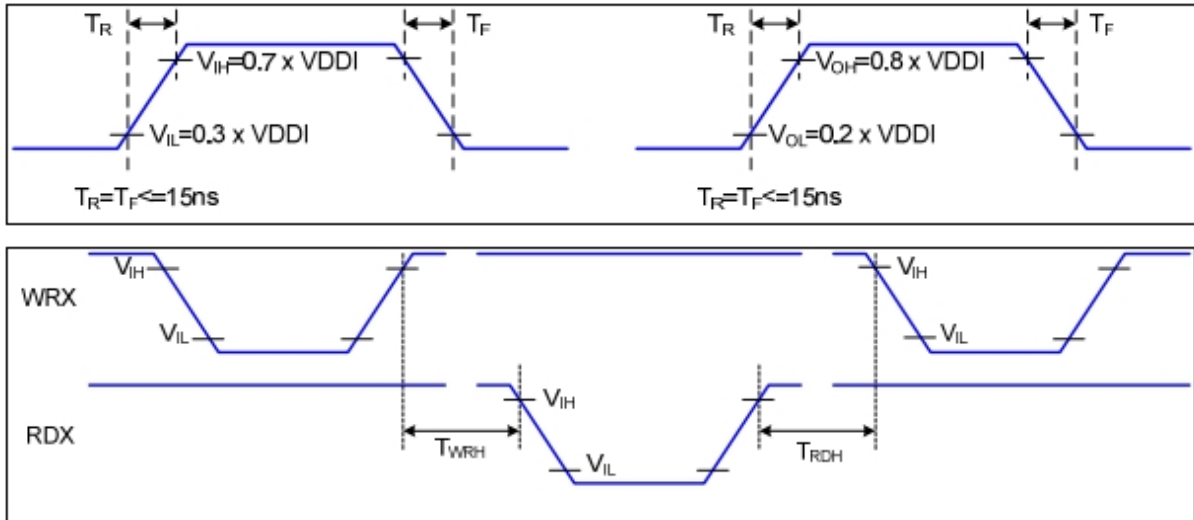

9.2. Serial interface characteristics

9.2.1 3-line serial

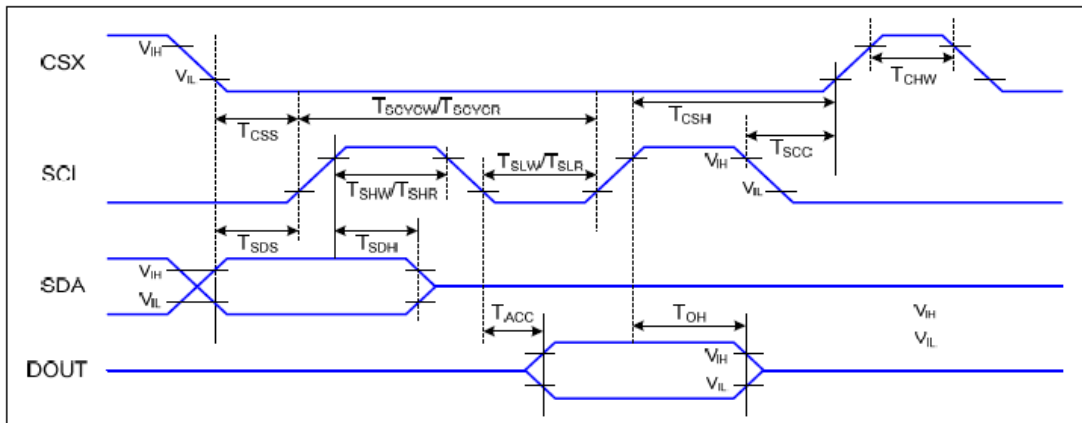

Signal	Symbol	Parameter	Min	Max	Unit	Description
CSX	$T_{CSS}$	Chip select setup time (write)	15		ns	
	$T_{CSH}$	Chip select hold time (write)	15		ns	
	$T_{CSS}$	Chip select setup time (read)	60		ns	
	$T_{SCC}$	Chip select hold time (read)	65		ns	
	$T_{CHW}$	Chip select "H" pulse width	40		ns	
SCL	$T_{SCYCW}$	Serial clock cycle (Write)	66		ns	
	$T_{SHW}$	SCL "H" pulse width (Write)	15		ns	
	$T_{SLW}$	SCL "L" pulse width (Write)	15		ns	
	$T_{SCYCR}$	Serial clock cycle (Read)	150		ns	
	$T_{SHR}$	SCL "H" pulse width (Read)	60		ns	
	$T_{SLR}$	SCL "L" pulse width (Read)	60		ns	
SDA (DIN)	$T_{SDS}$	Data setup time	10		ns	
	$T_{SDH}$	Data hold time	10		ns	
DOUT	$T_{ACC}$	Access time	10	50	ns	For maximum CL=30pF
	$T_{OH}$	Output disable time	15	50	ns	For minimum CL=8pF

9.2.2 4-line serial

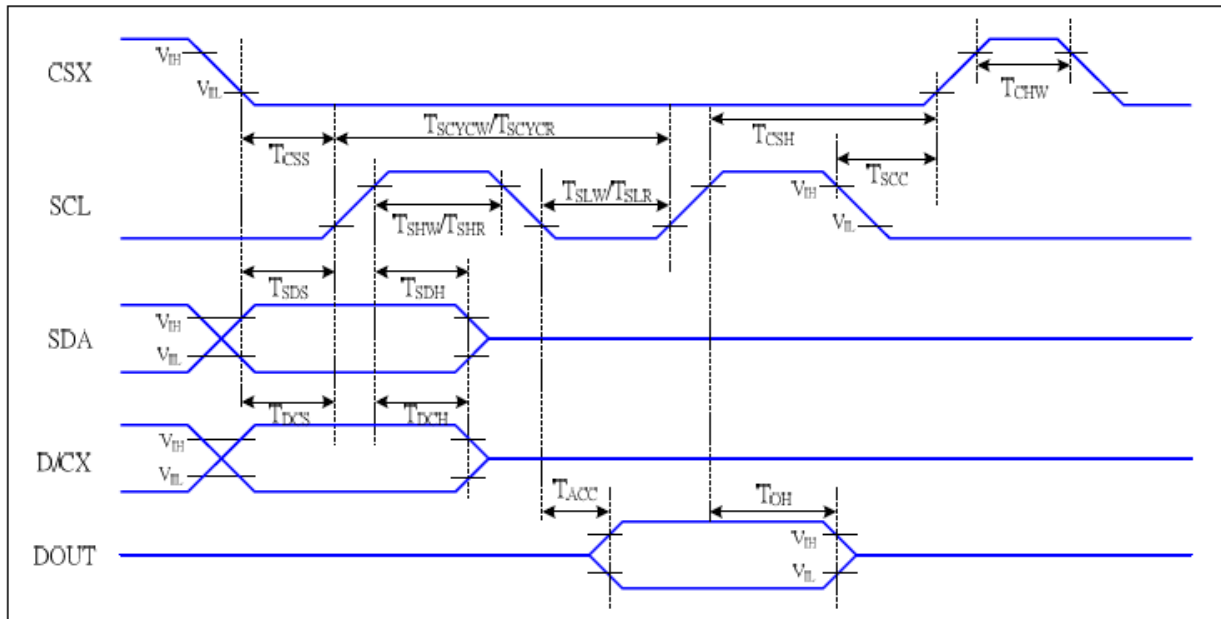

Signal	Symbol	Parameter	MIN	MAX	Unit	Description
CSX	T <sub>css</sub>	Chip select setup time (write)	15		ns	
	T <sub>sch</sub>	Chip select hold time (write)	15		ns	
	T <sub>css</sub>	Chip select setup time (read)	60		ns	
	T <sub>scc</sub>	Chip select hold time (read)	65		ns	
	T <sub>ch</sub>	Chip select "H" pulse width	40		ns	
SCL	T <sub>scyw</sub>	Serial clock cycle (Write)	66		ns	-write command & data ram
	T <sub>shw</sub>	SCL "H" pulse width (Write)	15		ns	
	T <sub>slw</sub>	SCL "L" pulse width (Write)	15		ns	
	T <sub>scy</sub>	Serial clock cycle (Read)	150		ns	-read command & data ram
	T <sub>shr</sub>	SCL "H" pulse width (Read)	60		ns	
	T <sub>slr</sub>	SCL "L" pulse width (Read)	60		ns	
D/CX	T <sub>dcs</sub>	D/CX setup time	10		ns	
	T <sub>dch</sub>	D/CX hold time	10		ns	
SDA (DIN)	T <sub>sd</sub>	Data setup time	10		ns	
	T <sub>sdh</sub>	Data hold time	10		ns	
DOUT	T <sub>acc</sub>	Access time	10	50	ns	For maximum CL=30pF
	T <sub>oh</sub>	Output disable time	15	50	ns	For minimum CL=8pF

9.3. Reset Timing

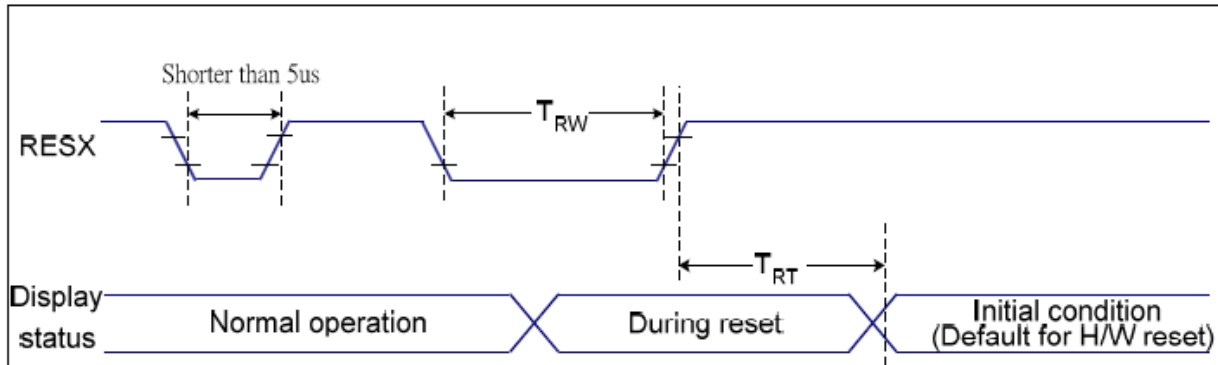

Related Pins	Symbol	Parameter	MIN	MAX	Unit
RESX	TRW	Reset pulse duration	10	-	us
	TRT	Reset cancel	-	5 (Note 1, 5)	ms
				120 (Note 1, 6, 7)	ms

Notes:

1. The reset cancel includes also required time for loading ID bytes, VCOM setting and other settings from NVM (or similar device) to registers. This loading is done every time when there is HW reset cancel time (tRT) within 5 ms after a rising edge of RESX.

2. Spike due to an electrostatic discharge on RESX line does not cause irregular system reset according to the table below:

RESX Pulse	Action
Shorter than 5us	Reset Rejected
Longer than 9us	Reset
Between 5us and 9us	Reset starts

3. During the Resetting period, the display will be blanked (The display is entering blanking sequence, which maximum time is 120 ms, when Reset Starts in Sleep Out –mode. The display remains the blank state in Sleep In –mode.) and then return to Default condition for Hardware Reset.

4. Spike Rejection also applies during a valid reset pulse as shown below:

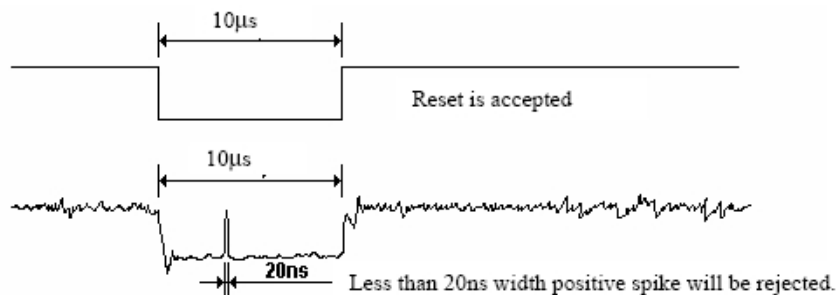

5. When Reset applied during Sleep In Mode.

6. When Reset applied during Sleep Out Mode.

7. It is necessary to wait 5msec after releasing RESX before sending commands. Also Sleep Out command cannot be sent for 120msec.

## **10. Quality Assurance**

### **10.1. Purpose**

This standard for Quality Assurance assures the quality of LCD module products supplied to customer.

### **10.2. Standard for Quality Test**

#### 10.2.1. Sampling Plan:

GB2828.1-2012

Single sampling, general inspection level II

#### 10.2.2. Sampling Criteria:

Visual inspection: AQL 1.5

Electrical functional: AQL 0.65.

#### 10.2.3. Reliability Test:

Detailed requirement refer to Reliability Test Specification.

### **10.3. Nonconforming Analysis & Disposition**

#### 10.3.1. Nonconforming analysis:

10.3.1.1. Customer should provide overall information of non-conforming sample for their complaints.

10.3.1.2. After receipt of detailed information from customer, the analysis of nonconforming parts usually should be finished in one week.

10.3.1.3. If cannot finish the analysis on time, customer will be notified with the progress status.

#### 10.3.2. Disposition of nonconforming:

10.3.2.1. Non-conforming product over PPM level will be replaced.

10.3.2.2. The cause of non-conformance will be analyzed. Corrective action will be discussed and implemented.

### **10.4. Agreement Items**

Shall negotiate with customer if the following situation occurs:

10.4.1. There is any discrepancy in standard of quality assurance.

10.4.2. Additional requirement to be added in product specification.

10.4.3. Any other special problem.

10.5. Standard of the Product Visual Inspection

10.5.1. Appearance inspection:

10.5.1.1. The inspection must be under illumination about 1000 – 1500 lx, and the distance of view must be at 30cm ± 2cm.

10.5.1.2. The viewing angle should be 45° from the vertical line without reflection light or follows customer's viewing angle specifications.

10.5.1.3. Definition of area: A Zone: Active Area, B Zone: Viewing Area,

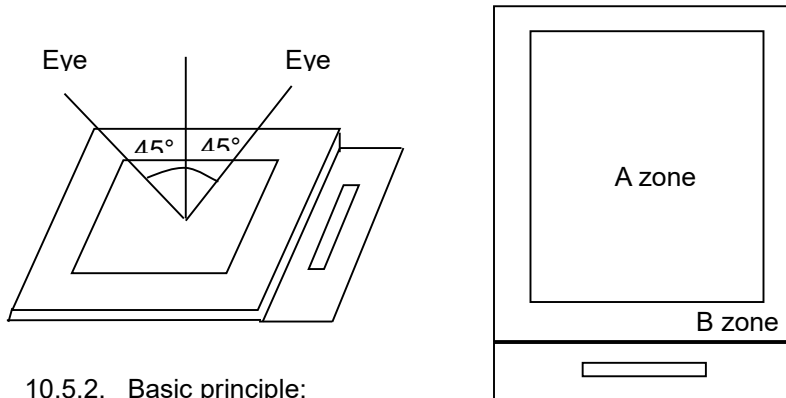

10.5.2. Basic principle:

10.5.2.1. A set of sample to indicate the limit of acceptable quality level must be discussed by both us and customer when there is any dispute happened.

10.5.2.2. New item must be added on time when it is necessary.

10.6. Inspection Specification

No.	Item	Criteria (Unit: mm)																		
01	Black / White spot Foreign material (Round type) Pinholes Stain Particles inside cell. (Minor defect)	$\phi = (a + b) / 2$ <p>Distance between 2 defects should more than 3mm apart.</p>	<table border="1"> <thead> <tr> <th>Size \ Area</th> <th>Acc. Qty</th> </tr> </thead> <tbody> <tr> <td><math>\phi \leq 0.10</math></td> <td>Ignore</td> </tr> <tr> <td><math>0.10 &lt; \phi \leq 0.2</math></td> <td>2</td> </tr> <tr> <td><math>0.2 &lt; \phi \leq 0.3</math></td> <td>1</td> </tr> <tr> <td><math>0.25 &lt; \phi</math></td> <td>0</td> </tr> <tr> <td>Total</td> <td>2 no include <math>\phi \leq 0.10</math></td> </tr> </tbody> </table>		Size \ Area	Acc. Qty	$\phi \leq 0.10$	Ignore	$0.10 < \phi \leq 0.2$	2	$0.2 < \phi \leq 0.3$	1	$0.25 < \phi$	0	Total	2 no include $\phi \leq 0.10$				
			Size \ Area	Acc. Qty																
$\phi \leq 0.10$	Ignore																			
$0.10 < \phi \leq 0.2$	2																			
$0.2 < \phi \leq 0.3$	1																			
$0.25 < \phi$	0																			
Total	2 no include $\phi \leq 0.10$																			
02	Electrical Defect (Minor defect)	<table border="1"> <thead> <tr> <th></th> <th>Display Area</th> <th>Total</th> <th></th> </tr> </thead> <tbody> <tr> <td>Bright dot</td> <td><math>N \leq 1</math></td> <td><math>N \leq 1</math></td> <td rowspan="3">Note1</td> </tr> <tr> <td>Dark dot</td> <td><math>N \leq 2</math></td> <td><math>N \leq 2</math></td> </tr> <tr> <td>Total dot</td> <td><math>N \leq 2</math></td> <td><math>N \leq 2</math></td> </tr> <tr> <td>Mura</td> <td colspan="2">Not visible through 5% ND filters.</td> <td>Note2</td> </tr> </tbody> </table> <p>Remark: 1. Bright dot caused by scratch and foreign object accords to item</p>		Display Area	Total		Bright dot	$N \leq 1$	$N \leq 1$	Note1	Dark dot	$N \leq 2$	$N \leq 2$	Total dot	$N \leq 2$	$N \leq 2$	Mura	Not visible through 5% ND filters.		Note2
	Display Area	Total																		
Bright dot	$N \leq 1$	$N \leq 1$	Note1																	
Dark dot	$N \leq 2$	$N \leq 2$																		
Total dot	$N \leq 2$	$N \leq 2$																		
Mura	Not visible through 5% ND filters.		Note2																	

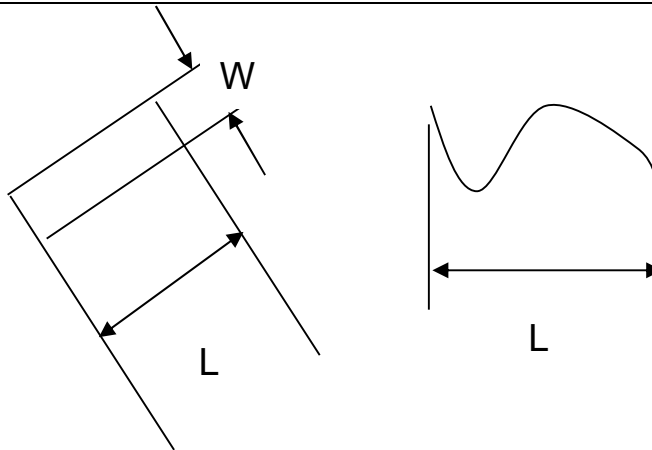
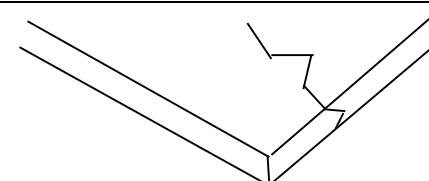
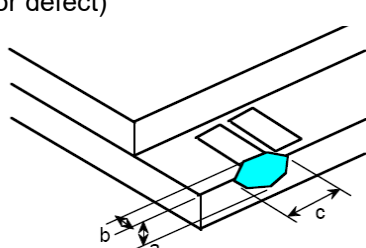
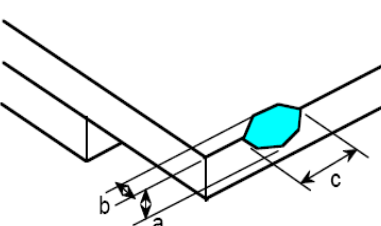

<p>03</p>	<p>Black and White line Scratch Foreign material (Line type) (Minor defect)</p>	 <table border="1" data-bbox="478 638 1109 896"> <thead> <tr> <th>Length</th> <th>Width</th> <th>Acc. Qty</th> </tr> </thead> <tbody> <tr> <td>/</td> <td><math>W \leq 0.03</math></td> <td>Ignore</td> </tr> <tr> <td><math>L \leq 5</math></td> <td><math>0.03 &lt; W \leq 0.1</math></td> <td>1</td> </tr> <tr> <td>/</td> <td><math>0.1 &lt; W</math></td> <td>0</td> </tr> <tr> <td colspan="2">Total</td> <td>3</td> </tr> </tbody> </table> <p>Distance between 2 defects should more than 3mm apart. Scratches not viewable through the back of the display are acceptable.</p>	Length	Width	Acc. Qty	/	$W \leq 0.03$	Ignore	$L \leq 5$	$0.03 < W \leq 0.1$	1	/	$0.1 < W$	0	Total		3
Length	Width	Acc. Qty															
/	$W \leq 0.03$	Ignore															
$L \leq 5$	$0.03 < W \leq 0.1$	1															
/	$0.1 < W$	0															
Total		3															
<p>04</p>	<p>Glass Crack (Minor defect)</p>	 <p>Crack is potential to enlarge, any type is not allowed.</p>															
<p>05</p>	<p>Glass Chipping Pad Area: (Minor defect)</p> 	<table border="1" data-bbox="861 1310 1332 1489"> <thead> <tr> <th>Length and Width</th> <th>Acc. Qty</th> </tr> </thead> <tbody> <tr> <td><math>c &gt; 3.0, b &lt; 1.0</math></td> <td>1</td> </tr> <tr> <td><math>c &lt; 3.0, b &lt; 1.0</math></td> <td>3</td> </tr> <tr> <td colspan="2">a &lt; Glass Thickness</td> </tr> </tbody> </table>	Length and Width	Acc. Qty	$c > 3.0, b < 1.0$	1	$c < 3.0, b < 1.0$	3	a < Glass Thickness								
Length and Width	Acc. Qty																
$c > 3.0, b < 1.0$	1																
$c < 3.0, b < 1.0$	3																
a < Glass Thickness																	
<p>06</p>	<p>Glass Chipping Rear of Pad Area: (Minor defect)</p> 	<table border="1" data-bbox="861 1646 1332 1870"> <thead> <tr> <th>Length and Width</th> <th>Acc. Qty</th> </tr> </thead> <tbody> <tr> <td><math>c &gt; 3.0, b &lt; 1.0</math></td> <td>1</td> </tr> <tr> <td><math>c &lt; 3.0, b &lt; 1.0</math></td> <td>2</td> </tr> <tr> <td><math>c &lt; 3.0, b &lt; 0.5</math></td> <td>4</td> </tr> <tr> <td colspan="2">a &lt; Glass Thickness</td> </tr> </tbody> </table>	Length and Width	Acc. Qty	$c > 3.0, b < 1.0$	1	$c < 3.0, b < 1.0$	2	$c < 3.0, b < 0.5$	4	a < Glass Thickness						
Length and Width	Acc. Qty																
$c > 3.0, b < 1.0$	1																
$c < 3.0, b < 1.0$	2																
$c < 3.0, b < 0.5$	4																
a < Glass Thickness																	

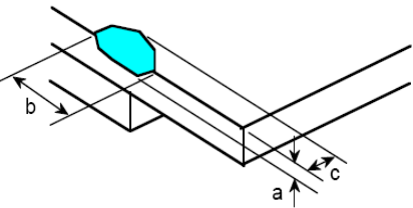
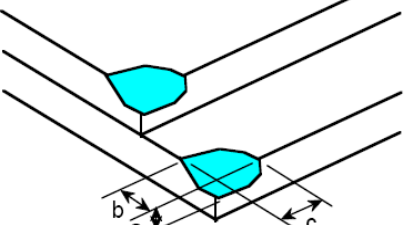
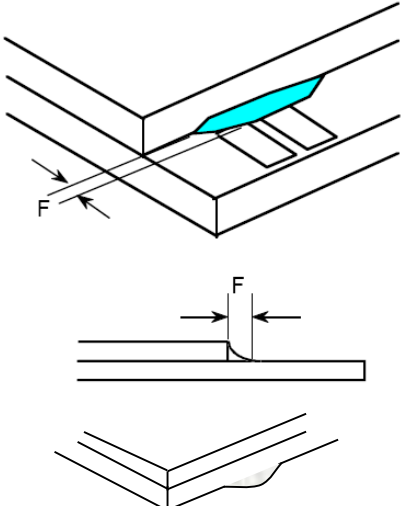
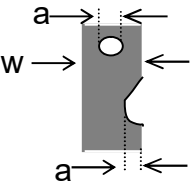
<p>07</p>	<p>Glass Chipping Except Pad Area: (Minor defect)</p> 	<table border="1"> <thead> <tr> <th>Length and Width</th> <th>Acc. Qty</th> </tr> </thead> <tbody> <tr> <td><math>c &gt; 3.0, b &lt; 1.0</math></td> <td>1</td> </tr> <tr> <td><math>c &lt; 3.0, b &lt; 1.0</math></td> <td>2</td> </tr> <tr> <td><math>c &lt; 3.0, b &lt; 0.5</math></td> <td>4</td> </tr> <tr> <td colspan="2" style="text-align: center;"><math>a &lt; \text{Glass Thickness}</math></td> </tr> </tbody> </table>	Length and Width	Acc. Qty	$c > 3.0, b < 1.0$	1	$c < 3.0, b < 1.0$	2	$c < 3.0, b < 0.5$	4	$a < \text{Glass Thickness}$	
Length and Width	Acc. Qty											
$c > 3.0, b < 1.0$	1											
$c < 3.0, b < 1.0$	2											
$c < 3.0, b < 0.5$	4											
$a < \text{Glass Thickness}$												
<p>08</p>	<p>Glass Corner Chipping: (Minor defect)</p> 	<table border="1"> <thead> <tr> <th>Length and Width</th> <th>Acc. Qty</th> </tr> </thead> <tbody> <tr> <td><math>c &lt; 3.0, b &lt; 3.0</math></td> <td>Ignore</td> </tr> <tr> <td colspan="2" style="text-align: center;"><math>a &lt; \text{Glass Thickness}</math></td> </tr> </tbody> </table>	Length and Width	Acc. Qty	$c < 3.0, b < 3.0$	Ignore	$a < \text{Glass Thickness}$					
Length and Width	Acc. Qty											
$c < 3.0, b < 3.0$	Ignore											
$a < \text{Glass Thickness}$												
<p>09</p>	<p>Glass Burr: (Minor defect)</p> 	<table border="1"> <thead> <tr> <th>Length</th> <th>Acc. Qty</th> </tr> </thead> <tbody> <tr> <td><math>F &lt; 1.0</math></td> <td>Ignore</td> </tr> </tbody> </table> <p>Glass burr don't affect assemble and module dimension.</p>	Length	Acc. Qty	$F < 1.0$	Ignore						
Length	Acc. Qty											
$F < 1.0$	Ignore											
<p>10</p>	<p>FPC Defect: (Minor defect)</p> 	<p>10.1 Dent, pinhole width <math>a &lt; w/3</math>. (w: circuitry width.)</p> <p>10.2 Open circuit is unacceptable.</p> <p>10.3 No oxidation, contamination and distortion.</p>										

11	Bubble on Polarizer (Minor defect)	<b>Diameter</b>		<b>Acc. Qty</b>	
		$\varphi \leq 0.20$		Ignore	
		$0.20 < \varphi \leq 0.30$		4	
		$0.30 < \varphi \leq 0.50$		1	
		$0.50 < \varphi$		None	
12	Dent on Polarizer (Minor defect)	<b>Diameter</b>		<b>Acc. Qty</b>	
		$\varphi \leq 0.20$		Ignore	
		$0.20 < \varphi \leq 0.30$		4	
		$0.30 < \varphi \leq 0.50$		1	
		$0.50 < \varphi$		None	
13	Bezel	13.1 No rust, distortion on the Bezel. 13.2 No visible fingerprints, stains or other contamination.			
14	PCB	14.1 No distortion or contamination on PCB terminals. 14.2 All components on PCB must same as documented on the BOM/component layout. 14.3 Follow IPC-A-600F.			
15	Soldering	Follow IPC-A-610C standard			
16	Electrical Defect (Major defect)	The below defects must be rejected. 16.1 Missing vertical / horizontal segment, 16.2 Abnormal Display. 16.3 No function or no display. 16.4 Current exceeds product specifications. 16.5 LCD viewing angle defect. 16.6 No Backlight. 16.7 Dark Backlight. 16.8 Touch Panel no function.			

Remark: LCD Panel Broken shall be rejected. Defect out of LCD viewing area is acceptable.

**10.7. Classification of Defects**

- 10.7.1. Visual defects (Except no / wrong label) are treated as minor defect and electrical defect is major.
- 10.7.2. Two minor defects are equal to one major in lot sampling inspection.

**10.8. Identification/marketing criteria**

Any unit with illegible / wrong /double or no marking/ label shall be rejected.

**10.9. Packaging**

- 10.9.1. There should be no damage of the outside carton box, each packaging box should have one identical label.
- 10.9.2. Modules inside package box should have compliant mark.
- 10.9.3. All direct package materials shall offer ESD protection

**Note1:** Bright dot is defined as the defective area of the dot is larger than 50% of one sub-pixel area.

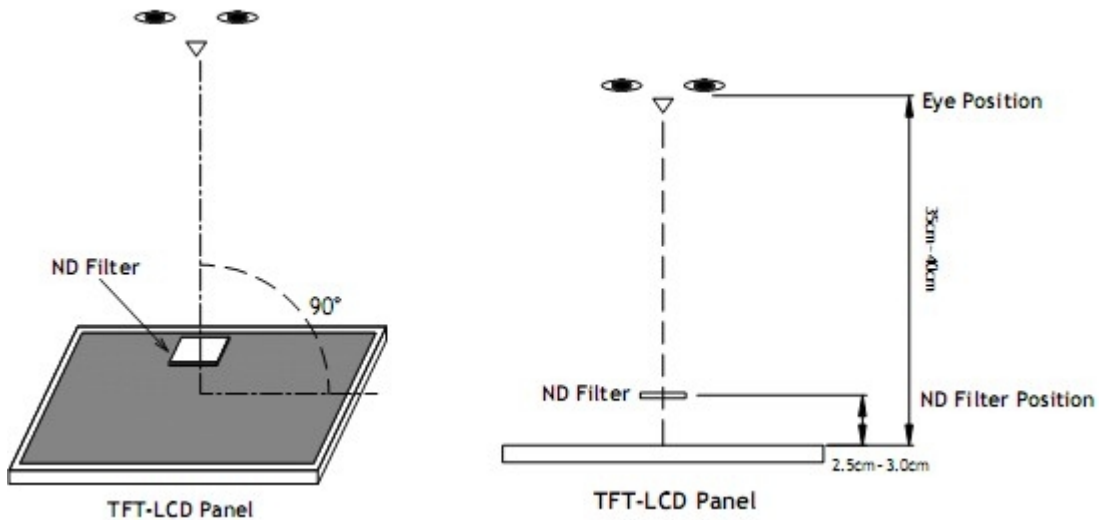

Bright dot: The bright dot size defect at black display pattern. It can be recognized by 2% transparency of filter when the distance between eyes and panel is  $350\text{mm} \pm 50\text{mm}$ .

Dark dot: Cyan, Magenta or Yellow dot size defect at white display pattern. It can be recognized by 5% transparency of filter when the distance between eyes and panel is  $350\text{mm} \pm 50\text{mm}$ .

**Note2:** Mura on display which appears darker / brighter against background brightness on parts of display area.

## 11. Reliability Specification

No	Item	Condition	Quantity	Criteria
1	High Temperature Operating	+70°C, 96Hrs	2	GB/T2423.2-2008
2	Low Temperature Operating	-20°C, 96Hrs	2	GB/T2423.1-2008
3	High Humidity Storage	+50°C, 90%RH, 96Hrs	2	GB/T2423.3-2006
4	High Temperature Storage	+80°C, 96Hrs	2	GB/T2423.2-2008
5	Low Temperature Storage	-30°C, 96Hrs	2	GB/T2423.1-2008
6	Thermal Cycling Test Storage	-20°C, 60min~+70°C, 60min, 20 cycles.	2	GB/T2423.22-2012
7	Packing Vibration	Frequency range:10Hz~50Hz Acceleration of gravity:5G X, Y, Z 30 min for each direction.	2	GB/T5170.14-2009
8	Electrical Static Discharge	Air: ±8kV 150pF/330 Ω 5 times	2	GB/T17626.2-2006
		Contact: ±4kV 150pF/330 Ω 5 times		
9	Drop Test (Packaged)	Height:80 cm,1 corner, 3 edges, 6 surfaces.	2	GB/T2423.8-1995

Note1. No deflection cosmetic and operational function allowable.

Note2. Total current Consumption should be below double of initial value

**12. Precautions and Warranty**

**12.1.Safety**

- 12.1.1. The liquid crystal in the LCD is poisonous. Do not put it in your mouth. If the liquid crystal touches your skin or clothes, wash it off immediately using soap and water.
- 12.1.2. Since the liquid crystal cells are made of glass, do not apply strong impact on them. Handle with care.

**12.2.Handling**

- 12.2.1. Reverse and use within ratings in order to keep performance and prevent damage.
- 12.2.2. Do not wipe the polarizer with dry cloth, as it might cause scratch. If the surface of the LCD needs to be cleaned, wipe it swiftly with cotton or other soft cloth soaked with petroleum IPA, do not use other chemicals.

**12.3.Storage**

- 12.3.1. Do not store the LCD module beyond the specified temperature ranges.
- 12.3.2. Strong light exposure causes degradation of polarizer and color filter.

**12.4.Metal Pin (Apply to Products with Metal Pins)**

- 12.4.1. Pins of LCD and Backlight
  - 12.4.1.1. Solder tip can touch and press on the tip of Pin LEAD during the soldering

12.4.1.2. Recommended Soldering Conditions

Solder Type: Sn96.3~94-Ag3.3~4.3-Cu0.4~1.1

Maximum Solder Temperature: 370°C

Maximum Solder Time: 3s at the maximum temperature

Recommended Soldering Temp: 350±20°C

Typical Soldering Time: ≤3s

12.4.1.3. Solder Wetting

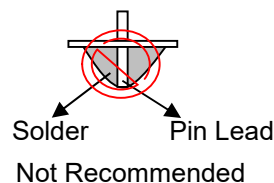
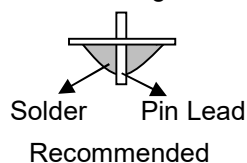

12.4.2. Pins of EL

- 12.4.2.1. Solder tip can touch and press on the tip of EL leads during soldering.
- 12.4.2.2. No Solder Paste on the soldering pad on the motherboard is recommended.

12.4.2.3. Recommended Soldering Conditions

Solder type: Nippon Alimit Leadfree SR-34, size 0.5mm

Recommended Solder Temperature: 270~290°C

Typical Soldering Time: ≤2s

Minimum solder distance from EL lamp (body):2.0mm

- 12.4.2.4. No horizontal press on the EL leads during soldering.

- 12.4.2.5. 180° bend EL leads three times is not allowed.

12.4.2.6. Solder Wetting

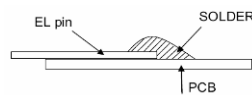

Recommended

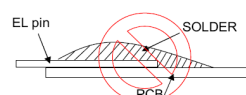

Not Recommended

12.4.2.7. The type of the solder iron:

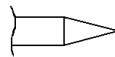

Recommended

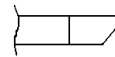

Not Recommended

12.4.2.8. Solder Pad

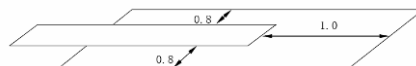

**12.5.Operation**

- 12.5.1. Do not drive LCD with DC voltage
- 12.5.2. Response time will increase below lower temperature
- 12.5.3. Display may change color with different temperature
- 12.5.4. Mechanical disturbance during operation, such as pressing on the display area, may cause the segments to appear “fractured”.
- 12.5.5. Do not connect or disconnect the LCM to or from the system when power is on.
- 12.5.6. Never use the LCM under abnormal condition of high temperature and high humidity.
- 12.5.7. Module has high frequency circuits. Sufficient suppression to the electromagnetic interface shall be done by system manufacturers. Grounding and shielding methods may be important to minimize the interference.
- 12.5.8. Do not display the fixed pattern for long time (we suggest the time not longer than one hour) because it may develop image sticking due to the TFT structure.

**12.6.Static Electricity**

- 12.6.1. CMOS LSIs are equipped in this unit, so care must be taken to avoid the electro-static charge, by ground human body, etc.
- 12.6.2. The normal static prevention measures should be observed for work clothes and benches.
- 12.6.3. The module should be kept into anti-static bags or other containers resistant to static for storage.

**12.7.Limited Warranty**

- 12.7.1. Our warranty liability is limited to repair and/or replacement. We will not be responsible for any consequential loss.
- 12.7.2. If possible, we suggest customer to use up all modules in six months. If the module storage time over twelve months, we suggest that recheck it before the module be used.
- 12.7.3. After the product shipped, any product quality issues must be feedback within three months, otherwise, we will not be responsible for the subsequent or consequential events.

13. Outline Drawing

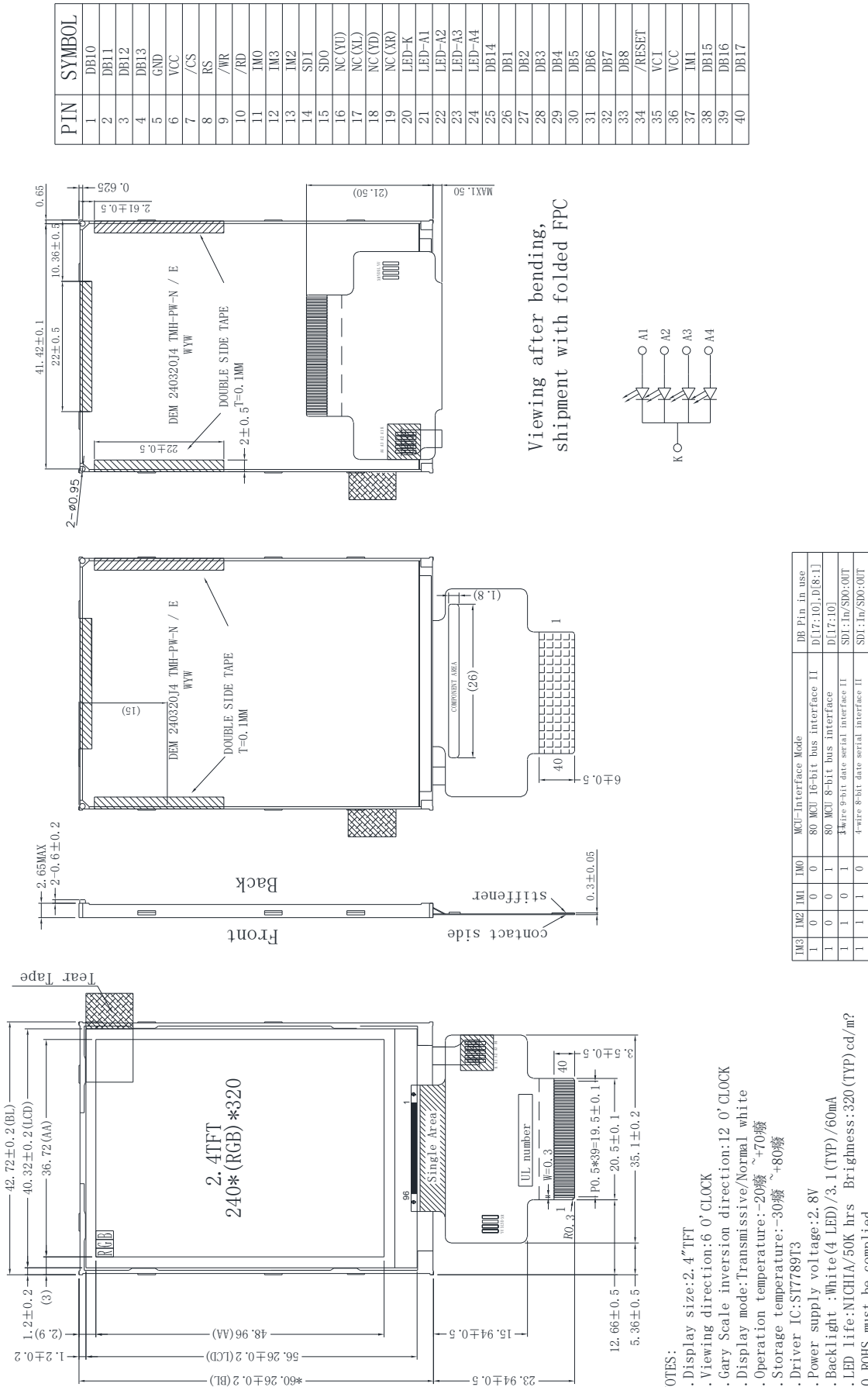

PIN	SYMBOL
1	DB10
2	DB11
3	DB12
4	DB13
5	GND
6	VCC
7	/CS
8	RS
9	/WR
10	/RD
11	IM0
12	IM3
13	IM2
14	SDI
15	SDO
16	NC(YU)
17	NC(XL)
18	NC(YD)
19	NC(XR)
20	LED-K
21	LED-A1
22	LED-A2
23	LED-A3
24	LED-A4
25	DB14
26	DB1
27	DB2
28	DB3
29	DB4
30	DB5
31	DB6
32	DB7
33	DB8
34	/RESET
35	VCI
36	VCC
37	IMI
38	DB15
39	DB16
40	DB17

IM3	IM2	IM1	IM0	MCU-Interface Mode	DB-Pin_in use
1	0	0	0	80 MCU 16-bit bus interface II	D[17:10],D[8:1]
1	0	0	1	80 MCU 8-bit bus interface I	D[17:10]
1	1	0	1	4-wire 9-bit data serial interface I	SDI:In/S90C01T
1	1	1	0	4-wire 8-bit data serial interface II	SDI:In/S90C01T

- NOTES:
1. Display size: 2.4" TFT
  2. Viewing direction: 6 O' CLOCK
  3. Gary Scale inversion direction: 12 O' CLOCK
  4. Display mode: Transmissive/Normal white
  5. Operation temperature: -20°C ~ +70°C
  6. Storage temperature: -30°C ~ +80°C
  7. Driver IC: ST7789T3
  8. Power supply voltage: 2.8V
  9. Backlight : White (4 LED) / 3.1 (TYP) / 60mA
  10. LED life: NICHIA/50K hrs Brightness: 320 (TYP) cd/m<sup>2</sup>
- \* Unspecification tolerance are ? .2mm