

Display Elektronik GmbH

# DATA SHEET

***TFT MODULE***

**DEM 320480C VMH-PW-N**

**3,5" TFT**

Product Specification

Ver.: 3

22.07.2022

**Revision History**

<b>Revision</b>	<b>Date</b>	<b>Originator</b>	<b>Detail</b>	<b>Remarks</b>
0	10.05.2022	MHI	Initial Release	
1	13.05.2022	MHI	Modify Details	
2	16.05.2022	MHI	Modify Details	
3	22.07.2022	MH	Modify Item 5.1 and Item 7.1	

**Table of Contents**

No.	Item	Page
1.	General Description.....	4
2.	Module Parameter.....	4
3.	Absolute Maximum Ratings.....	6
4.	DC Characteristics.....	6
5.	Backlight Characteristic.....	6
5.1.	Backlight Characteristics.....	6
5.2.	Backlighting circuit.....	7
6.	Touch Screen Panel Specifications.....	7
7.	Optical Characteristics.....	7
7.1.	Optical Characteristics.....	7
7.2.	Definition of Response Time.....	8
7.3.	Definition of Contrast Ratio.....	9
7.4.	Definition of Viewing Angles.....	9
7.5.	Definition of Color Appearance.....	9
7.6.	Definition of Surface Luminance, Uniformity and Transmittance.....	10
8.	Block Diagram and Power Supply.....	11
9.	Interface Pins Definition.....	12
10.	AC Characteristics.....	13
11.	Quality Assurance.....	15
11.1.	Purpose.....	15
11.2.	Standard for Quality Test.....	15
11.3.	Nonconforming Analysis & Disposition.....	15
11.4.	Agreement Items.....	15
11.5.	Standard of the Product Visual Inspection.....	15
11.6.	Inspection Specification.....	16
11.7.	Classification of Defects.....	20
11.8.	Identification/marketing criteria.....	20
11.9.	Packing.....	20
12.	Reliability Specification.....	21
13.	Precautions and Warranty.....	22
13.1.	Safety.....	22
13.2.	Handling.....	22
13.3.	Storage.....	22
13.4.	Metal Pin (Apply to Products with Metal Pins).....	22
13.5.	Operation.....	23
13.6.	Static Electricity.....	23
13.7.	Limited Warranty.....	23

## 1. General Description

The specification is a transmissive type color active matrix liquid crystal display (LCD) which uses amorphous thin film transistor (TFT) as switching devices. This product is composed of a TFT-LCD panel, driver ICs and a backlight unit.

## 2. Module Parameter

Features	Details	Unit
Display Size(Diagonal)	3.5"	-
LCD Type	IPS TFT	-
Display Mode	Transmissive /Normally black	-
Resolution	320RGB x 480	Pixels
View Direction	FULL view	Best Image
Module Outline	54.48(H) x 84.71(V) x 2.20 (T) (Note1 )	mm
Active Area	48.96 (H) x73.44(V)	mm
Pixel Pitch	0.153(H) x 0.153(V)	mm
Pixel Arrangement	RGB Vertical Stripe	-
Display Colors	262K	-
Interface	RGB + 3SPI (default)	-
Driver IC	ILI9488	-
With or Without Touch Panel	Without	-
Operating Temperature	-20~70	°C
Storage Temperature	-30~80	°C
Weight	20	g

Note 1: Exclusive hooks, posts, FFC/FPC tail etc.

2.1 Outline drawing

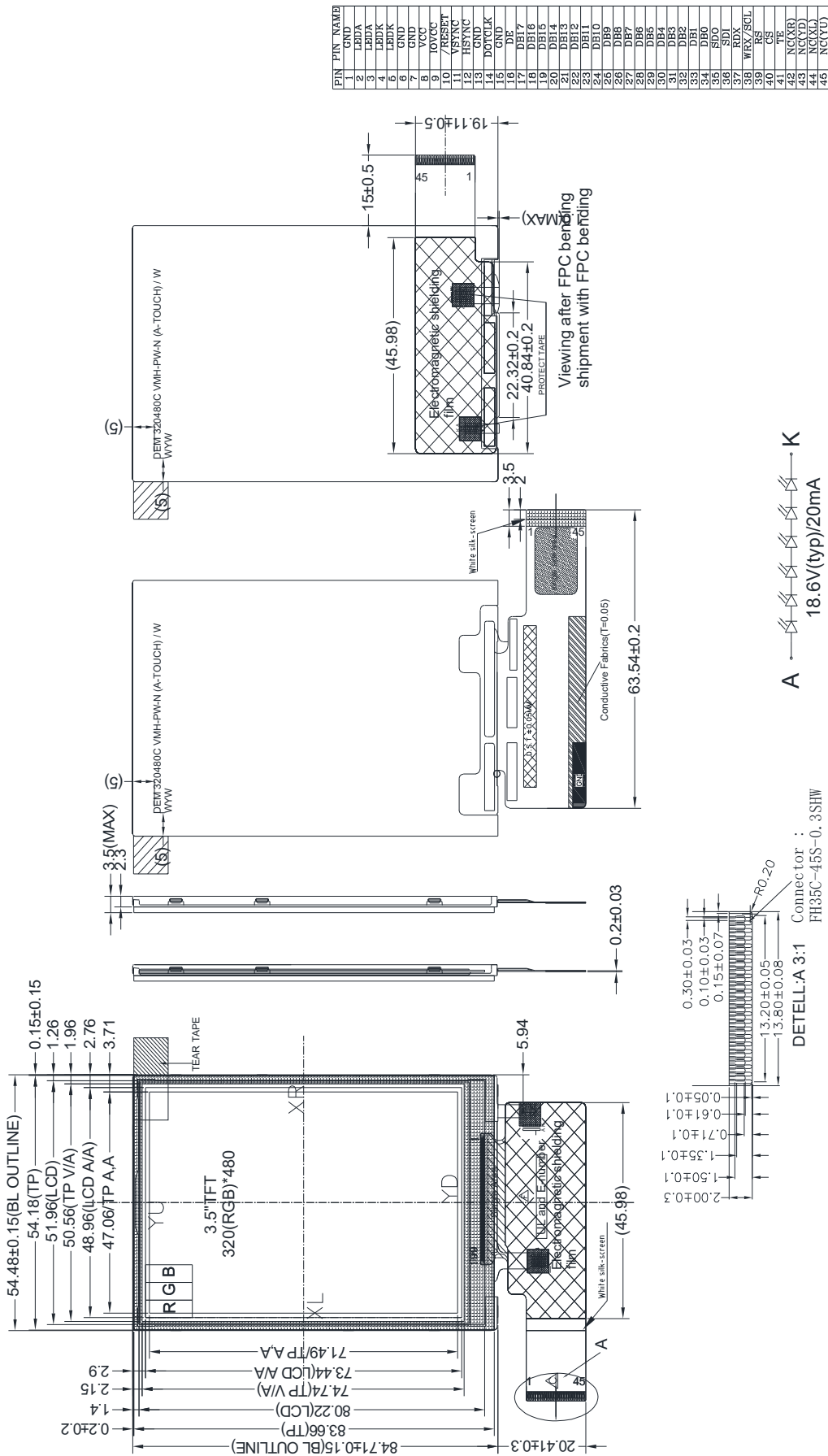

A K  
18.6V(typ)/20mA

DETELL A 3:1 Connector :  
FH35C-45S-0.3SHW

### 3. Absolute Maximum Ratings

GND =0V, Ta=25°C

Item	Symbol	Min.	Max.	Unit
Power supply voltage	VCC	-0.3	4.6	V
	IOVCC	-0.3	4.6	V
Storage temperature	T <sub>STG</sub>	-30	+80	°C
Operating temperature	T <sub>OP</sub>	-20	+70	°C

**Note 1:** If Ta below 50°C, the maximal humidity is 90%RH, if Ta over 50°C, absolute humidity should be less than 60%RH.

**Note 2:** The response time will be extremely slow when the operating temperature is around -10°C, and the back ground will become darker at high temperature operating.

### 4. DC Characteristics

Item	Symbol	Min.	Typ.	Max.	Unit
Supply Voltage	VCC	2.5	2.8	3.3	V
	IOVCC	1.65	1.8	3.3	V
Logic Low input voltage	V <sub>IL</sub>	-0.3	-	0.3*IOVCC	V
Logic High input voltage	V <sub>IH</sub>	0.7*IOVCC	-	IOVCC	V
Logic Low output voltage	V <sub>OL</sub>	0	-	0.2*IOVCC	V
Logic High output voltage	V <sub>OH</sub>	0.8*IOVCC	-	IOVCC	V
Current Consumption All white	Logic	I <sub>CC+ I<sub>IN</sub></sub>	-	(20)	mA
	Analog				

### 5. Backlight Characteristic

#### 5.1. Backlight Characteristics

Item	Symbol	Condition	Min.	Typ.	Max.	Unit
Forward Voltage	V <sub>F</sub>	Ta=25 °C, I <sub>F</sub> =20mA/LED	16.8	18.6	20.4	V
Forward Current	I <sub>F</sub>	Ta=25 °C, V <sub>F</sub> =3.2V/LED	-	20	-	mA
Power Dissipation	P <sub>D</sub>	-	-	372	-	mW
Uniformity	Avg	-	-	80	-	%
LED Lifetime (25°C)	-	-	-	30,000	-	Hrs
Drive Method	Constant current					
LED Configuration	6 White LEDs in serial					

Note1: LED life time defined as follows: The final brightness is at 50% of original brightness.

The environmental conducted under ambient air flow, at Ta=25°C±2°C, 60%RH±5%, I<sub>F</sub>=20mA/LED.

5.2. Backlighting Circuit



6. Touch Screen Panel Specifications

Without TP

7. Optical Characteristics

7.1. Optical Characteristics

Ta=25°C, VCC=2.8V

	Item	Symbol	Condition	Specification			Unit	
				Min.	Typ.	Max.		
Backlight On (Transmissive Mode)	Luminance on TFT( $I_f=20mA/LED$ )	Lv	Normally viewing angle $\theta_x = \phi_y = 0^\circ$	280	360	-	cd/m <sup>2</sup>	
	Contrast ratio(See 7.3)	CR			700	-		
	Response time (See 7.2)	T <sub>R</sub>			-	30	-	ms
		T <sub>F</sub>						
	Chromacity Transmissive (See 7.5)	White	X <sub>w</sub>	0.29	0.34	0.39	-	
			Y <sub>w</sub>	0.34	0.39	0.44	-	
	Viewing Angle (See 7.4)	Horizontal	$\theta_{x+}$	Center CR≥10	65	80	-	Deg.
			$\theta_{x-}$		65	80	-	
		Vertical	$\phi_{y+}$		65	80	-	
			$\phi_{y-}$		65	80	-	
NTSC Ratio(Gamut)	-	-	-	69	-	%		

7.2. Definition of Response Time

7.2.1. Normally Black Type (Negative)

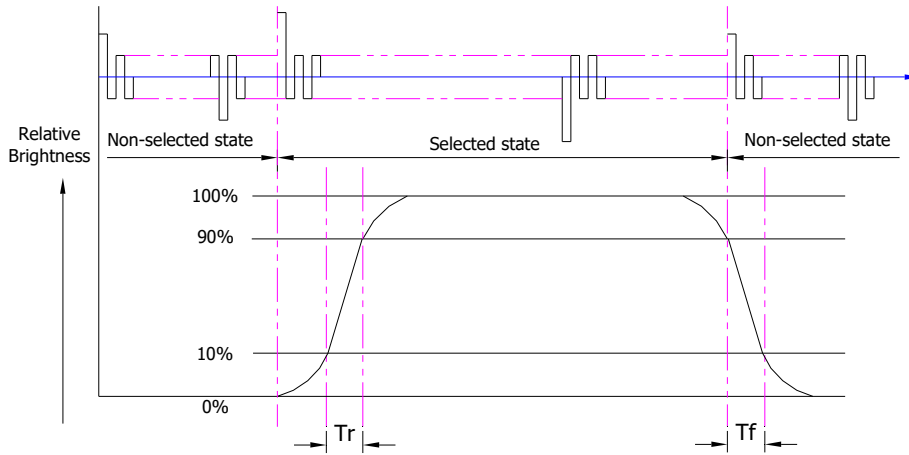

Tr is the time it takes to change from non-selected stage with relative luminance 10% to selected state with relative luminance 90%;

Tf is the time it takes to change from selected state with relative luminance 90% to non-selected state with relative luminance 10%.

Note: Measuring machine: LCD-5100

7.2.2. Normally White Type (Positive)

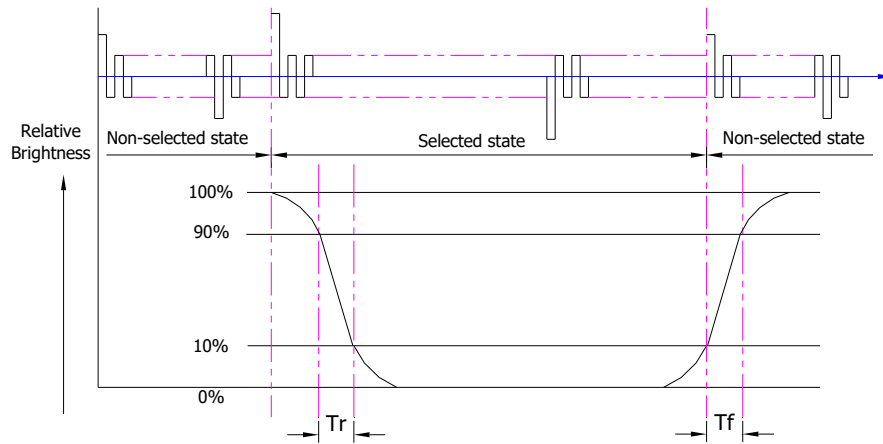

Tr is the time it takes to change from non-selected stage with relative luminance 90% to selected state with relative luminance 10%;

Tf is the time it takes to change from selected state with relative luminance 10% to non-selected state with relative luminance 90%;

Note: Measuring machine: LCD-5100 or EQUI



**7.3. Definition of Contrast Ratio**

Contrast is measured perpendicular to display surface in reflective and transmissive mode. The measurement condition is:

Measuring Equipment	Eldim or Equivalent
Measuring Point Diameter	3mm//1mm
Measuring Point Location	Active Area centre point
Test pattern	A: All Pixels white
	B: All Pixel black
Contrast setting	Maximum

Definitions: CR (Contrast) = Luminance of White Pixel / Luminance of Black Pixel

**7.4. Definition of Viewing Angles**

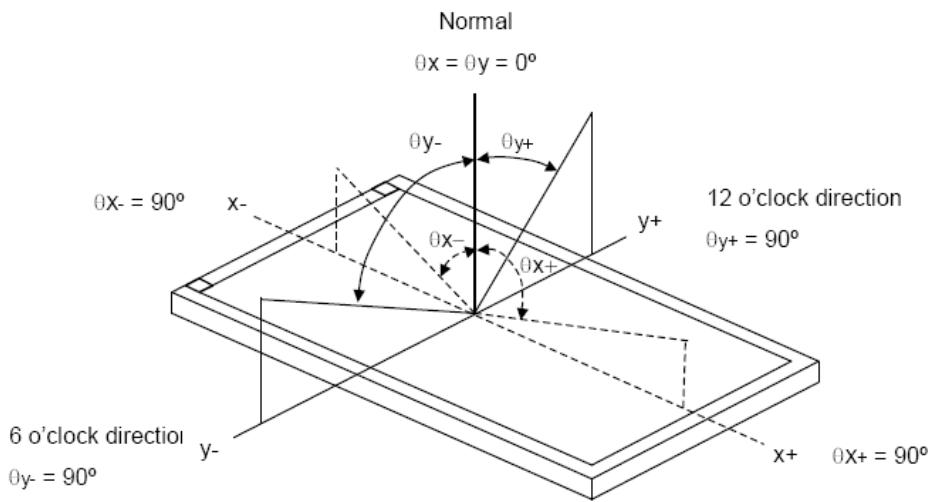

Measuring machine: LCD-5100 or EQUI

**7.5. Definition of Color Appearance**

R,G,B and W are defined by (x, y) on the IE chromaticity diagram

NTSC=area of RGB triangle/area of NTSC triangleX100%

Measuring picture: Red, Green, Blue and White (Measuring machine: BM-7)

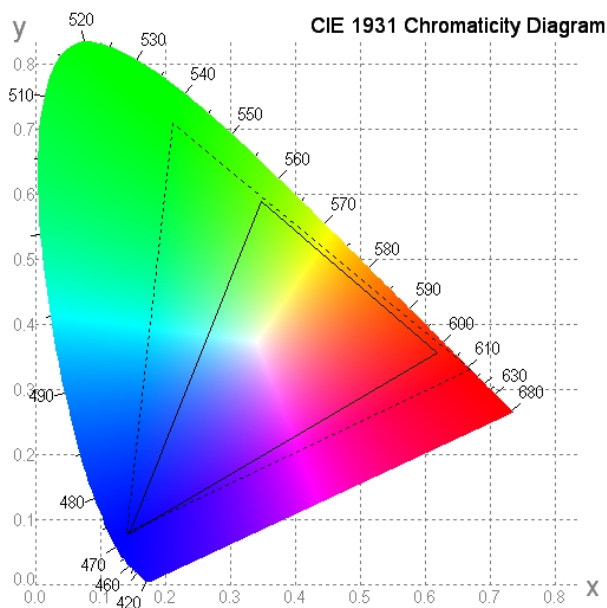

**7.6. Definition of Surface Luminance, Uniformity and Transmittance**

Using the transmissive mode measurement approach, measure the white screen luminance of the display panel and backlight.

7.6.1. Surface Luminance:  $L_V = \text{average } (L_{P1}:L_{P9})$

7.6.2. Uniformity =  $\text{Minimal } (L_{P1}:L_{P9}) / \text{Maximal } (L_{P1}:L_{P9}) * 100\%$

7.6.3. Transmittance =  $L_V \text{ on LCD} / L_V \text{ on Backlight} * 100\%$

Note: Measuring machine: BM-7

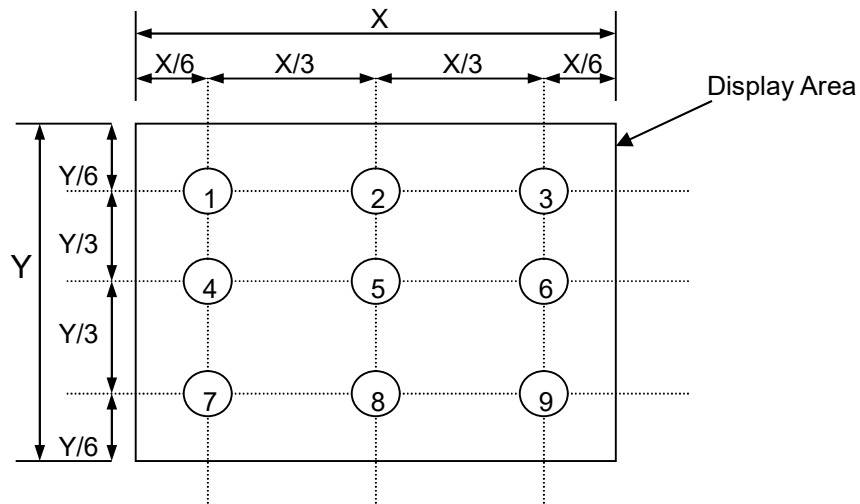

### 8. Block Diagram and Power Supply

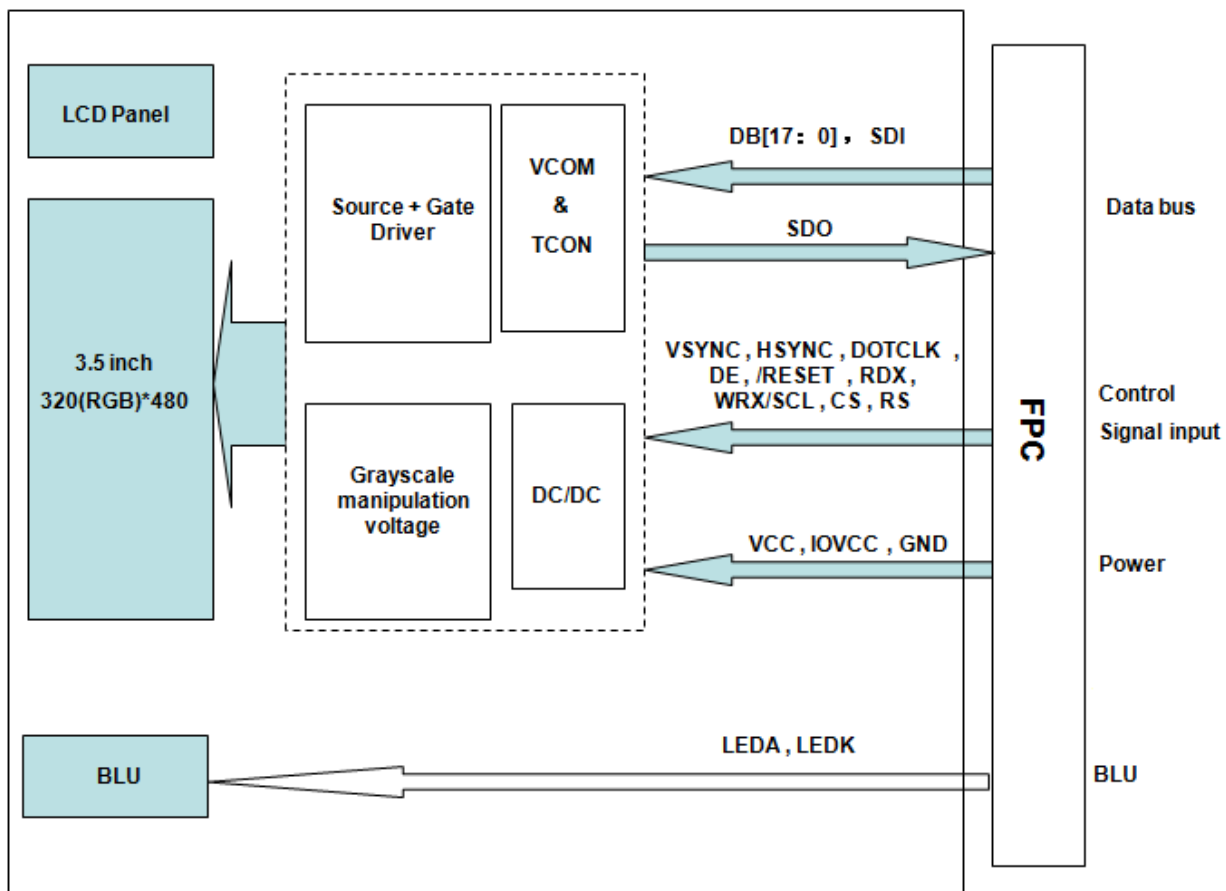

## 9. Interface Pins Definition

Connector type : FH35C-45S-0.3SHW

No.	Symbol	Function
1	GND	Power Ground
2	LEDA	Anode for back light driver voltage
3	LEDA	Anode for back light driver voltage
4	LEDK	Cathode for back light driver voltage
5	LEDK	Cathode for back light driver voltage
6	GND	Power Ground
7	GND	Power Ground
8	VCC	Power supply
9	IOVCC	Power supply
10	/RESET	Reset input pin. Signal is active low.
11	VSYNC	Vertical Sync Signal
12	HSYNC	Horizontal Sync Signal
13	GND	Power Ground
14	DOTCLK	Pixel clock signal
15	GND	Power Ground
16	DE	Data Enable signal.
17	DB17	Data bus
18	DB16	Data bus
19	DB15	Data bus
20	DB14	Data bus
21	DB13	Data bus
22	DB12	Data bus
23	DB11	Data bus
24	DB10	Data bus
25	DB9	Data bus
26	DB8	Data bus
27	DB7	Data bus
28	DB6	Data bus
29	DB5	Data bus
30	DB4	Data bus
31	DB3	Data bus
32	DB2	Data bus
33	DB1	Data bus
34	DB0	Data bus
35	SDO	Serial data output
36	SDI	Serial data input pin.
37	RDX	LCD driver read enable
38	WRX/SCL	DBI Type B:WRX pin, serves as a write signal DBI Type C:SCL pin as Serial Clock when operates in the serial interface
39	RS	Command/Display data selection signal

40	CS	Chip select signal
41	TE	Tearing effect output pin
42	NC/XR	NC
43	NC/YD	NC
44	NC/XL	NC
45	NC/YU	NC

### 10. AC Characteristics

#### 1) 3-SPI Serial Data Transfer Interface Characteristics

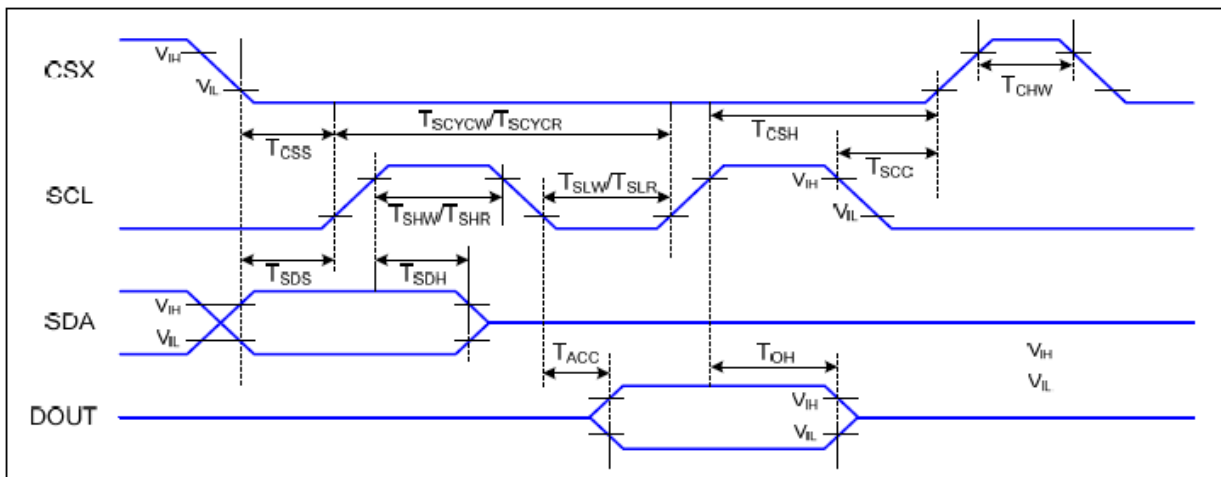

Signal	Symbol	Parameter	Min	Max	Unit	Description
CSX	$T_{CSS}$	Chip select setup time (write)	15		ns	
	$T_{CSH}$	Chip select hold time (write)	15		ns	
	$T_{CSS}$	Chip select setup time (read)	60		ns	
	$T_{SCC}$	Chip select hold time (read)	65		ns	
	$T_{CHW}$	Chip select "H" pulse width	40		ns	
SCL	$T_{SCYCW}$	Serial clock cycle (Write)	66		ns	
	$T_{SHW}$	SCL "H" pulse width (Write)	15		ns	
	$T_{SLW}$	SCL "L" pulse width (Write)	15		ns	
	$T_{SCYCR}$	Serial clock cycle (Read)	150		ns	
	$T_{SHR}$	SCL "H" pulse width (Read)	60		ns	
	$T_{SLR}$	SCL "L" pulse width (Read)	60		ns	
SDA (DIN)	$T_{SDS}$	Data setup time	10		ns	
	$T_{SDH}$	Data hold time	10		ns	
DOUT	$T_{ACC}$	Access time	10	50	ns	For maximum CL=30pF
	$T_{OH}$	Output disable time	15	50	ns	For minimum CL=8pF

2) RGB Interface Characteristics

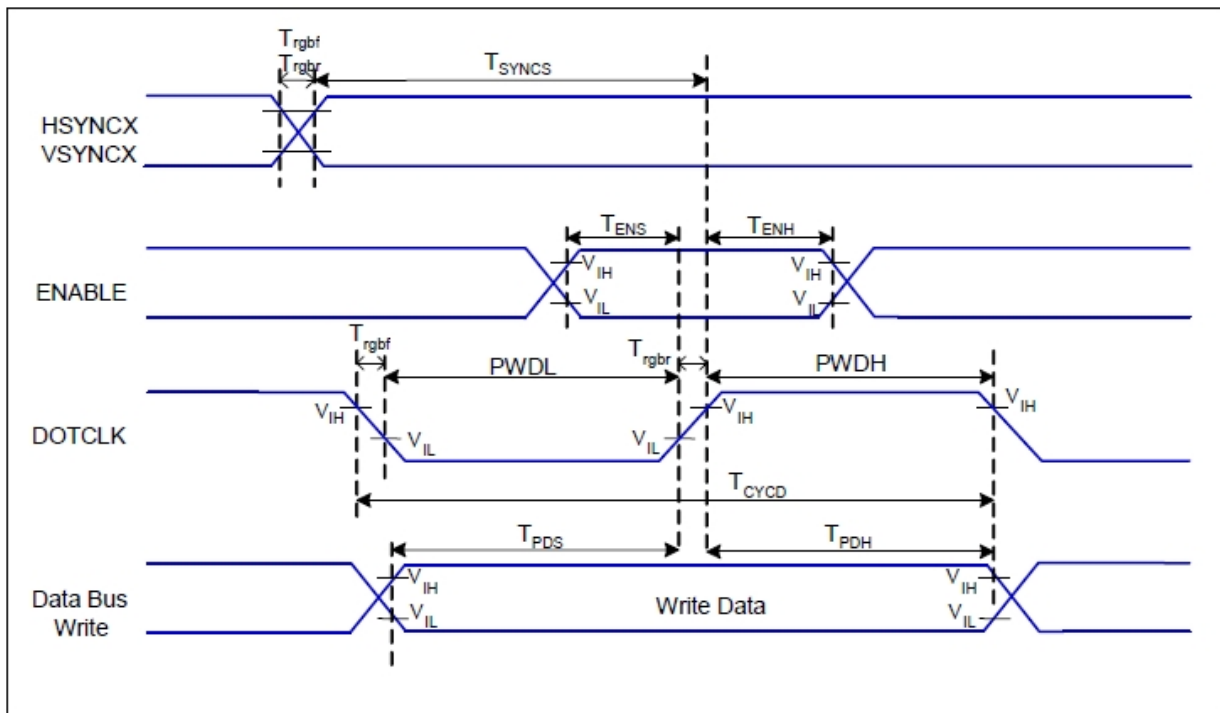

Signal	Symbol	Parameter	MIN	MAX	Unit	Description
HSYNC, VSYNC	$T_{SYNCS}$	VSYNC, HSYNC Setup Time	15	-	ns	
ENABLE	$T_{ENS}$	Enable Setup Time	15	-	ns	
	$T_{ENH}$	Enable Hold Time	15	-	ns	
DOTCLK	PWDH	DOTCLK High-level Pulse Width	30	-	ns	
	PWDL	DOTCLK Low-level Pulse Width	30	-	ns	
	$T_{CYCD}$	DOTCLK Cycle Time	66	-	ns	
	Trghr, Trghf	DOTCLK Rise/Fall time	-	15	ns	
DB	$T_{PDS}$	PD Data Setup Time	15	-	ns	
	$T_{PDH}$	PD Data Hold Time	15	-	ns	

## **11. Quality Assurance**

### **11.1.Purpose**

This standard for Quality Assurance assures the quality of LCD module products supplied to customer.

### **11.2.Standard for Quality Test**

#### 11.2.1. Sampling Plan:

GB2828.1-2012

Single sampling, general inspection level II

#### 11.2.2. Sampling Criteria:

Visual inspection: AQL 1.5.

Electrical functional: AQL 0.65.

#### 11.2.3. Reliability Test:

Detailed requirement refer to Reliability Test Specification.

### **11.3.Nonconforming Analysis & Disposition**

#### 11.3.1. Nonconforming analysis:

11.3.1.1. Customer should provide overall information of non-conforming sample for their complaints.

11.3.1.2. After receipt of detailed information from customer, the analysis of nonconforming parts usually should be finished in one week.

11.3.1.3. If cannot finish the analysis on time, customer will be notified with the progress status.

#### 11.3.2. Disposition of nonconforming:

11.3.2.1. Non-conforming product over PPM level will be replaced.

11.3.2.2. The cause of non-conformance will be analyzed. Corrective action will be discussed and implemented.

### **11.4.Agreement Items**

Shall negotiate with customer if the following situation occurs:

11.4.1. There is any discrepancy in standard of quality assurance.

11.4.2. Additional requirement to be added in product specification.

11.4.3. Any other special problem.

### **11.5.Standard of the Product Visual Inspection**

#### 11.5.1. Appearance inspection:

11.5.1.1. The inspection must be under illumination about 1000 – 1500 lx, and the distance of view must be at 30cm ± 2cm.

11.5.1.2. The viewing angle should be 45° from the vertical line without reflection light or follows customer's viewing angle specifications.

11.5.1.3. Definition of area: A Zone: Active Area, B Zone: Viewing Area,

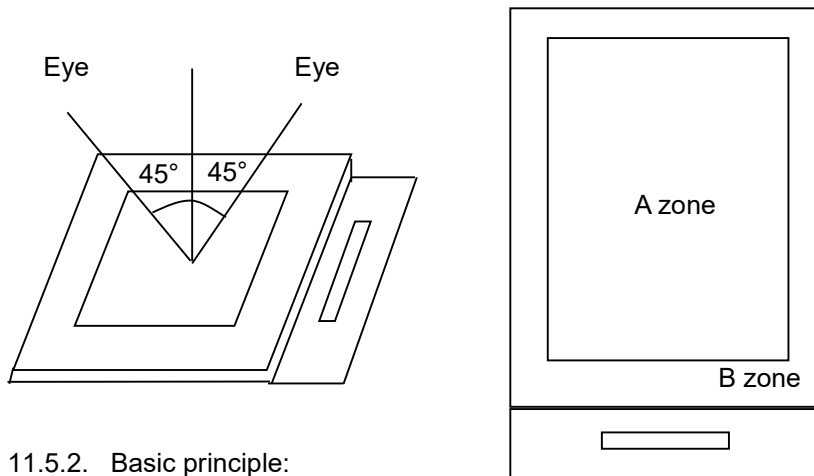

11.5.2. Basic principle:

11.5.2.1. A set of sample to indicate the limit of acceptable quality level must be discussed by both us and customer when there is any dispute happened.

11.5.2.2. New item must be added on time when it is necessary.

11.6. Inspection Specification

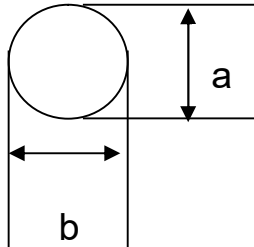
No.	Item	Criteria (Unit: mm)																	
01	Black / White spot Foreign material (Round type) Pinholes Stain Particles inside cell. (Minor defect)	 $\phi = (a + b) / 2$ <table border="1" data-bbox="909 974 1412 1310"> <thead> <tr> <th>Size \ Area</th> <th>Acc. Qty</th> </tr> </thead> <tbody> <tr> <td><math>\phi \leq 0.10</math></td> <td>Ignore</td> </tr> <tr> <td><math>0.10 &lt; \phi \leq 0.15</math></td> <td>2</td> </tr> <tr> <td><math>0.15 &lt; \phi \leq 0.25</math></td> <td>1</td> </tr> <tr> <td><math>0.25 &lt; \phi</math></td> <td>0</td> </tr> <tr> <td>Total</td> <td>2 no include <math>\phi \leq 0.10</math></td> </tr> </tbody> </table> Distance between 2 defects should more than 3mm apart.	Size \ Area	Acc. Qty	$\phi \leq 0.10$	Ignore	$0.10 < \phi \leq 0.15$	2	$0.15 < \phi \leq 0.25$	1	$0.25 < \phi$	0	Total	2 no include $\phi \leq 0.10$					
Size \ Area	Acc. Qty																		
$\phi \leq 0.10$	Ignore																		
$0.10 < \phi \leq 0.15$	2																		
$0.15 < \phi \leq 0.25$	1																		
$0.25 < \phi$	0																		
Total	2 no include $\phi \leq 0.10$																		
02	Electrical Defect (Minor defect)	<table border="1" data-bbox="550 1444 1372 1668"> <thead> <tr> <th></th> <th>Display Area</th> <th>Total</th> <th rowspan="3">Note1</th> </tr> </thead> <tbody> <tr> <td>Bright dot</td> <td>0</td> <td>0</td> </tr> <tr> <td>Dark dot</td> <td><math>N \leq 2</math></td> <td><math>N \leq 2</math></td> </tr> <tr> <td>Total dot</td> <td><math>N \leq 2</math></td> <td><math>N \leq 2</math></td> <td rowspan="2">Note 2</td> </tr> <tr> <td>Mura</td> <td colspan="2">Not visible through 5% ND filters.</td> </tr> </tbody> </table> Remark: 1. Bright dot caused by scratch and foreign object accords to item 1.		Display Area	Total	Note1	Bright dot	0	0	Dark dot	$N \leq 2$	$N \leq 2$	Total dot	$N \leq 2$	$N \leq 2$	Note 2	Mura	Not visible through 5% ND filters.	
	Display Area	Total	Note1																
Bright dot	0	0																	
Dark dot	$N \leq 2$	$N \leq 2$																	
Total dot	$N \leq 2$	$N \leq 2$	Note 2																
Mura	Not visible through 5% ND filters.																		

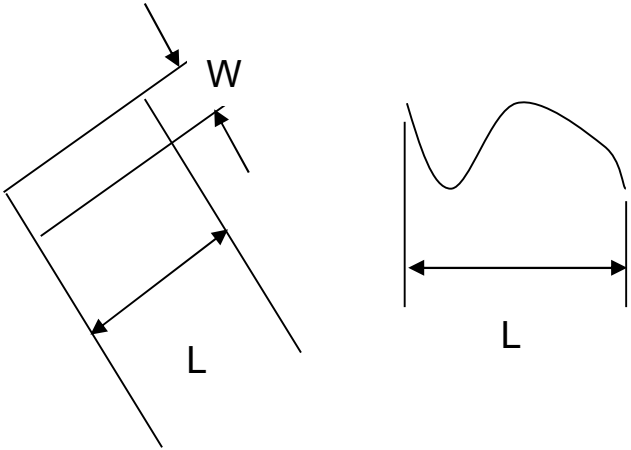
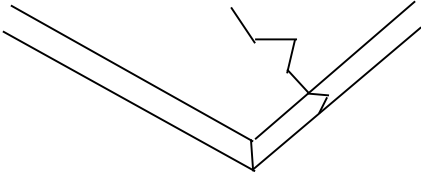
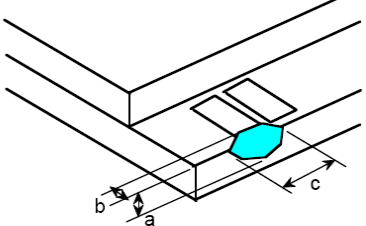

<p>03</p>	<p>Black and White line Scratch Foreign material (Line type) (Minor defect)</p>	 <table border="1" data-bbox="614 721 1241 1030"> <thead> <tr> <th>Length</th> <th>Width</th> <th>Acc. Qty</th> </tr> </thead> <tbody> <tr> <td>/</td> <td><math>W \leq 0.03</math></td> <td>Ignore</td> </tr> <tr> <td><math>L \leq 2.5</math></td> <td><math>0.03 &lt; W \leq 0.05</math></td> <td>3</td> </tr> <tr> <td><math>L \leq 2.5</math></td> <td><math>0.05 &lt; W \leq 0.10</math></td> <td>2</td> </tr> <tr> <td>/</td> <td><math>0.1 &lt; W</math></td> <td>0</td> </tr> <tr> <td colspan="2">Total</td> <td>3</td> </tr> </tbody> </table> <p>Distance between 2 defects should more than 3mm apart. Scratches not viewable through the back of the display are acceptable.</p>	Length	Width	Acc. Qty	/	$W \leq 0.03$	Ignore	$L \leq 2.5$	$0.03 < W \leq 0.05$	3	$L \leq 2.5$	$0.05 < W \leq 0.10$	2	/	$0.1 < W$	0	Total		3
Length	Width	Acc. Qty																		
/	$W \leq 0.03$	Ignore																		
$L \leq 2.5$	$0.03 < W \leq 0.05$	3																		
$L \leq 2.5$	$0.05 < W \leq 0.10$	2																		
/	$0.1 < W$	0																		
Total		3																		
<p>04</p>	<p>Glass Crack (Minor defect)</p>	 <p>Crack is potential to enlarge, any type is not allowed.</p>																		
<p>05</p>	<p>Glass Chipping Pad Area: (Minor defect)</p> 	<table border="1" data-bbox="869 1680 1340 1848"> <thead> <tr> <th>Length and Width</th> <th>Acc. Qty</th> </tr> </thead> <tbody> <tr> <td><math>c &gt; 3.0, b &lt; 1.0</math></td> <td>1</td> </tr> <tr> <td><math>c &lt; 3.0, b &lt; 1.0</math></td> <td>3</td> </tr> <tr> <td colspan="2"><math>a &lt; \text{Glass Thickness}</math></td> </tr> </tbody> </table>	Length and Width	Acc. Qty	$c > 3.0, b < 1.0$	1	$c < 3.0, b < 1.0$	3	$a < \text{Glass Thickness}$											
Length and Width	Acc. Qty																			
$c > 3.0, b < 1.0$	1																			
$c < 3.0, b < 1.0$	3																			
$a < \text{Glass Thickness}$																				

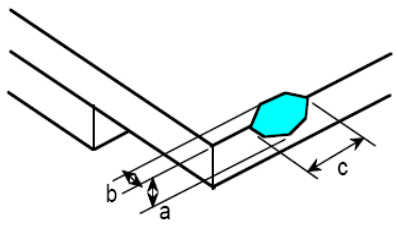
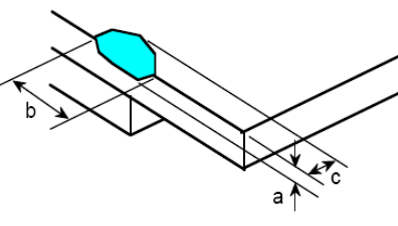
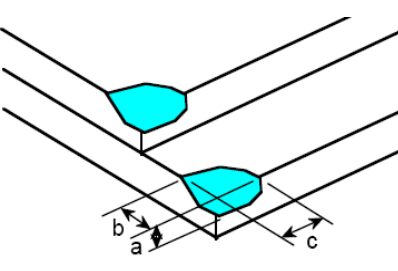
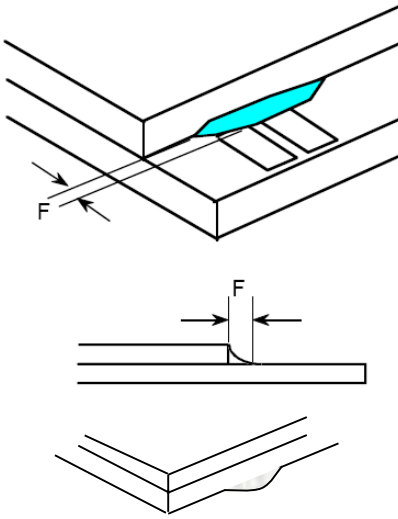
<p>06</p>	<p>Glass Chipping Rear of Pad Area: (Minor defect)</p> 	<table border="1"> <thead> <tr> <th>Length and Width</th> <th>Acc. Qty</th> </tr> </thead> <tbody> <tr> <td><math>c &gt; 3.0, b &lt; 1.0</math></td> <td>1</td> </tr> <tr> <td><math>c &lt; 3.0, b &lt; 1.0</math></td> <td>2</td> </tr> <tr> <td><math>c &lt; 3.0, b &lt; 0.5</math></td> <td>4</td> </tr> <tr> <td colspan="2">a &lt; Glass Thickness</td> </tr> </tbody> </table>	Length and Width	Acc. Qty	$c > 3.0, b < 1.0$	1	$c < 3.0, b < 1.0$	2	$c < 3.0, b < 0.5$	4	a < Glass Thickness	
Length and Width	Acc. Qty											
$c > 3.0, b < 1.0$	1											
$c < 3.0, b < 1.0$	2											
$c < 3.0, b < 0.5$	4											
a < Glass Thickness												
<p>07</p>	<p>Glass Chipping Except Pad Area: (Minor defect)</p> 	<table border="1"> <thead> <tr> <th>Length and Width</th> <th>Acc. Qty</th> </tr> </thead> <tbody> <tr> <td><math>c &gt; 3.0, b &lt; 1.0</math></td> <td>1</td> </tr> <tr> <td><math>c &lt; 3.0, b &lt; 1.0</math></td> <td>2</td> </tr> <tr> <td><math>c &lt; 3.0, b &lt; 0.5</math></td> <td>4</td> </tr> <tr> <td colspan="2">a &lt; Glass Thickness</td> </tr> </tbody> </table>	Length and Width	Acc. Qty	$c > 3.0, b < 1.0$	1	$c < 3.0, b < 1.0$	2	$c < 3.0, b < 0.5$	4	a < Glass Thickness	
Length and Width	Acc. Qty											
$c > 3.0, b < 1.0$	1											
$c < 3.0, b < 1.0$	2											
$c < 3.0, b < 0.5$	4											
a < Glass Thickness												
<p>08</p>	<p>Glass Corner Chipping: (Minor defect)</p> 	<table border="1"> <thead> <tr> <th>Length and Width</th> <th>Acc. Qty</th> </tr> </thead> <tbody> <tr> <td><math>c &lt; 3.0, b &lt; 3.0</math></td> <td>Ignore</td> </tr> <tr> <td colspan="2">a &lt; Glass Thickness</td> </tr> </tbody> </table>	Length and Width	Acc. Qty	$c < 3.0, b < 3.0$	Ignore	a < Glass Thickness					
Length and Width	Acc. Qty											
$c < 3.0, b < 3.0$	Ignore											
a < Glass Thickness												
<p>09</p>	<p>Glass Burr: (Minor defect)</p> 	<table border="1"> <thead> <tr> <th>Length</th> <th>Acc. Qty</th> </tr> </thead> <tbody> <tr> <td><math>F &lt; 1.0</math></td> <td>Ignore</td> </tr> </tbody> </table> <p>Glass burr don't affect assemble and module dimension.</p>	Length	Acc. Qty	$F < 1.0$	Ignore						
Length	Acc. Qty											
$F < 1.0$	Ignore											

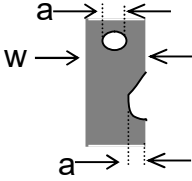
10	<p>FPC Defect: (Minor defect)</p> 	<p>10.1 Dent, pinhole width <math>a &lt; w/3</math>. (<math>w</math>: circuitry width.) 10.2 Open circuit is unacceptable. 10.3 No oxidation, contamination and distortion.</p>										
11	<p>Bubble on Polarizer (Minor defect)</p>	<table border="1"> <thead> <tr> <th>Diameter</th> <th>Acc. Qty</th> </tr> </thead> <tbody> <tr> <td><math>\varphi \leq 0.20</math></td> <td>Ignore</td> </tr> <tr> <td><math>0.20 &lt; \varphi \leq 0.30</math></td> <td>4</td> </tr> <tr> <td><math>0.30 &lt; \varphi \leq 0.50</math></td> <td>1</td> </tr> <tr> <td><math>0.50 &lt; \varphi</math></td> <td>None</td> </tr> </tbody> </table>	Diameter	Acc. Qty	$\varphi \leq 0.20$	Ignore	$0.20 < \varphi \leq 0.30$	4	$0.30 < \varphi \leq 0.50$	1	$0.50 < \varphi$	None
Diameter	Acc. Qty											
$\varphi \leq 0.20$	Ignore											
$0.20 < \varphi \leq 0.30$	4											
$0.30 < \varphi \leq 0.50$	1											
$0.50 < \varphi$	None											
12	<p>Dent on Polarizer (Minor defect)</p>	<table border="1"> <thead> <tr> <th>Diameter</th> <th>Acc. Qty</th> </tr> </thead> <tbody> <tr> <td><math>\varphi \leq 0.20</math></td> <td>Ignore</td> </tr> <tr> <td><math>0.20 &lt; \varphi \leq 0.30</math></td> <td>4</td> </tr> <tr> <td><math>0.30 &lt; \varphi \leq 0.50</math></td> <td>1</td> </tr> <tr> <td><math>0.50 &lt; \varphi</math></td> <td>None</td> </tr> </tbody> </table>	Diameter	Acc. Qty	$\varphi \leq 0.20$	Ignore	$0.20 < \varphi \leq 0.30$	4	$0.30 < \varphi \leq 0.50$	1	$0.50 < \varphi$	None
Diameter	Acc. Qty											
$\varphi \leq 0.20$	Ignore											
$0.20 < \varphi \leq 0.30$	4											
$0.30 < \varphi \leq 0.50$	1											
$0.50 < \varphi$	None											
13	<p>Bezel</p>	<p>13.1 No rust, distortion on the Bezel. 13.2 No visible fingerprints, stains or other contamination.</p>										
14	<p>Touch Panel</p>	<p>D: Diameter W: width L: length 14.1 Spot: <math>D &lt; 0.25</math> is acceptable <math>0.25 \leq D \leq 0.4</math> 2dots are acceptable and the distance between defects should more than 10 mm. <math>D &gt; 0.4</math> is unacceptable 14.2 Dent: <math>D &gt; 0.40</math> is unacceptable 14.3 Scratch: <math>W \leq 0.03, L \leq 10</math> is acceptable, <math>0.03 &lt; W \leq 0.10, L \leq 10</math> is acceptable Distance between 2 defects should more than 10 mm. <math>W &gt; 0.10</math> is unacceptable.</p>										
15	<p>PCB</p>	<p>15.1 No distortion or contamination on PCB terminals. 15.2 All components on PCB must same as documented on the BOM/component layout. 15.3 Follow IPC-A-600F.</p>										
16	<p>Soldering</p>	<p>Follow IPC-A-610C standard</p>										
17	<p>Electrical Defect (Major defect)</p>	<p>The below defects must be rejected. 17.1 Missing vertical / horizontal segment,</p>										

		17.2 Abnormal Display. 17.3 No function or no display. 17.4 Current exceeds product specifications. 17.5 LCD viewing angle defect. 17.6 No Backlight. 17.7 Dark Backlight. 17.8 Touch Panel no function.
--	--	--

Remark: LCD Panel Broken shall be rejected. Defect out of LCD viewing area is acceptable.

**11.7. Classification of Defects**

- 11.7.1. Visual defects (Except no / wrong label) are treated as minor defect and electrical defect is major.
- 11.7.2. Two minor defects are equal to one major in lot sampling inspection.

**11.8. Identification/markings criteria**

Any unit with illegible / wrong /double or no marking/ label shall be rejected.

**11.9. Packing**

- 11.9.1. There should be no damage of the outside carton box, each packaging box should have one identical label.
- 11.9.2. Modules inside package box should have compliant mark.
- 11.9.3. All direct package materials shall offer ESD protection.

**Note1:** Bright dot is defined as the defective area of the dot is larger than 50% of one sub-pixel area.

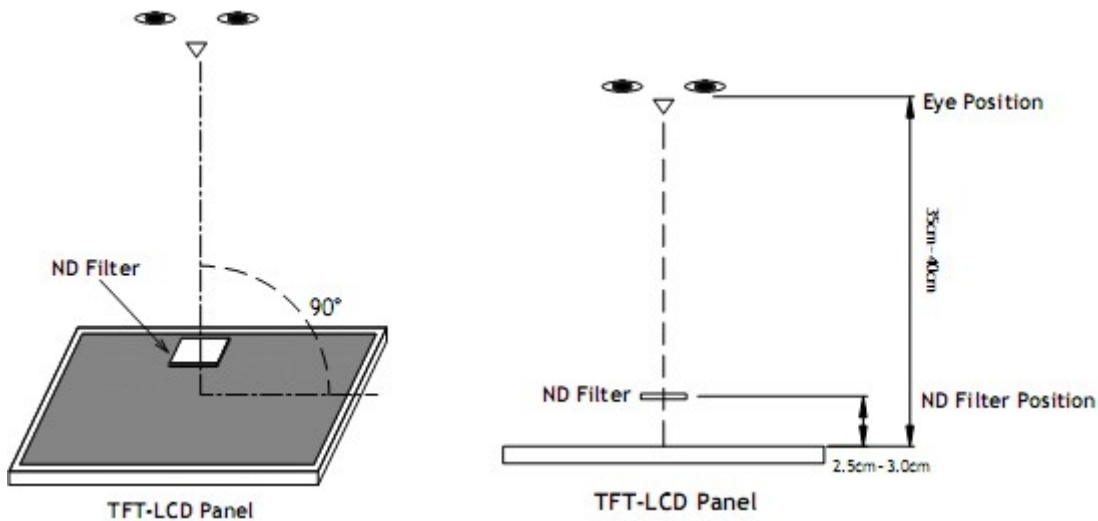

**Bright dot:** The bright dot size defect at black display pattern. It can be recognized by 2% transparency of filter when the distance between eyes and panel is 350mm±50mm.

**Dark dot:** Cyan, Magenta or Yellow dot size defect at white display pattern. It can be recognized by 5% transparency of filter when the distance between eyes and panel is 350mm±50mm.

**Note2:** Mura on display which appears darker / brighter against background brightness on parts of display area.

## 12. Reliability Specification

No	Item	Condition	Quantity	Criteria
1	High Temperature Operating	70°C, 96Hrs	2	GB/T2423.2-2008
2	Low Temperature Operating	-20°C, 96Hrs	2	GB/T2423.1-2008
3	High Humidity	50°C, 90%RH, 96Hrs	2	GB/T2423.3-2016
4	High Temperature Storage	80°C, 96Hrs	2	GB/T2423.2-2008
5	Low Temperature Storage	-30°C, 96Hrs	2	GB/T2423.1-2008
6	Thermal Cycling Test	-20°C, 60min~70°C, 60min, 20 cycles.	2	GB/T2423.22-2012
7	Packing vibration	Frequency range:10Hz~50Hz Acceleration of gravity:5G X, Y, Z 30 min for each direction.	2	GB/T5170.14-2009
8	Electrical Static Discharge	Air: $\pm 4\text{KV } 150\text{pF}/330\ \Omega$ 5 times Contact: $\pm 2\text{KV } 150\text{pF}/330\ \Omega$ 5 times	2	GB/T17626.2-2018
9	Drop Test (Packaged)	Height:80 cm,1 corner, 3 edges, 6 surfaces.	2	GB/T2423.8-1995

Note1. No deflection cosmetic and operational function allowable.

Note2. Total current Consumption should be below double of initial value

## 13. Precautions and Warranty

### 13.1. Safety

- 13.1.1. The liquid crystal in the LCD is poisonous. Do not put it in your mouth. If the liquid crystal touches your skin or clothes, wash it off immediately using soap and water.
- 13.1.2. Since the liquid crystal cells are made of glass, do not apply strong impact on them. Handle with care.

### 13.2. Handling

- 13.2.1. Reverse and use within ratings in order to keep performance and prevent damage.
- 13.2.2. Do not wipe the polarizer with dry cloth, as it might cause scratch. If the surface of the LCD needs to be cleaned, wipe it swiftly with cotton or other soft cloth soaked with petroleum IPA, do not use other chemicals.

### 13.3. Storage

- 13.3.1. Do not store the LCD module beyond the specified temperature ranges.
- 13.3.2. Strong light exposure causes degradation of polarizer and color filter.

### 13.4. Metal Pin (Apply to Products with Metal Pins)

#### 13.4.1. Pins of LCD and Backlight

13.4.1.1. Solder tip can touch and press on the tip of Pin LEAD during the soldering

13.4.1.2. Recommended Soldering Conditions

Solder Type: Sn96.3~94-Ag3.3~4.3-Cu0.4~1.1

Maximum Solder Temperature: 370°C

Maximum Solder Time: 3s at the maximum temperature

Recommended Soldering Temp: 350±20°C

Typical Soldering Time: ≤3s

#### 13.4.1.3. Solder Wetting

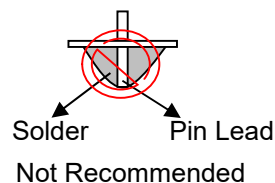
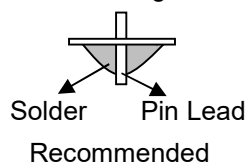

#### 13.4.2. Pins of EL

13.4.2.1. Solder tip can touch and press on the tip of EL leads during soldering.

13.4.2.2. No Solder Paste on the soldering pad on the motherboard is recommended.

13.4.2.3. Recommended Soldering Conditions

Solder type: Nippon Alimit Leadfree SR-34, size 0.5mm

Recommended Solder Temperature: 270~290°C

Typical Soldering Time: ≤2s

Minimum solder distance from EL lamp (body): 2.0mm

13.4.2.4. No horizontal press on the EL leads during soldering.

13.4.2.5. 180° bend EL leads three times is not allowed.

13.4.2.6. Solder Wetting

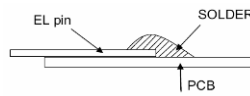

Recommended

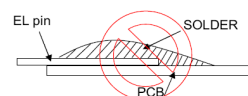

Not Recommended

13.4.2.7. The type of the solder iron:

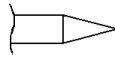

Recommended

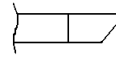

Not Recommended

13.4.2.8. Solder Pad

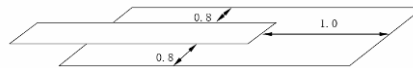

**13.5.Operation**

- 13.5.1. Do not drive LCD with DC voltage
- 13.5.2. Response time will increase below lower temperature
- 13.5.3. Display may change color with different temperature
- 13.5.4. Mechanical disturbance during operation, such as pressing on the display area, may cause the segments to appear “fractured”.
- 13.5.5. Do not connect or disconnect the LCM to or from the system when power is on.
- 13.5.6. Never use the LCM under abnormal condition of high temperature and high humidity.
- 13.5.7. Module has high frequency circuits. Sufficient suppression to the electromagnetic interface shall be done by system manufacturers. Grounding and shielding methods may be important to minimize the interference.
- 13.5.8. Do not display the fixed pattern for long time (we suggest the time not longer than one hour) because it may develop image sticking due to the TFT structure.

**13.6.Static Electricity**

- 13.6.1. CMOS LSIs are equipped in this unit, so care must be taken to avoid the electro-static charge, by ground human body, etc.
- 13.6.2. The normal static prevention measures should be observed for work clothes and benches.
- 13.6.3. The module should be kept into anti-static bags or other containers resistant to static for storage.

**13.7.Limited Warranty**

- 13.7.1. Our warranty liability is limited to repair and/or replacement. We will not be responsible for any consequential loss.
- 13.7.2. If possible, we suggest customer to use up all modules in six months. If the module storage time over twelve months, we suggest that recheck it before the module be used.
- 13.7.3. After the product shipped, any product quality issues must be feedback within three months, otherwise, we will not be responsible for the subsequent or consequential events.