

DISPLAY Elektronik GmbH

DATA SHEET

LCD MODULE

**DEM 480272A4 VMX-PW-N
(A-TOUCH)**

Product Specification

Version: 1

24.03.2022

GENERAL SPECIFICATION

MODULE NO. :

DEM 480272A4

VMX-PW-N(A-TOUCH)

CUSTOMER

VERSION NO.	CHANGE DESCRIPTION	DATE
0	Original version	23.03.2022
1	Change the drawings	24.03.2022

PREPARED BY: YK

DATE: 24.03.2022

APPROVEDBY: WH

DATE: 24.03.2022

CONTENTS

1. GENERAL SPECIFICATIONS.....	2
2. EXTERNAL DIMENSIONS	4
3. BLOCK DIAGRAM	6
4. PIN ASSIGNMENT	7
5. OPTICAL CHARACTERISTICS.....	9
6. ABSOLUTE MAXIMUM RATINGS.....	12
7. ELECTRICAL CHARACTERISTICS.....	13
8. TIMING CHARACTERISTICS.....	14
9. RELIABILITY TEST	17
10. LCD MODULES HANDLING PRECAUTIONS.....	18
11. OTHERS	18

1. GENERAL SPECIFICATIONS

ITEM	STANDARD VALUE	UNIT
LCD SIZE	4.3' TFT	inth
LCD TYPE	TFT/IPS/NORMALLY BLACK/TRANSMISSIVE	
MODULE SIZE	105.50 x 67.20 x 5.75	mm
ACTIVE SIZE	95.04 x 53.86	mm
PIXEL PITCH	0.198 x 0.198	mm
NUMBER OF DOTS	480 x 272	
DRIVER IC	SC7283-G4	
INTERFACE TYPE	8Bit 8080 system interface	
RECOMMENG VIEWING DIRECTION	ALL	O'clock
GRAY SCALE INVERSION DIRECTION	-	O'clock
COLORS	16.7 MILLION	
BACKLIGHT TYPE	7-CHIP WHITE LED	
TOUCH PANEL TYPE	RTP	
LCD CONTROLLER	SSD1963	

Touch Panel Features:

Type:	4-Wire Analogy Resistive Touch Panel
Input Mode:	Stylus or Finger
ITO Film:	0.175 mm (T)
ITO Glass:	0.7 mm (T)
Connector:	FPC

Touch Panel Mechanical Characteristics

Surface Hardness: 3H or more (according to JIS-K5400).

Touch Panel Optical Characteristics

Transmittance: 80% Typical.

Touch Panel Rating**1. Maximum Voltage**

Less than DC 7 volts.

2. Operating Temperature Range

- 30°C to 85°C (Humidity: 20% RH to 70% RH, No condensation of dew).

3. Storage Temperature Range

- 30°C to 85°C (Humidity: 20% RH to 80% RH, No condensation of dew).

Electrical Characteristics**1. Resistance between Terminals**

Direction "X": 430~950Ω

Direction "Y": 140~320Ω

2. Linearity

X axis: $\leq \pm 1.5\%$

Y axis: $\leq \pm 1.5\%$

3. Insulation Resistance: 20MΩ or more at DC 25 V.**4. Chattering Time: 10 msec or less at 100kΩ Pull-up.**

2. EXTERNAL DIMENSIONS

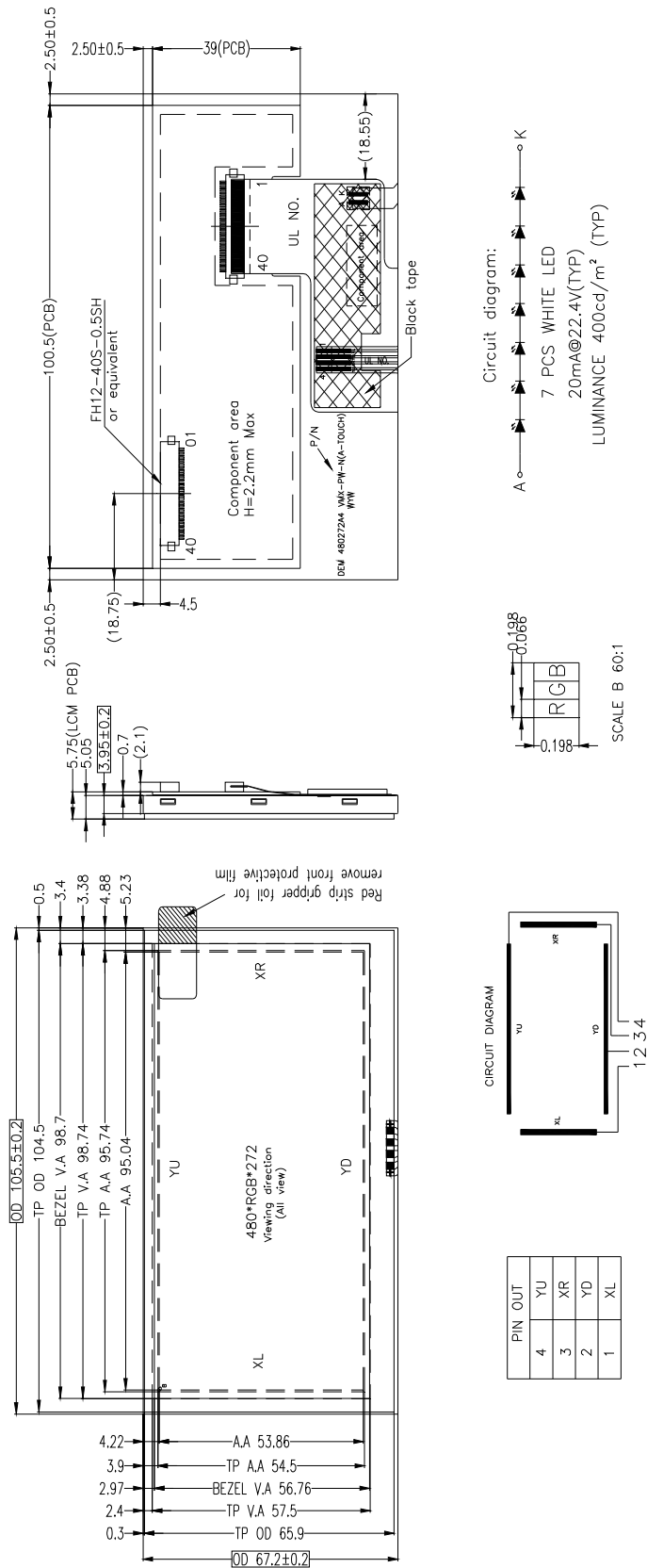

Remark:
 1. Unmarked tolerance is ±0.3
 2. All materials comply with RoHS
 3. []critical dimension
 4. WW:Product date code printing
 Format: Y:year ,WW:week

TOUCH PANEL:

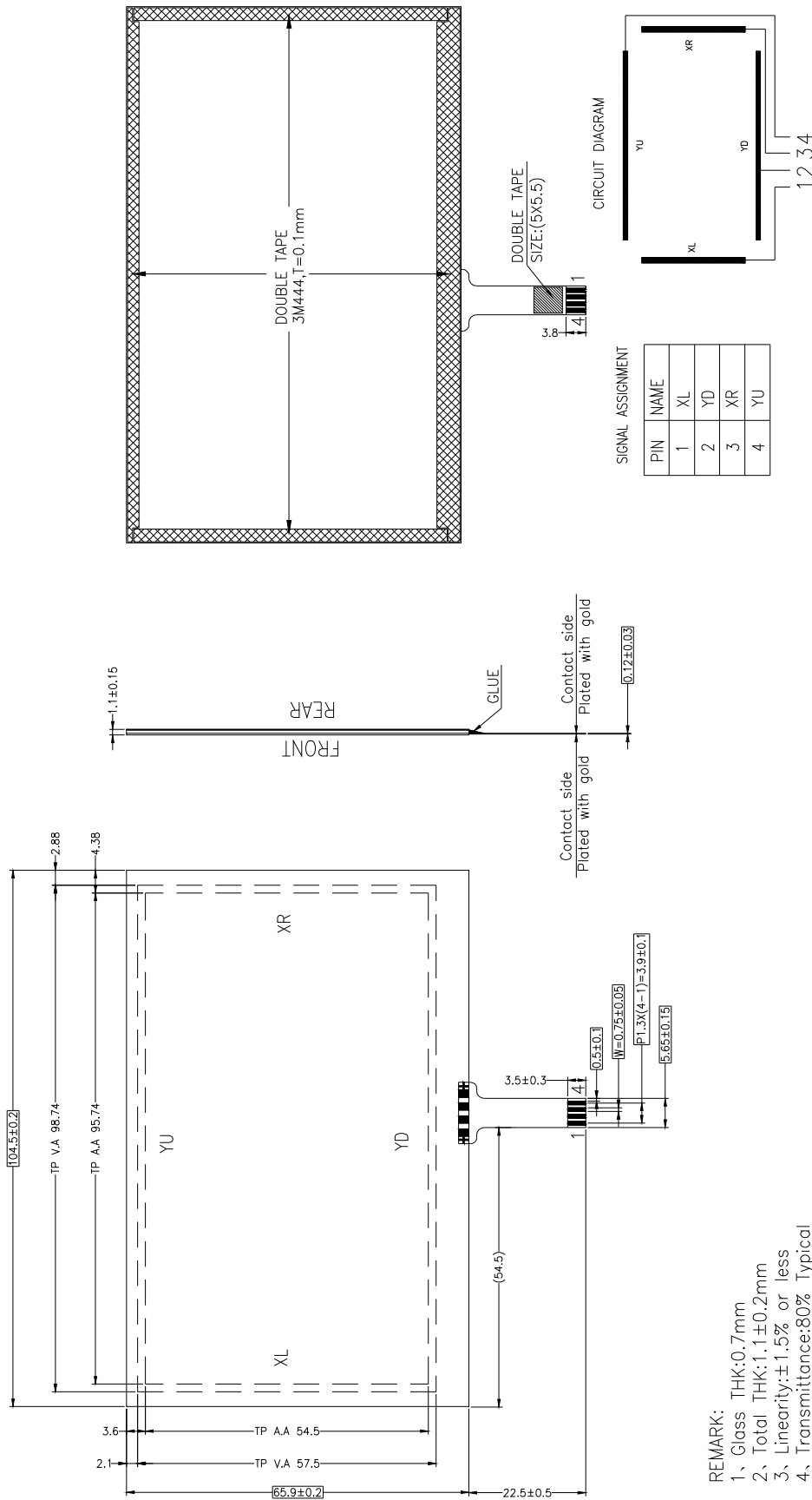

3. BLOCK DIAGRAM

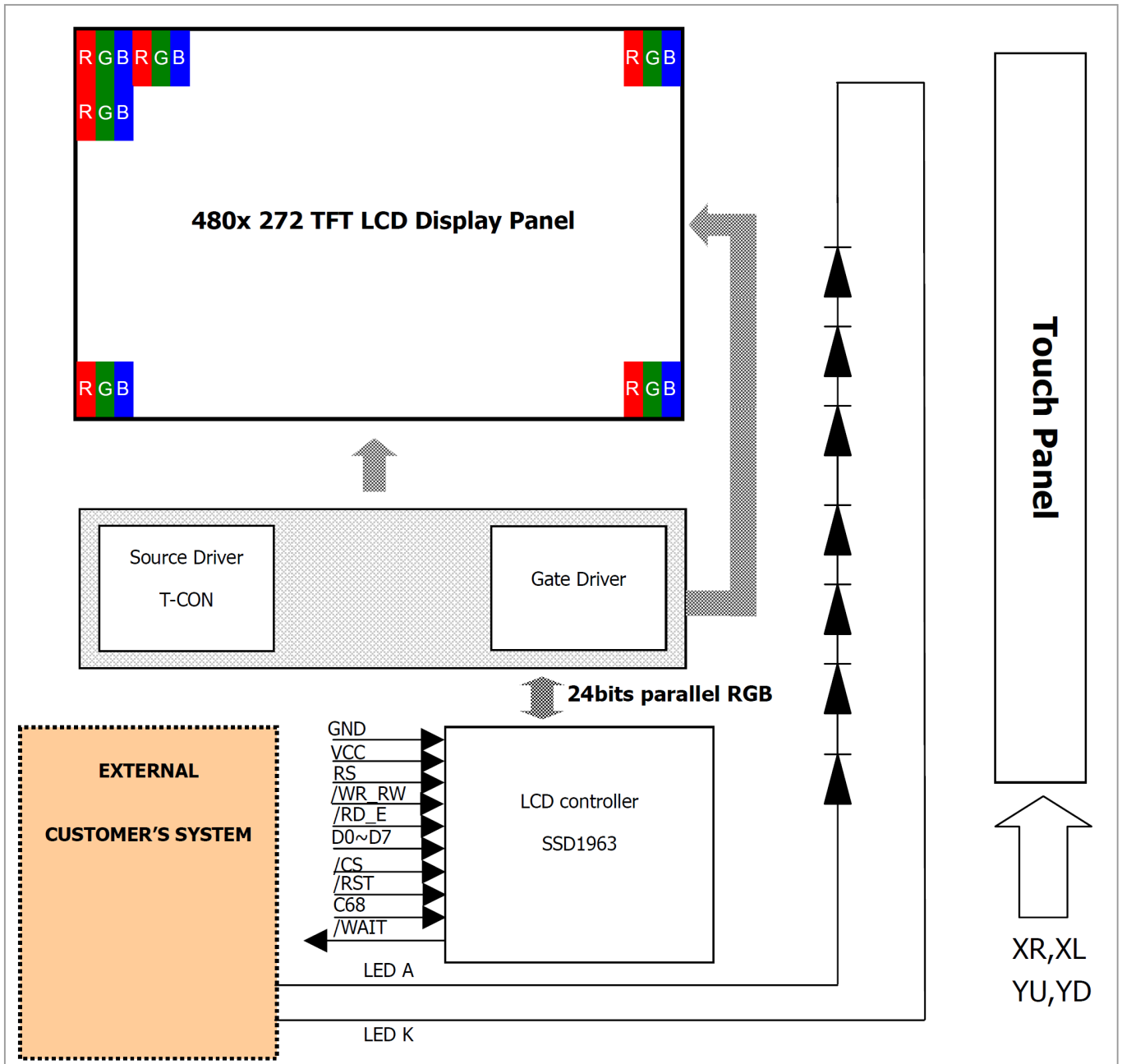

4. PIN ASSIGNMENT

Pin No.	Symbol	I/O	FUNCTION	REMARK
1	VCC	P	Power supply	
2	VCC	P	Power supply	
3	GND	P	GND	
4	GND	P	GND	
5	/RST	I	Reset Signal	
6	NC	-	Not connection	
7	/WAIT	O	Tearing effect	
8	C68	I	MCU Interface configuration I: 8080 Interface	
9	/CS	I	CS: chip select pin	
10	RS	I	Data command select	
11	/RD_E	I	8080 mode:RD#(read strobe signal)	
12	/WR_RW	I	8080 mode:WR#(write strobe signal)	
13	GND	P	GND	
14	DB0	IO	Data bus 0	(1)
15	DB1	IO	Data bus 1	(1)
16	DB2	IO	Data bus 2	(1)
17	DB3	IO	Data bus 3	(1)
18	DB4	IO	Data bus 4	(1)
19	DB5	IO	Data bus 5	(1)
20	DB6	IO	Data bus 6	(1)
21	DB7	IO	Data bus 7	(1)
22	NC	-	Not connection	(1)
23	NC	-	Not connection	(1)
24	NC	-	Not connection	(1)
25	NC	-	Not connection	(1)
26	NC	-	Not connection	(1)
27	NC	-	Not connection	(1)
28	NC	-	Not connection	(1)
29	NC	-	Not connection	(1)
30	GND	P	GND	
31	NC	-	Not connection	
32	NC	-	Not connection	
33	GND	P	GND	

DEM 480272A4 VMX-PW-N(A-TOUCH)**Product Specification**

34	GND	P	GND	
35	XR	O	Touch Panel Pin	
36	YD	O	Touch Panel Pin	
37	XL	O	Touch Panel Pin	
38	YU	O	Touch Panel Pin	
39	LEDA	P	Anode of LED backlight	
40	LEDK	P	Cathode of LED backlight	

Note : DATA Pins not used should be floating

5. OPTICAL CHARACTERISTICS

ITEM		SYMBOL	CONDITIONS	SPECIFICATIONS			UNIT	NOTE	
				MIN	TYP.	MAX			
Luminance		L	Il=20mA	320	400		Cd/m ²		
Contrast ratio		CR	θ =0° VIEWING NORMAL ANGLE	640	800				
Response time		Ton + Toff			30	40	ms		
CIE COLOUR COORDINATE		RED		XR		0.629			
				YR		0.326			
		GREEN		XG		0.337			
				YG		0.546			
		BLUE		XB		0.136			
				YB		0.143			
		WHITE		XW		0.320			
				YW		0.345			
VIEWING ANGLE		Hor.	θ x+	70	80		Degree		
			θ x-	70	80				
		Ver.	θ y+	70	80				
			θ y-	70	80				

Note 1: Definition of Viewing Angle θ_x and θ_y :

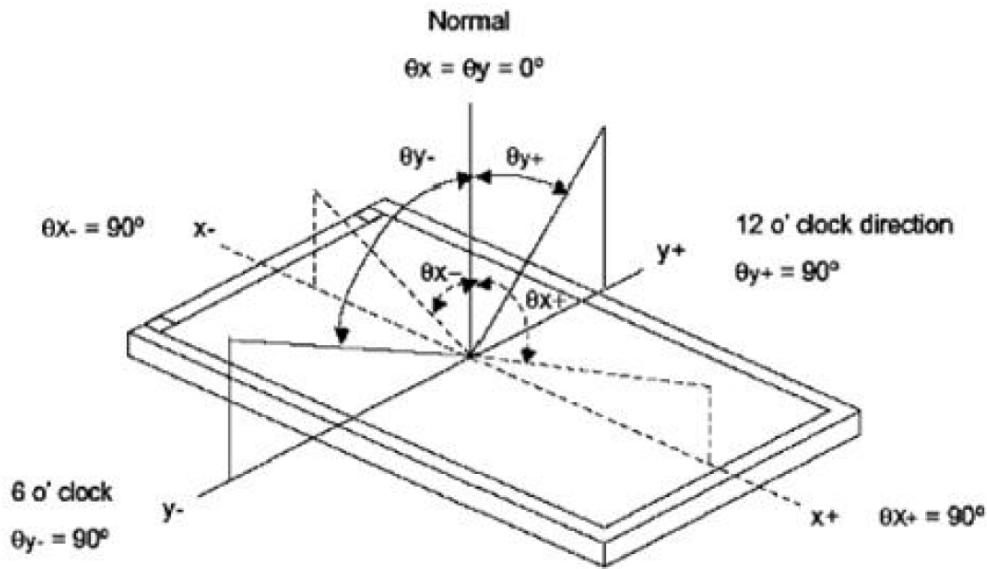

Note 2: Definition of contrast ratio CR:

$$CR = \frac{\text{Luminance of white state}}{\text{Luminance of black state}}$$

Note 3: Definition of Response Time (T_r, T_f)

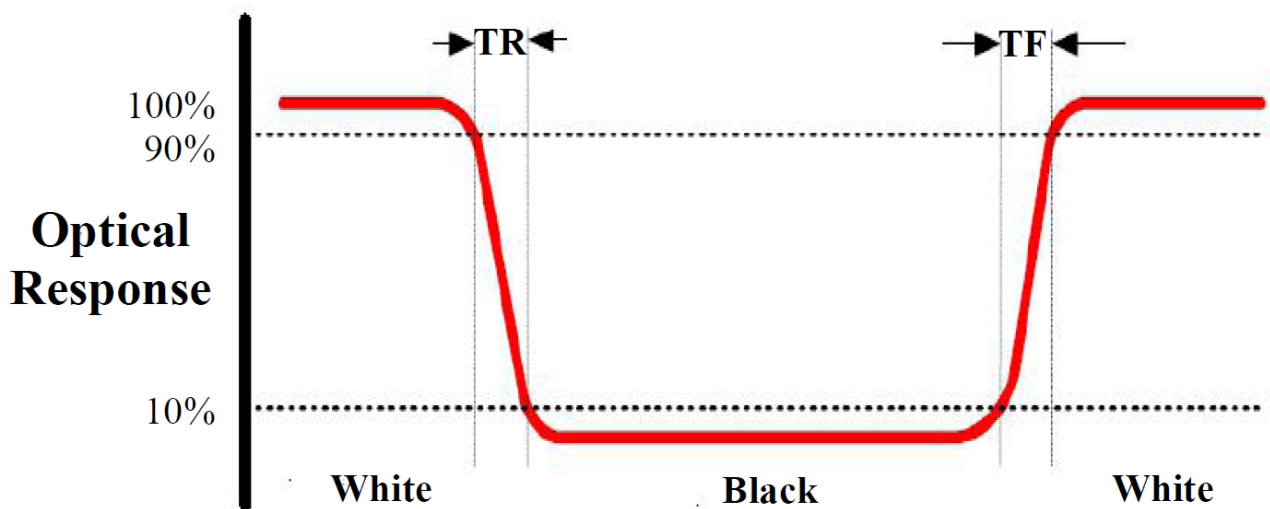

Note 4: Definition of Luminance

① The Brightness Test Equipment Setup

Field=2° (As measuring “black” image, field=2° is the best testing condition)

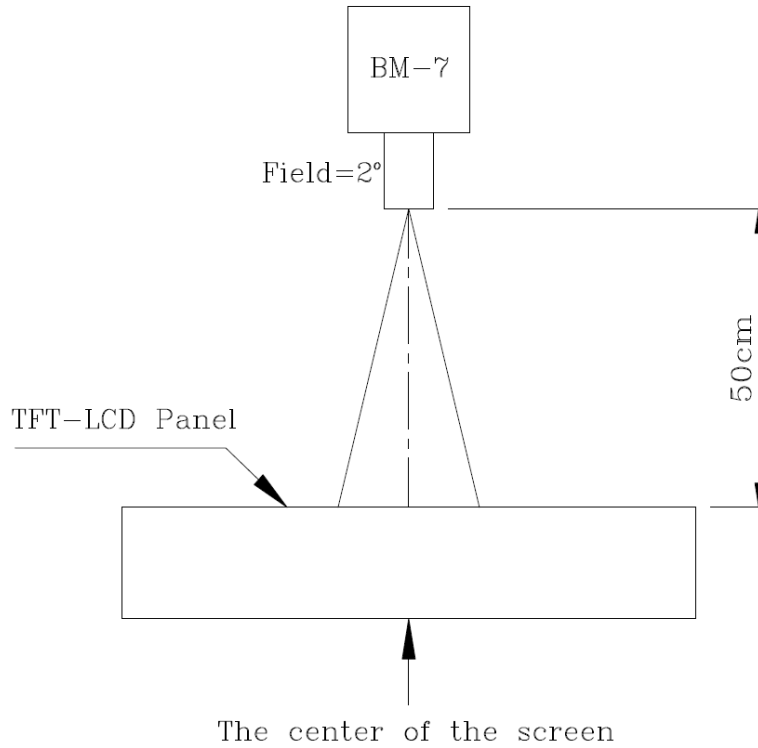

② The Brightness Test Point Setup

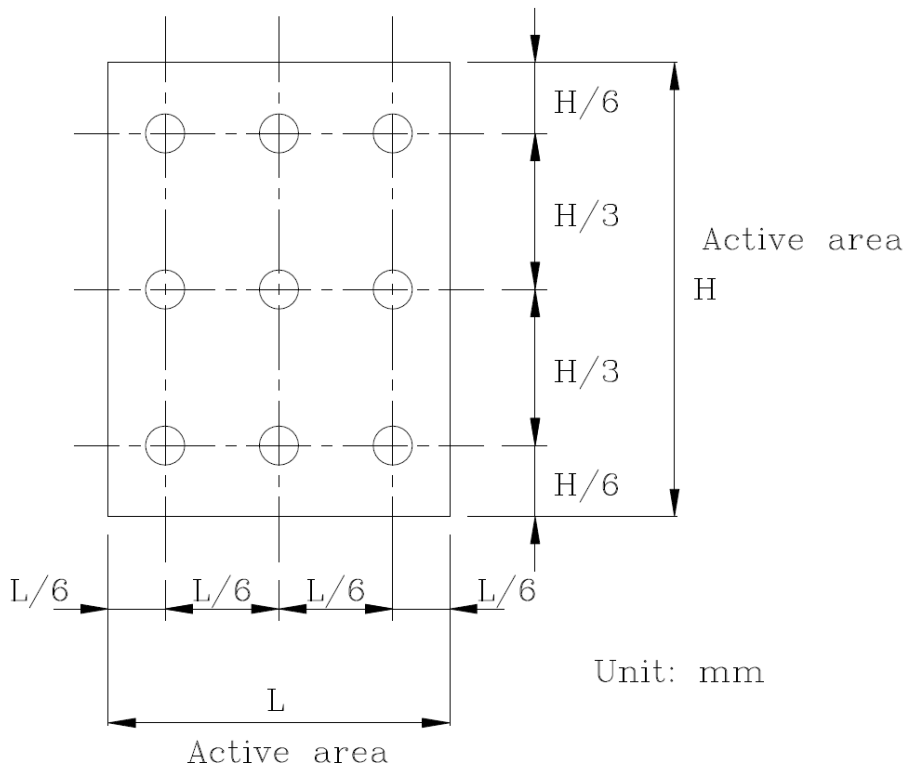

6. ABSOLUTE MAXIMUM RATINGS

PARAMETER	SYMBOL	MIN	MAX	UNIT
Power Supply Voltage	VDD	-0.3	4.0	V
IO Supply Voltage	VDDI	-0.3	4.0	V
Supply Current(one LED)	I(LED)		30	mA
Operating Temperature	Top	-30	+85	°C
Storage Temperature	Tst	-30	+85	°C

Note: The absolute maximum rating values of this product are not allowed to be exceeded at any times. Should a module be used with any of the absolute maximum ratings exceeded, the characteristics of the module may not be recovered, or in an extreme case, the module may be permanently destroyed.

7. ELECTRICAL CHARACTERISTICS**7.1 Input Power**

ITEM	SYMBOL	MIN	TYP.	MAX	UNIT
Power Supply Voltage	VDD	3.0	3.3	3.6	V
IO Supply Voltage	VDDI	3.0	3.3	3.6	V
Input Voltage	Vil	GND	-	0.3VDDI	V
	Vih	0.7VDDI	-	VDDI	V

7.2 Backlight Driving Conditions

ITEM	SYMBOL	SPECIFICATIONS			UNIT	REMARK
		MIN	TYP.	MAX		
Voltage for LED Backlight	Vf	20.3	22.4	23.8	V	I _l =20mA
Current for LED Backlight	I _l	15	20	25	mA	
Power Consumption	P		0.448		W	
Led Lifetime			50,000		Hr	Note

Note: brightness to be decreased to 50% of the initial value at ambient temperature TA=25°C

8. TIMING CHARACTERISTICS

8.1 RGB Interface — SYNC Mode

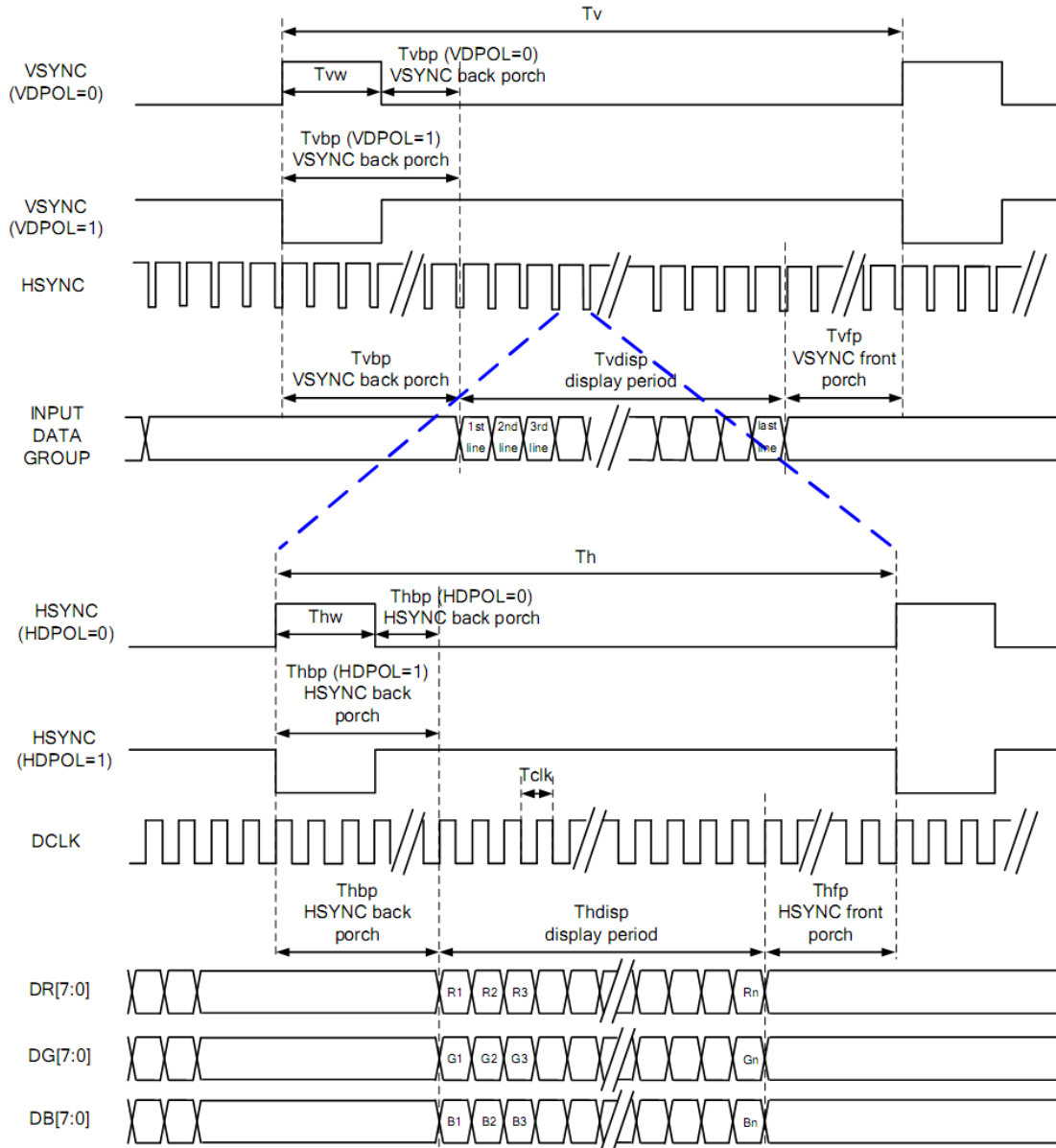

8.2 Parallel 24 bit RGB Input Timing Table

Parallel 24-bit RGB Input Timing (PVDD=VDD=VDDI= 3.3V, AGND= 0V, TA=25°C)

480RGB X 272 Resolution Timing Table							
Item	Symbol	Min.	Typ.	Max.	Unit	Remark	
DCLK Frequency	Fclk	8	9	12	MHz		
DCLK Period	Tclk	83	111	125	ns		
HSYNC	Period Time	Th	485	531	598	DCLK	
	Display Period	Thdisp		480		DCLK	
	Back Porch	Thbp	3	43	43	DCLK	By H_BLANKING setting
	Front Porch	Thfp	2	8	75	DCLK	
	Pulse Width	Thw	2	4	43	DCLK	
VSYNC	Period Time	Tv	276	292	321	HSYNC	
	Display Period	Tvdisp		272		HSYNC	
	Back Porch	Tvbp	2	12	12	HSYNC	By V_BLANKING setting
	Front Porch	Tvfp	2	8	37	HSYNC	
	Pulse Width	Tvw	2	4	12	HSYNC	

Note: It is necessary to keep Tvbp =12 and Thbp =43 in sync mode. DE mode is unnecessary to keep it.

8.3 Parallel 8080-series Interface Timing Characteristics

Symbol	Parameter	Min	Typ	Max	Unit	
f _{MCLK}	System Clock Frequency*	1	-	110	MHz	
t _{MCLK}	System Clock Period*	1/ f _{MCLK}	-	-	ns	
t _{PWCSL}	Control Pulse High Width	Write	13	1.5* t _{MCLK}	-	ns
		Read	30	3.5* t _{MCLK}		
t _{PWCSH}	Control Pulse Low Width	Write (next write cycle)	13	1.5* t _{MCLK}	-	ns
		Write (next read cycle)	80	9* t _{MCLK}		
		Read	80	9* t _{MCLK}		
t _{AS}	Address Setup Time	1	-	-	ns	
t _{AH}	Address Hold Time	2	-	-	ns	
t _{DSW}	Write Data Setup Time	4	-	-	ns	
t _{DHW}	Write Data Hold Time	1	-	-	ns	
t _{PWLW}	Write Low Time	12	-	-	ns	
t _{DHR}	Read Data Hold Time	1	-	-	ns	
t _{ACC}	Access Time	32	-	-	ns	
t _{PWLR}	Read Low Time	36	-	-	ns	
t _R	Rise Time	-	-	0.5	ns	
t _F	Fall Time	-	-	0.5	ns	
t _{CS}	Chip select setup time	2	-	-	ns	
t _{CSH}	Chip select hold time to read signal	3	-	-	ns	

* System Clock denotes external input clock (PLL-bypass) or internal generated clock (PLL-enabled)

8.4 Parallel 8080-series Interface Timing Diagram(Write Cycle)

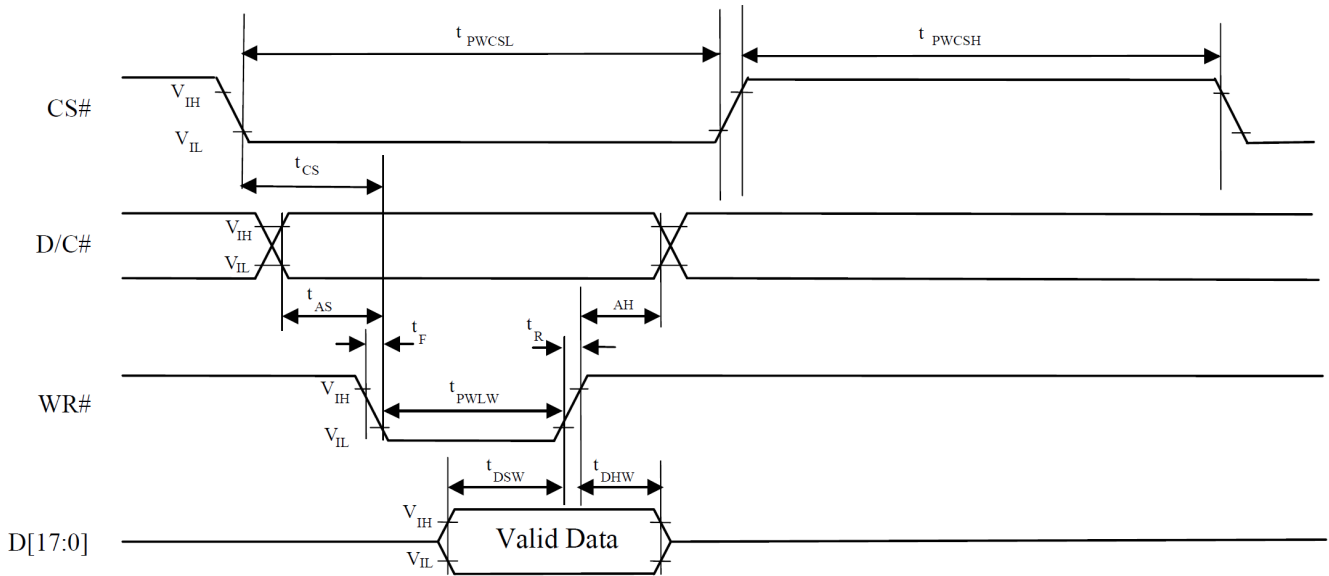

8.5 Parallel 8080-series Interface Timing Diagram(Read Cycle)

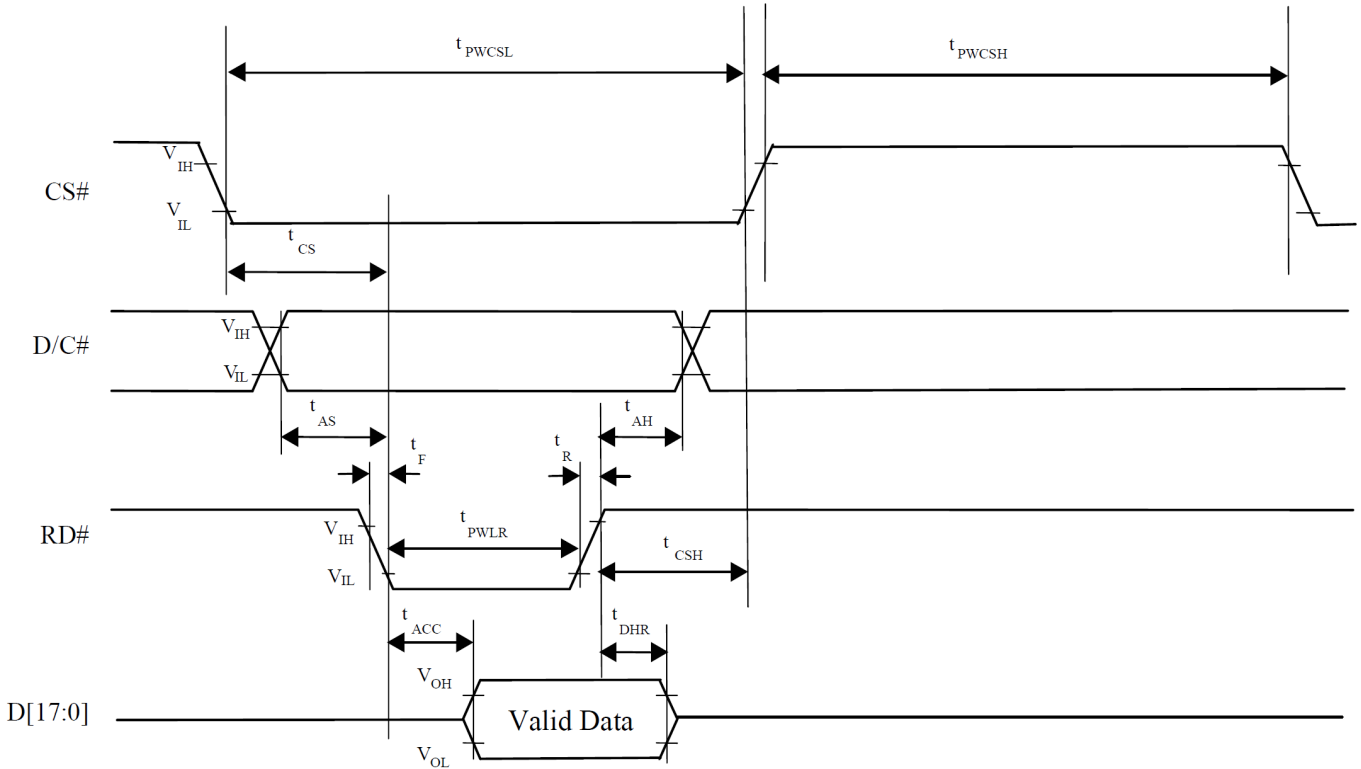

8.6 Mapping for writing an Pixel Data

Interface	Cycle	D[23]	D[22]	D[21]	D[20]	D[19]	D[18]	D[17]	D[16]	D[15]	D[14]	D[13]	D[12]	D[11]	D[10]	D[9]	D[8]	D[7]	D[6]	D[5]	D[4]	D[3]	D[2]	D[1]	D[0]			
8 bits	1 st																			R7	R6	R5	R4	R3	R2	R1	R0	
	2 nd																				G7	G6	G5	G4	G3	G2	G1	G0
	3 rd																				B7	B6	B5	B4	B3	B2	B1	B0

9. RELIABILITY TEST

NO.	TEST ITEM	DESCRIPTION
1	High Temperature Operation	Ta=+85°C, 240hrs
2	Low Temperature Operation	Ta=-30°C, 240hrs
3	High Temperature Storage	Ta=+85°C, 240hrs
4	Low Temperature Storage	Ta=-30°C, 240hrs
5	High Temperature and High Humidity (Operating)	Ta=+60°C, 90%RH, 240hrs

10. LCD MODULES HANDLING PRECAUTIONS

- n** The display panel is made of glass. Do not subject it to a mechanical shock by dropping it from a high place, etc.
- n** If the display panel is damaged and the liquid crystal substance inside it leaks out, do not get any in your mouth. If the substance come into contact with your skin or clothes promptly wash it off using soap and water.
- n** Do not apply excessive force to the display surface or the adjoining areas since this may cause the color tone to vary.
- n** The polarizer covering the display surface of the LCD module is soft and easily scratched. Handle this polarize carefully.
- n** To prevent destruction of the elements by static electricity, be careful to maintain an optimum work environment.
 - Be sure to ground the body when handling the LCD module.
 - Tools required for assembly, such as soldering irons, must be properly grounded.
 - To reduce the amount of static electricity generated, do not conduct assembly and other work under dry conditions.
 - The LCD module is coated with a film to protect the display surface. Exercise care when peeling off this protective film since static electricity may be generated.
- n** Storage precautions
When storing the LCD modules, avoid exposure to direct sunlight or to the light of fluorescent lamps. Keep the modules in bags designed to prevent static electricity charging under low temperature / normal humidity conditions (avoid high temperature / high humidity and low temperatures below 0°C).Whenever possible, the LCD modules should be stored in the same conditions in which they were shipped from our company.

11. OTHERS

- n** Liquid crystals solidify at low temperature (below the storage temperature range) leading to defective orientation of liquid crystal or the generation of air bubbles (black or white). Air bubbles may also be generated if the module is subjected to a strong shock at a low temperature.
- n** If the LCD modules have been operating for a long time showing the same display patterns may remain on the screen as ghost images and a slight contrast irregularity may also appear. Abnormal operating status can be resumed to be normal condition by suspending use for some time. It should be noted that this phenomena does not adversely affect performance reliability.
- n** To minimize the performance degradation of the LCD modules resulting from caused by static electricity, etc. exercise care to avoid holding the following sections when handling the modules:
 - Exposed area of the printed circuit board
 - Terminal electrode sections.