

Display Elektronik GmbH

# DATA SHEET

*TFT MODULE*

**DEM 480480D VMX-PW-N  
(A-TOUCH)**

**4,0“ TFT**

Product Specification

Version: 0

09.11.2021

## Revision History

<b>VERSION</b>	<b>DATE</b>	<b>REVISED PAGE NO.</b>	<b>Note</b>
0	09.11.2021		First Issue

# Contents

- 1.Summary
- 2.General Specifications
- 3.Interface
- 4.Contour Drawing
- 5.Absolute Maximum Ratings
- 6.Electrical Characteristics
- 7.Function Description
- 8.Optical Characteristics
- 9.Reliability
- 10.Touch Panel Information
- 11.Initial Code For Reference

## 1. Summary

TFT 4.0" is a color active matrix thin film transistor (TFT) liquid crystal display (LCD) that uses amorphous silicon TFT as a switching device. This TFT LCD has a 4.0 (1:1) inch diagonally measured active display area with 480x480 (480 horizontal by 480 vertical pixel) resolution.

## 2. General Specifications

n Size:	4.0 Inch
n Dot Matrix:	480 (RGB) x 480 dots
n Module Dimension:	78.80 x 82.95 x 6.37 mm
n Active Area:	71.856 x 70.176 mm
n Pixel Pitch:	0.1497 x 0.1462 mm
n LCD Type:	TFT, Normally Black, Transmissive
n View Direction:	80/80/80/80
n Aspect Ratio:	1:1
n Interface:	24-bit RGB
n Driver IC:	ST7701S or Equivalent
n Backlight Type:	LED ,Normally White
n With /Without TP:	With RTP
n Surface:	Anti-Glare

\*Color tone slight changed by temperature and driving voltage.

### 3.Interface

#### 3.1. LCM PIN Definition

Pin	Symbol	Function
1	VLED-	Power for LED backlight cathode
2	VLED+	Power for LED backlight anode
3	GND	Power ground
4	VCC	Power supply
5	R0	Data bus
6	R1	
7	R2	
8	R3	
9	R4	
10	R5	
11	R6	
12	R7	
13	G0	Data bus
14	G1	
15	G2	
16	G3	
17	G4	
18	G5	
19	G6	
20	G7	
21	B0	Data bus
22	B1	
23	B2	
24	B3	
25	B4	
26	B5	
27	B6	
28	B7	
29	SCL	SCL: Serial clock input for SPI interface.
30	PCLK	Dot clock signal for RGB interface operation
31	CS	- A chip select signal

		Low: the chip is selected and accessible High: the chip is not selected and not accessible
32	HSYNC	Line synchronizing signal for RGB interface operation
33	VSYNC	Frame synchronizing signal for RGB interface operation
34	DE	Data enable signal for RGB interface operation Low: access enabled High: access inhibited
35	SDA	SDA: Serial data input/output bidirectional pin for SPI Interface.
36	RESET	- The external reset input - Initializes the chip with a low input. Be sure to execute a power-on reset after supplying power.
37	XR	Top ITO Film Terminal
38	YD	Bottom ITO Glass Terminal
39	XL	Top ITO Film Terminal
40	YU	Bottom ITO Glass Terminal

### 4. Contour Drawing

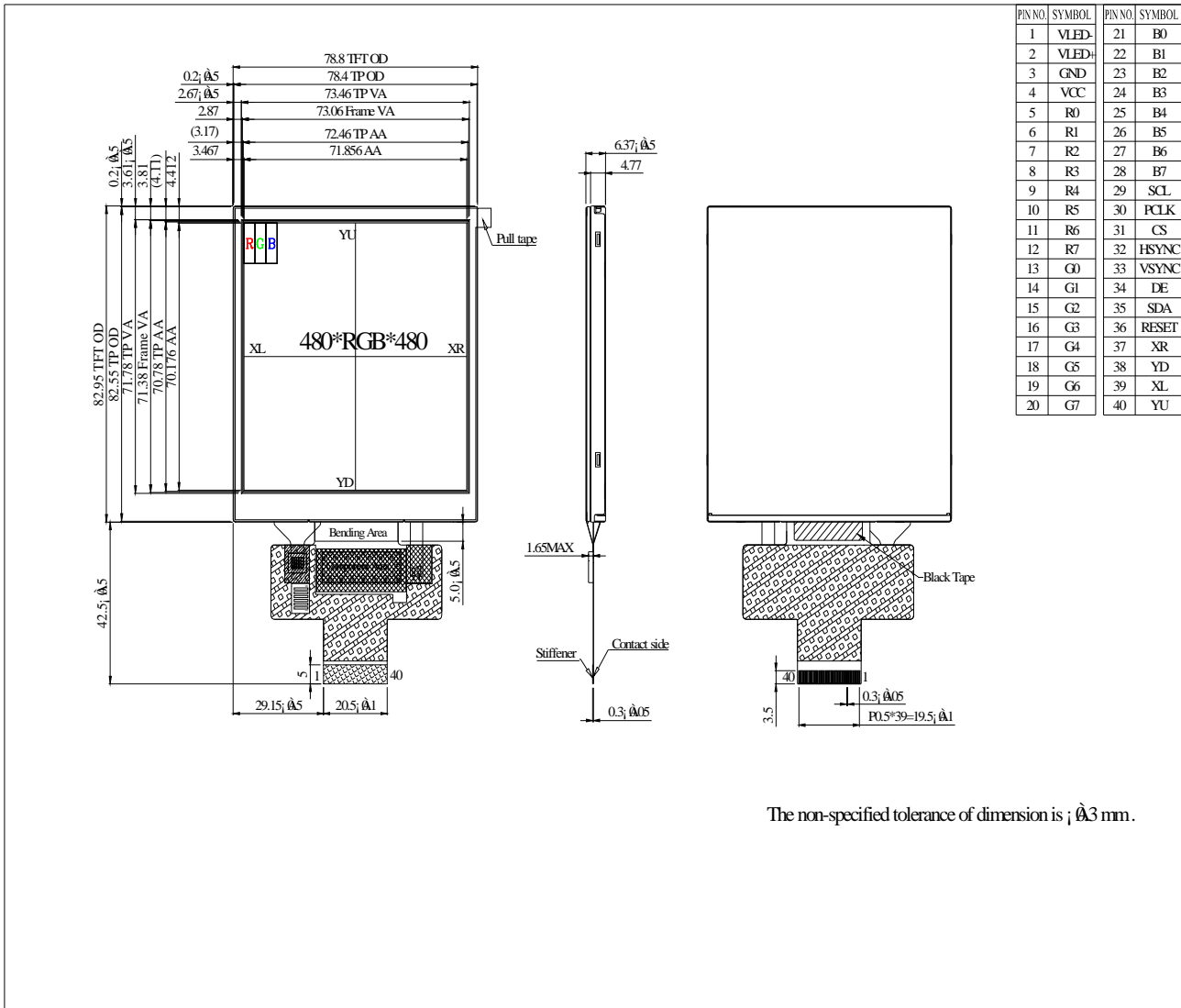

## 5. Absolute Maximum Ratings

Item	Symbol	Min	Typ	Max	Unit
Operating Temperature	TOP	-30	-	+80	°C
Storage Temperature	TST	-30	-	+80	°C

Note: Device is subject to be damaged permanently if stresses beyond those absolute maximum ratings listed above

- Temp. □60°C, 90% RH MAX. Temp. > 60°C, Absolute humidity shall be less than 90% RH at 60°C

## 6. Electrical Characteristics

### 6.1. Typical Operation Conditions

Item	Symbol	Values			Unit	Remark
		Min.	Typ.	Max.		
Interface Supply Voltage	VCC	2.5	2.8	3.6	V	
Current for Driver(White)	Ivcc	-	27	40.5	mA	

### 6.2. Backlight Driving Conditions

Parameter	Symbol	Min.	Typ.	Max.	Unit	Remark
LED Current	I <sub>LED</sub>	-	120	-	mA	
LED Voltage	V <sub>LED+</sub>	13.5	15	17	V	Note 1
LED Lifetime		50,000	-	-	Hr	Note 2,3,4

Note 1 : There are 1 Groups LED

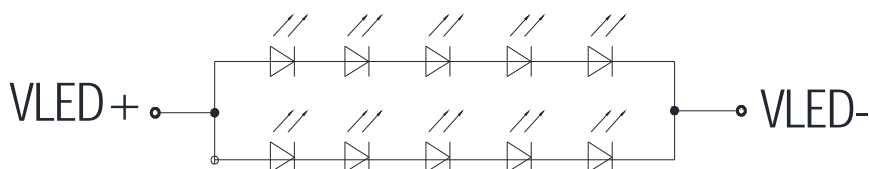

CIRCUIT DIAGRAM

Note 2 : Ta = 25 °C

Note 3 : Brightness to be decreased to 50% of the initial value

Note 4 : The single LED lamp case.



## 7.Function Description

### 7.1. RGB Interface

The ST7701S support RGB interface Mode 1 and Mode 2.

The Mode 1 and Mode 2 function is select by setting in the Command 2, please reference application note.

In RGB Mode 1, writing data to line buffer is done by PCLK and Video Data Bus (D[23:0]), when DE is high state. The external clocks (PCLK, VS and HS) are used for internal displaying clock. So, controller must always transfer PCLK, VS and HS signal to ST7701S.

In RGB Mode 2, back porch of Vsync is defined by VBP\_HVRGB [7:0] of RGBCTR command. And back porch of Hsync is defined by HBP\_HVRGB [7:0] of RGBCTR command. Front porch of Vsync are not setting by this mode.

RGB I/F Mode	PCLK	DE	VS	HS	DB[23:0]	Register for Blanking Porch setting
RGB Mode 1	Used	Used	Used	Used	Used	Not Used
RGB Mode 2	Used	Not Used	Used	Used	Used	Used

Symbol	Name	Description
PCLK	Pixel clock	Pixel clock for capturing pixels at display interface
HS	Horizontal sync	Horizontal synchronization timing signal
VS	Vertical sync	Vertical synchronization timing signal
DE	Data enable	Data enable signal (assertion indicates valid pixels)
DB[23:0]	Pixel data	Pixel data in 16-bit, 18-bit and 24-bit format

Table 1 The interface signals of RGB interface

**7.2. RGB Color Format**

ST7701S supports two kinds of RGB interface, DE mode(mode 1)and HV mode(mode 2), and 16bit/18bitand 24 bit data format. When DE mode is selected and the VSYNC, HSYNC, DOTCLK, DE, D[23:0] pins can be used; when HV mode is selected and the VSYNC, HSYNC, DOTCLK, D[23:0] pins can be used. When using RGB interface, only serial interface can be selected.

Pad name	24 bits configuration VIPF[3:0]=0111	18 bits configuration VIPF[3:0]=0110		16 bits configuration VIPF[3:0]=0101
		MDT=0	MDT=1	
DB[23]	R7	Not used	Not used	Not used
DB[22]	R6	Not used	Not used	Not used
DB[21]	R5	R5	Not used	Not used
DB[20]	R4	R4	Not used	R4
DB[19]	R3	R3	Not used	R3
DB[18]	R2	R2	Not used	R2
DB[17]	R1	R1	R5	R1
DB[16]	R0	R0	R4	R0
DB[15]	G7	Not used	R3	Not used
DB[14]	G6	Not used	R2	Not used
DB[13]	G5	G5	R1	G5
DB[12]	G4	G4	R0	G4
DB[11]	G3	G3	G5	G3
DB[10]	G2	G2	G4	G2
DB[09]	G1	G1	G3	G1
DB[08]	G0	G0	G2	G0
DB[07]	B7	Not used	G1	Not used
DB[06]	B6	Not used	G0	Not used
DB[05]	B5	B5	B5	Not used
DB[04]	B4	B4	B4	B4
DB[03]	B3	B3	B3	B3
DB[02]	B2	B2	B2	B2
DB[01]	B1	B1	B1	B1
DB[00]	B0	B0	B0	B0

Table 2 The interface color mapping of RGB interface

7.3. RGB Interface Definition

The display operation via the RGB interface is synchronized with the VSYNC, HSYNC, and DOTCLK signals. The data can be written only within the specified area with low power consumption by using window address function. The back porch and front porch are used to set the RGB interface timing.

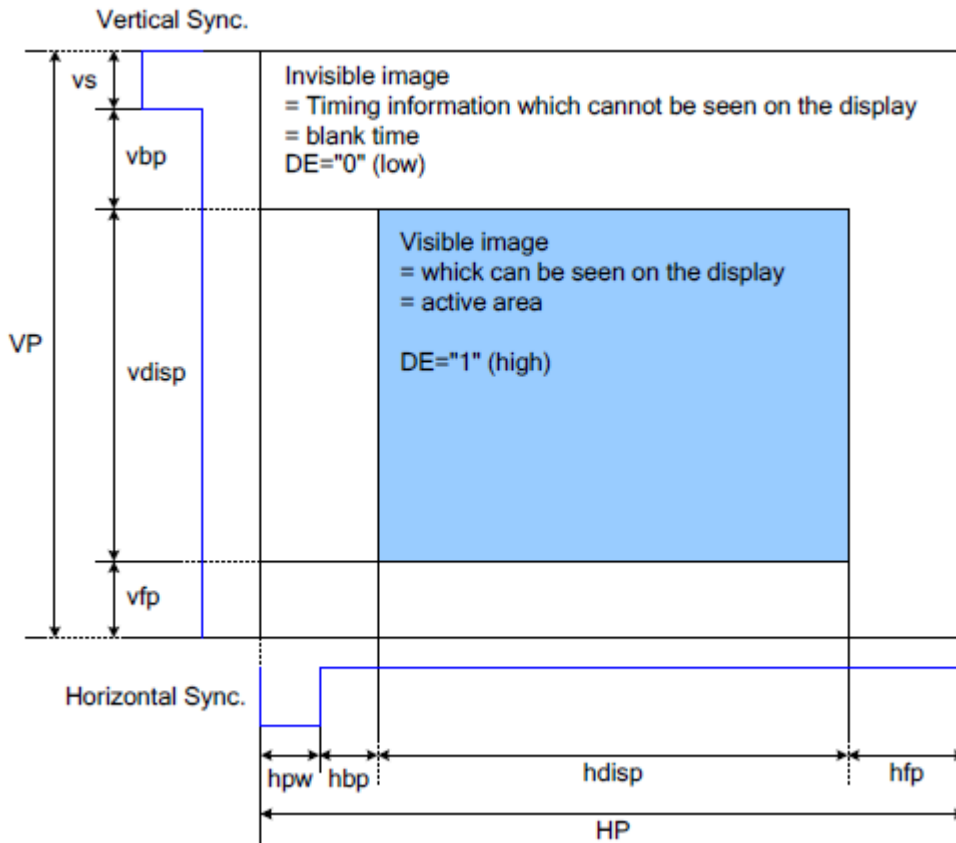

Figure 1 Access Area by RGB Interface

Please refer to the following table for the setting limitation of RGB interface signals.

Parameter	Symbol	Min.	Typ.	Max.	Unit
Horizontal Sync. Width	hbw	2	-	255	Clock
Horizontal Sync. Back Porch	hbp	2	-	255	Clock
Horizontal Sync. Front Porch	hfp	2	-	-	Clock
Vertical Sync. Width	vs	2	-	254	Line
Vertical Sync. Back Porch	vbp	2	-	254	Line
Vertical Sync. Front Porch	vfp	2	-	-	Line

Note:

1. Typical value are related to the setting frame rate is 60Hz..

**7.4. RGB Interface Mode Selection**

ST7701S supports two kinds of RGB interface, DE mode and HV mode. The table shown below uses command C3h to select RGB interface mode.

DE/Sync	RGB Mode
0	DE mode
1	HV mode

**7.5. RGB Interface Timing**

The timing chart of RGB interface DE mode is shown as follows.

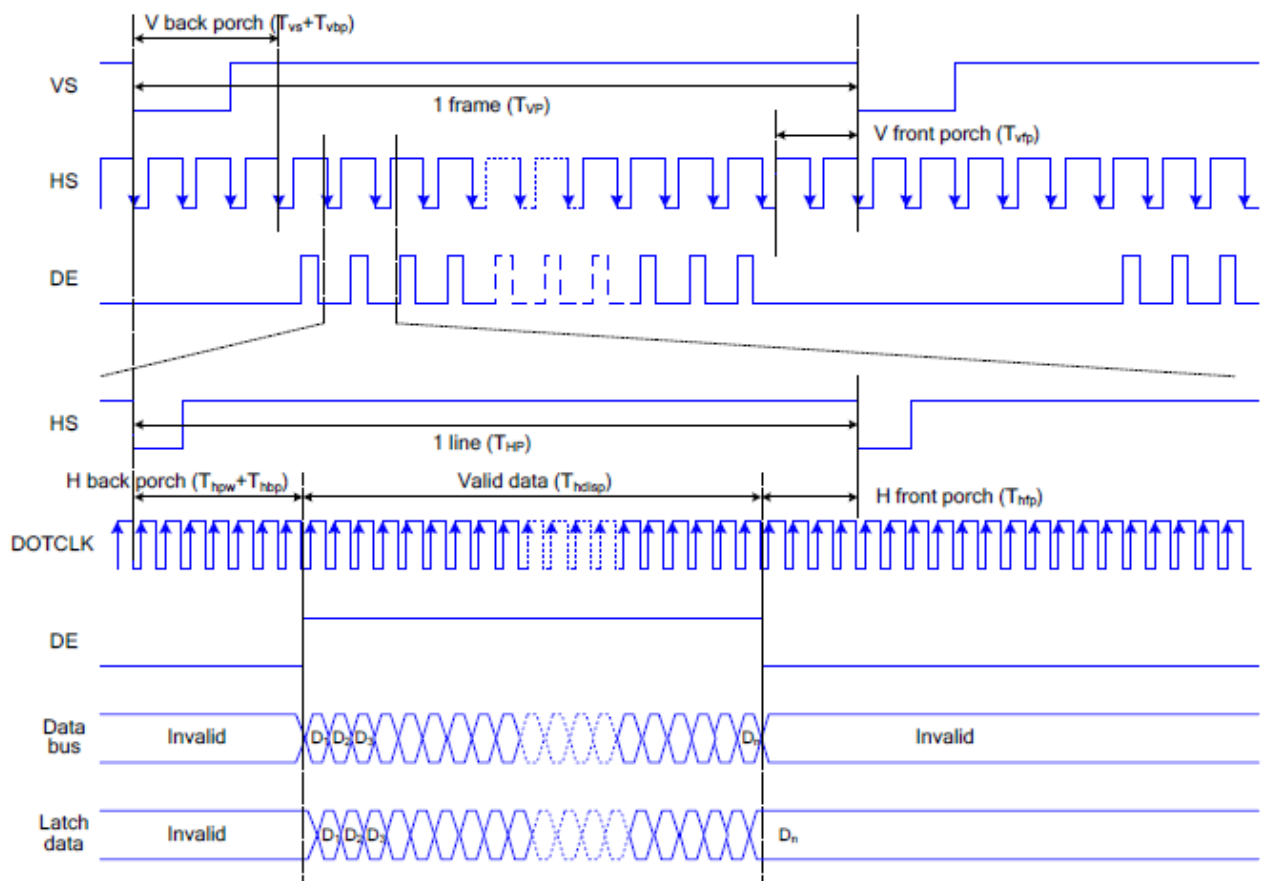

Note: The setting of front porch and back porch in host must match that in IC as this mode.

**Figure 2 Timing Chart of Signals in RGB Interface DE Mode**

The timing chart of RGB interface HV mode is shown as follows.

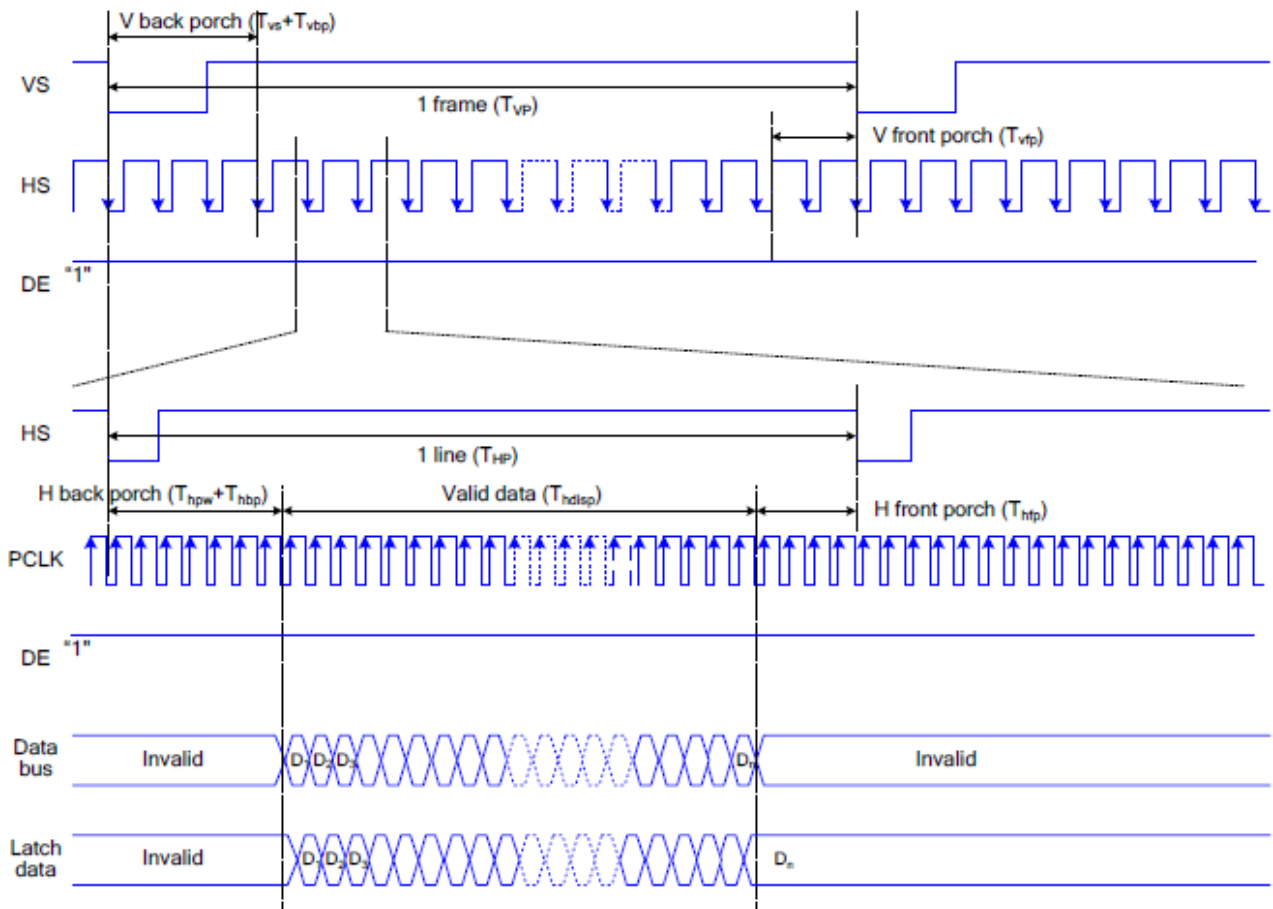

**Figure 3 Timing chart of RGB interface HV mod**

### 8.Optical Characteristics

Item	Symbol	Condition.	Min	Typ.	Max.	Unit	Remark	
Response Time	Tr+ Tf	$\theta=0^\circ$ 、 $\Phi=0^\circ$	-	25	35	.ms	Note 3	
Contrast Ratio	CR	At optimized viewing angle	640	800	-	-	Note 4	
Color Chromaticity	White	Wx	$\theta=0^\circ$ 、 $\Phi=0$	0.251	0.301	0.351		Note 2,6,7
		Wy		0.277	0.327	0.377		
Viewing Angle	Hor.	$\Theta_R$	$CR \geq 10$	70	80	-	Deg.	Note 1
		$\Theta_L$		70	80	-		
	Ver.	$\Phi_T$		70	80	-		
		$\Phi_B$		70	80	-		
Brightness	-	-	600	700	-	cd/m <sup>2</sup>	Center of display	
Uniformity	(U)	-	75	-	-	%	Note 5	

Ta=25±2°C

Note 1: Definition of viewing angle range

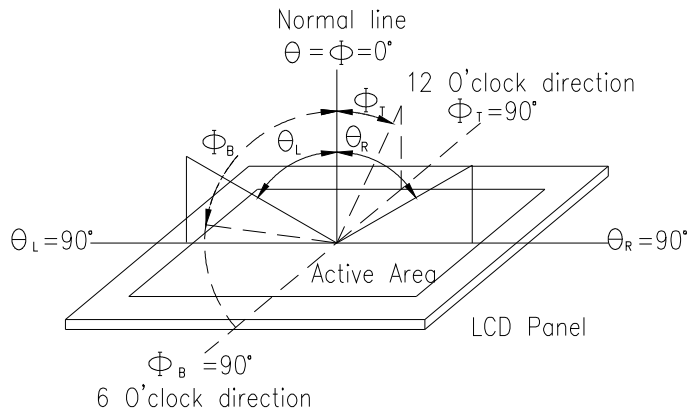
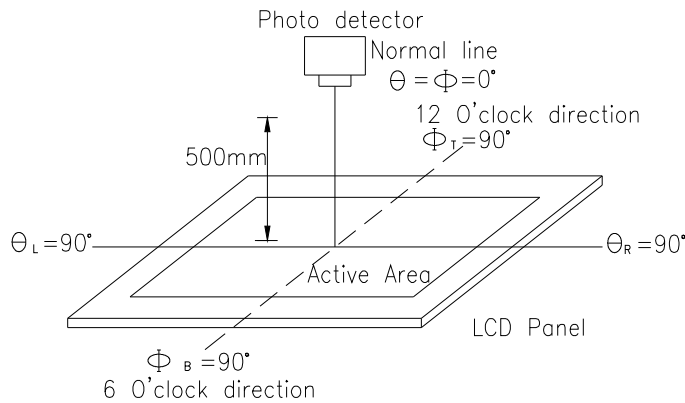

Fig. 9.1. Definition of viewing angle

Note 2: Test equipment setup:

After stabilizing and leaving the panel alone at a driven temperature for 10 minutes, the measurement should be executed. Measurement should be executed in a stable, windless, and dark room. Optical specifications are measured by Topcon BM-7or BM-5 luminance meter 1.0° field of view at a distance of 50cm and normal direction.



**Fig. 9.2. Optical measurement system setup**

**Note 3: Definition of Response time:**

The response time is defined as the LCD optical switching time interval between “White” state and “Black” state. Rise time,  $T_r$ , is the time between photo detector output intensity changed from 90% to 10%. And fall time,  $T_f$ , is the time between photo detector output intensity changed from 10% to 90%

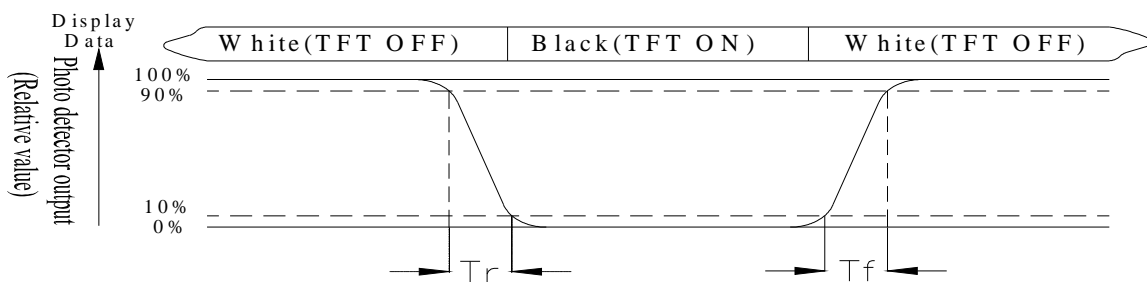

**Note 4: Definition of contrast ratio:**

The contrast ratio is defined as the following expression.

$$\text{Contrast ratio (CR)} = \frac{\text{Luminance measured when LCD on the "White" state}}{\text{Luminance measured when LCD on the "Black" state}}$$

Note 5: Definition of Luminance Uniformity

Active area is divided into 9 measuring areas (reference the picture in below). Every measuring point is placed at the center of each measuring area.

Luminance Uniformity (U) =  $L_{min}/L_{max} \times 100\%$

L = Active area length

W = Active area width

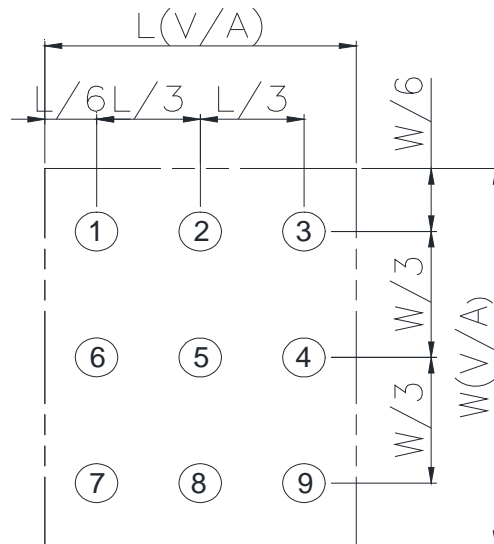

Fig 9.3. Definition of uniformity

Note 6: Definition of color chromaticity (CIE 1931)

Color coordinates measured at the center point of LCD

Note 7: Measured at the center area of the panel when all the input terminals of LCD panel are electrically opened.



## 9. Reliability

Content of Reliability Test (Super Wide temperature, -30°C~80°C)

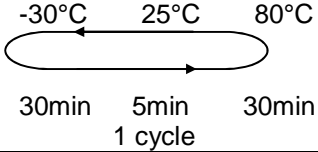
Environmental Test			
Test Item	Content of Test	Test Condition	Note
High Temperature Storage	Endurance test applying the high storage temperature for a long time.	80°C 200hrs	2
Low Temperature Storage	Endurance test applying the low storage temperature for a long time.	-30°C 200hrs	1,2
High Temperature Operation	Endurance test applying the electric stress (Voltage & Current) and the thermal stress to the element for a long time.	80°C 200hrs	—
Low Temperature Operation	Endurance test applying the electric stress under low temperature for a long time.	-30°C 200hrs	1
High Temperature/ Humidity Storage	The module should be allowed to stand at 60□,90%RH max	60°C,90%RH 96hrs	1,2
Thermal Shock Resistance	The sample should be allowed stand the following 10 cycles of operation  	-30°C/80□ 10 cycles	—
Vibration Test	Endurance test applying the vibration during transportation and using.	Total fixed amplitude : 1.5mm Vibration Frequency : 10~55Hz One cycle 60 seconds to 3 directions of X,Y,Z for Each 15 minutes	<b>3</b>
Static Electricity Test	Endurance test applying the electric stress to the terminal.	VS=±600V(contact),± 800v(air), RS=330Ω CS=150pF 10 times	—

Note1: No dew condensation to be observed.

Note2: The function test shall be conducted after 4 hours storage at the normal Temperature and humidity after remove from the test chamber.

Note3: The packing have to including into the vibration testing.

### 10.Touch Panel Information

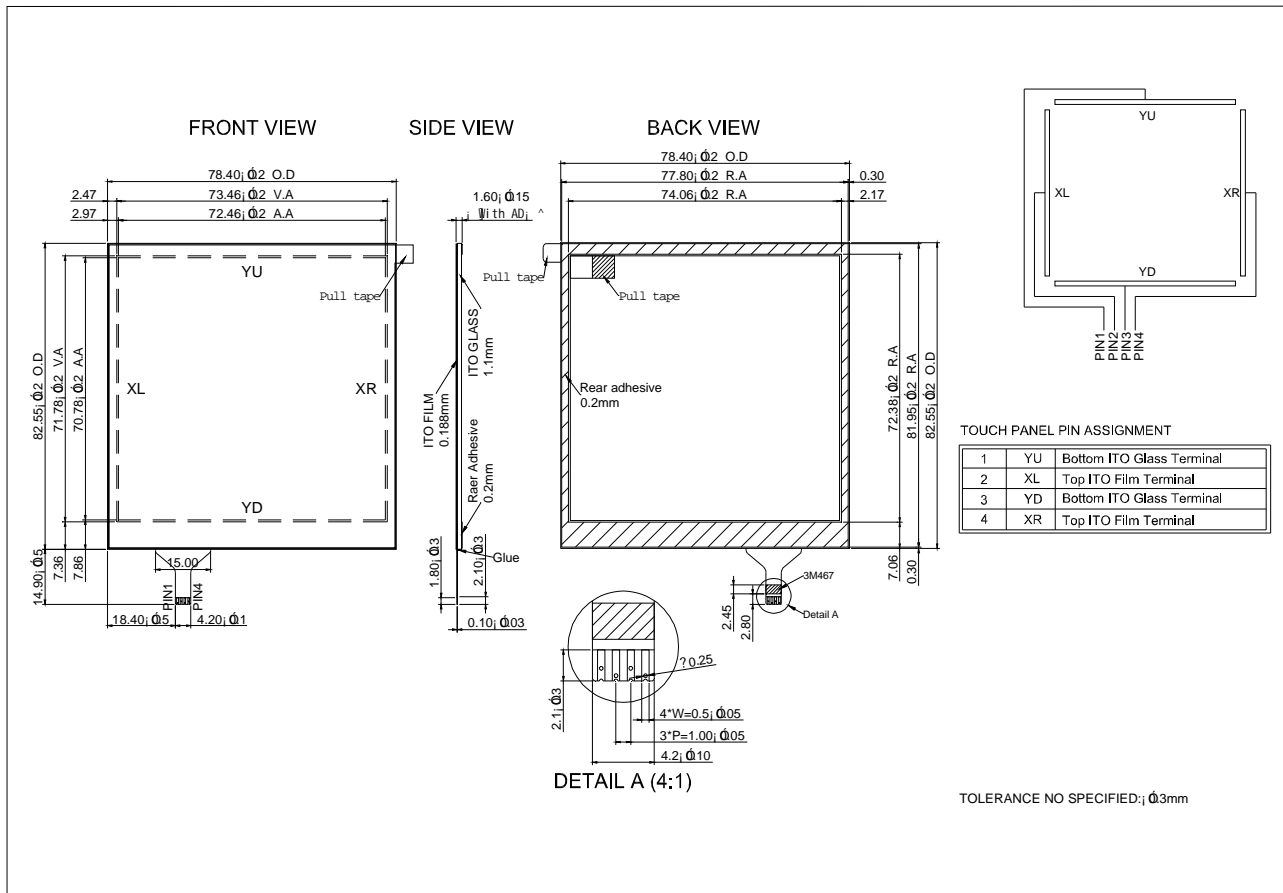

#### 10.1. Resistance Touch Panel General Specifications

Item	Description
Driving Condition	DC 5V Max
Operating Force	<100g
Linearity	≤1.5%
Insulating Resistance	≥10MΩ(DC 25V)
Light Transparence	70%
Structure Type	ITO Film+ITO Glass(1.1mm)
Surface Hardness	≥3H
Pen Hitting Durability (with the silicon rubber)	> 1000,000 times
X Axis Resistance	200~600Ω
Y Axis Resistance	200~600Ω

## 11.Initial Code For Reference

External system porch setting:125>VBP $\geq$ 17, VFP $\geq$ 20

Two data lanes / maximum speed 550Mbps

Void ST7701S\_PanellInitialCode(void)

```
{
//-----Reset Sequence-----//
LCD_Nreset(1);
Delaysms (1); //Delay 1ms
LCD_Nreset(0);
Delaysms (1); //Delay 1ms
LCD_Nreset(1);
Delaysms (120); //Delay 120ms
WriteComm (0x11);
Delaysms (120); //Delay 120ms

//-----Initial setting-----//
WriteComm (0xFF);
WriteData (0x77);
WriteData (0x01);
WriteData (0x00);
WriteData (0x00);
WriteData (0x10);

WriteComm (0xC0);
WriteData (0x3B);
WriteData (0x00);

WriteComm (0xC1);
WriteData (0x0D);
WriteData (0x02);

WriteComm (0xC2);
WriteData (0x30);
WriteData (0x05);

WriteComm (0xCC);
WriteData (0x10);
```

**WriteComm (0xB0);**

**WriteData (0x01);**

**WriteData (0x08);**

**WriteData (0x10);**

**WriteData (0x0C);**

**WriteData (0x10);**

**WriteData (0x06);**

**WriteData (0x07);**

**WriteData (0x08);**

**WriteData (0x07);**

**WriteData (0x22);**

**WriteData (0x04);**

**WriteData (0x14);**

**WriteData (0x12);**

**WriteData (0xB3);**

**WriteData (0x3A);**

**WriteData (0x1F);**

**WriteComm (0xB1);**

**WriteData (0x13);**

**WriteData (0x19);**

**WriteData (0x1F);**

**WriteData (0x0F);**

**WriteData (0x14);**

**WriteData (0x07);**

**WriteData (0x07);**

**WriteData (0x08);**

**WriteData (0x07);**

**WriteData (0x22);**

**WriteData (0x02);**

**WriteData (0x0F);**

**WriteData (0x0F);**

**WriteData (0xA3);**

**WriteData (0x28);**

**WriteData (0x0D);**

**WriteComm (0xFF);**

**WriteData (0x77);**

**WriteData (0x01);**

**WriteData (0x00);**

**WriteData (0x00);**

**WriteData (0x11);**

**WriteComm (0xB0);**

**WriteData (0x60);**

**WriteComm (0xB1);**

**WriteData (0x2D);**

**WriteComm (0xB2);**

**WriteData (0x07);**

**WriteComm (0xB3);**

**WriteData (0x80);**

**WriteComm (0xB5);**

**WriteData (0x49);**

**WriteComm (0xB7);**

**WriteData (0x85);**

**WriteComm (0xB8);**

**WriteData (0x21);**

**WriteComm (0xC1);**

**WriteData (0x78);**

**WriteComm (0xC2);**

**WriteData (0x78);**

**Delays (100);**

**WriteComm (0xE0);**

**WriteData (0x00);**

**WriteData (0x1B);**

**WriteData (0x02);**

**WriteComm (0xE1);**

**WriteData (0x08);**

**WriteData (0xA0);**

**WriteData (0x00);**  
**WriteData (0x00);**  
**WriteData (0x07);**  
**WriteData (0xA0);**  
**WriteData (0x00);**  
**WriteData (0x00);**  
**WriteData (0x00);**  
**WriteData (0x44);**  
**WriteData (0x44);**

**WriteComm (0xE2);**  
**WriteData (0x11);**  
**WriteData (0x11);**  
**WriteData (0x44);**  
**WriteData (0x44);**  
**WriteData (0xED);**  
**WriteData (0xA0);**  
**WriteData (0x00);**  
**WriteData (0x00);**  
**WriteData (0xEC);**  
**WriteData (0xA0);**  
**WriteData (0x00);**  
**WriteData (0x00);**

**WriteComm (0xE3);**  
**WriteData (0x00);**  
**WriteData (0x00);**  
**WriteData (0x11);**  
**WriteData (0x11);**

**WriteComm (0xE4);**  
**WriteData (0x44);**  
**WriteData (0x44);**

**WriteComm (0xE5);**  
**WriteData (0x0A);**  
**WriteData (0xE9);**  
**WriteData (0xD8);**  
**WriteData (0xA0);**  
**WriteData (0x0C);**

**WriteData (0xEB);**  
**WriteData (0xD8);**  
**WriteData (0xA0);**  
**WriteData (0x0E);**  
**WriteData (0xED);**  
**WriteData (0xD8);**  
**WriteData (0xA0);**  
**WriteData (0x10);**  
**WriteData (0xEF);**  
**WriteData (0xD8);**  
**WriteData (0xA0);**

**WriteComm (0xE6);**  
**WriteData (0x00);**  
**WriteData (0x00);**  
**WriteData (0x11);**  
**WriteData (0x11);**

**WriteComm (0xE7);**  
**WriteData (0x44);**  
**WriteData (0x44);**

**WriteComm (0xE8);**  
**WriteData (0x09);**  
**WriteData (0xE8);**  
**WriteData (0xD8);**  
**WriteData (0xA0);**  
**WriteData (0x0B);**  
**WriteData (0xEA);**  
**WriteData (0xD8);**  
**WriteData (0xA0);**  
**WriteData (0x0D);**  
**WriteData (0xEC);**  
**WriteData (0xD8);**  
**WriteData (0xA0);**  
**WriteData (0x0F);**  
**WriteData (0xEE);**  
**WriteData (0xD8);**  
**WriteData (0xA0);**

**WriteComm (0xEB);**  
**WriteData (0x02);**  
**WriteData (0x00);**  
**WriteData (0xE4);**  
**WriteData (0xE4);**  
**WriteData (0x88);**  
**WriteData (0x00);**  
**WriteData (0x40);**

**WriteComm (0xEC);**  
**WriteData (0x3C);**  
**WriteData (0x00);**

**WriteComm (0xED);**  
**WriteData (0xAB);**  
**WriteData (0x89);**  
**WriteData (0x76);**  
**WriteData (0x54);**  
**WriteData (0x02);**  
**WriteData (0xFF);**  
**WriteData (0xFF);**  
**WriteData (0xFF);**  
**WriteData (0xFF);**  
**WriteData (0xFF);**  
**WriteData (0x20);**  
**WriteData (0x45);**  
**WriteData (0x67);**  
**WriteData (0x98);**  
**WriteData (0xBA);**

**WriteComm (0x36);**  
**WriteData (0x08);**

**WriteComm (0x29);**

**WriteComm (0x3A);**  
**WriteData (0x77);**

**}**