

DISPLAY Elektronik GmbH

DATA SHEET

BACKLIGHT

DE LP-504-RGB

Product Specification

Version: 0

26.09.2016

GENERAL SPECIFICATION

MODEL NO. :

DE LP-504-RGB

CUSTOMER P/N

Version No.	Change Description	Date
0	Original Version	26.09.2016

PREPARED BY: ZX

DATE: 26.09.2016

APPROVED BY: MH

DATE: 26.09.2016

CONTENTS

1. FEATURES2

2. EXTERNAL DIMENSION (UNIT: MM).....2

3. ELECTRICAL/OPTICAL SPECIFICATIONS.....3

4. ACCEPT QUALITY LEVEL (AQL). FEHLER! TEXTMARKE NICHT DEFINIERT.

5. RELIABILITY TEST..... FEHLER! TEXTMARKE NICHT DEFINIERT.

1. FEATURES

Backlight Color: RGB

RoHS: Conformed

2. EXTERNAL DIMENSION (unit: mm)

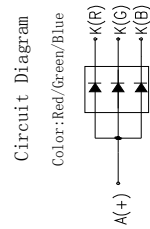
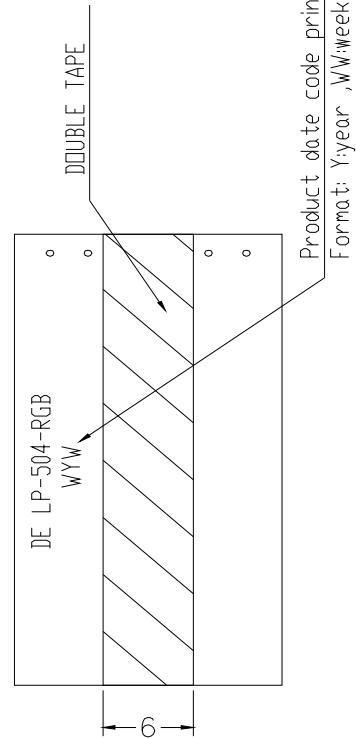
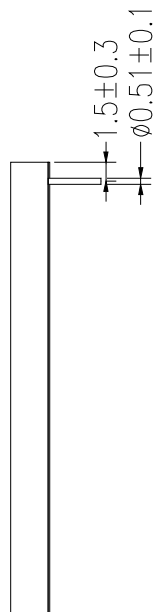
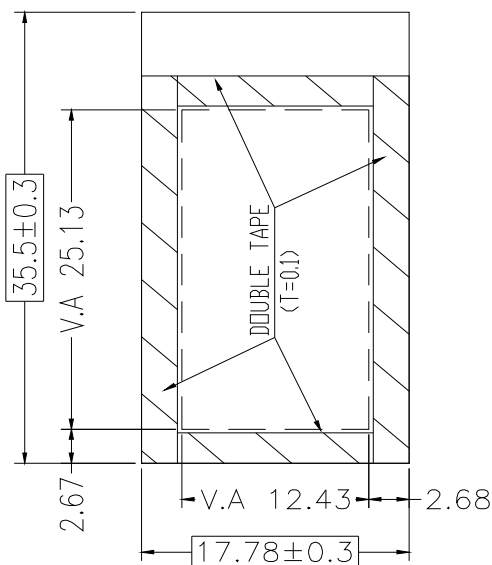
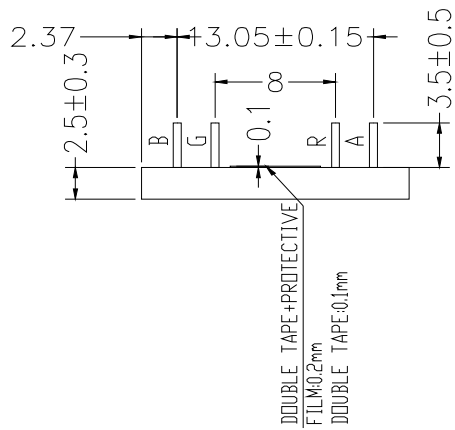

INTERNAL CIRCUIT DIAGRAM

Remarks:

1. Unmarked tolerance is ±0.3
2. All materials comply with Rohs
3. ...:critical dimension.
4. Operation temperature: -20°C to +70°C
Storage temperature: -40°C to +90°C

3. ELECTRICAL/OPTICAL SPECIFICATIONS

ELECTRICAL–OPTICAL CHARACTERISTICS

Ta=25°C. Unless specified, The Ambient temperature Ta=25°C

Item	Symbol	RED			GREEN			BLUE			Unit	Condition
		MIN.	TYP.	MAX.	MIN.	TYP.	MAX.	MIN.	TYP.	MAX.		
Forward Current	Vf	1.9	2.1	2.5	2.8	3.0	3.4	2.9	3.1	3.5	mA	If=20mA
Dominant Wave Length	λ D	620	625	630	515	520	525	465	470	475	nm	If=20mA
Color Chromaticity	X	—	—	—	—	—	—	—	—	—		
	Y	—	—	—	—	—	—	—	—	—		
Uniformity	Avg	65			65			65			%	
Luminance	Lv	200	400		500	600		100	200		cd/m ²	
Reverse Current (Per LED)	Ir			10			10			10	μ A	Vr= 5.0 V
Lifetime		50000(brightness reduce half)										

4. ACCEPT QUALITY LEVEL (AQL).

4.1. AQL standard value: Critical defect =0, Major defect=0.65; Minor defect =2.5.

4.2. Inspection Plan: ANSI Z-1.4, Normal Inspection Level II, Single Sampling Plan.

5. RELIABILITY TEST

Test Item	Test Condition
High Temperature Storage	+90°C x 96h
Low temperature Storage	-40°C x 96h
High Temperature Operation	+70°C x 96h
Low Temperature Operation	-20°C x 96h
High Temperature, High Humidity	60°C x 90%RH x 4 Weeks
Thermal Shock	-20°C x 30min → 25°C x 10s → +70°C x 30min x 5 Cycles
Vibration Test	Frequency x Swing x Time 40Hz x 4mm x 4h
Drop Test	Height x Number of drop 1.0m x 6 drops